

Using the HOBO® Light Pipe (UX90-LIGHT-PIPE-1) with the Light On/Off (UX90-002x) and Occupancy/Light (UX90-005x/-006x) Loggers

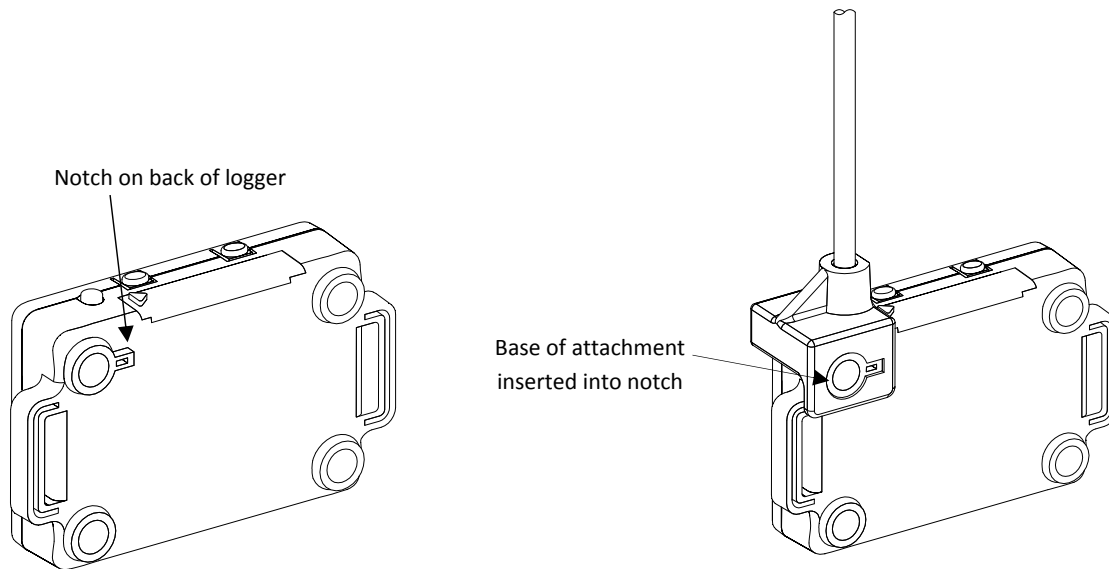

An optional fiber optic attachment or light pipe (UX90-LIGHT-PIPE-1) is available for the HOBO Light On/Off (UX90-002x) and Occupancy/Light (UX90-005x/-006x) loggers. This attachment connects to the back of the logger. To install it, locate the notch in the upper left corner next to the mounting magnet. Insert the black base of the attachment into the notch so that the base clips onto the corner of the logger as shown below.



Follow these guidelines when using a light pipe:

- Make sure the end of the light pipe is as close to the light source as possible.
- Avoid 90-degree bends. The light pipe is flexible and can be bent to gain access to hard-to-reach areas, but should not have any sharp, 90-degree bends.
- Maximize the signal strength on the logger LCD screen by adjusting the light pipe while looking at the signal bars (see *Calibrating the Light Sensor* below for more details).
- Be sure to secure the light pipe after the signal has been optimized.
- Do not support the logger by the light pipe.
- Be sure that the pipe is seated all the way into the bracket before deployment.

Calibrating the Light Sensor

Each time you place the logger in a new lighted environment, you should calibrate it to the light level that you will be monitoring. This ensures the logger is accurately determining when the light changes between ON and OFF states. There are two calibration methods available: auto-calibration (button calibration) or preset calibration via HOBOWare®.

Auto-calibration is used to calibrate the ON and OFF threshold of the logger to achieve reliable readings in an environment where ambient conditions are unknown prior to deployment or where logger light levels are variable. In the auto-calibration process, the light is measured via a built-in analog-to-digital converter and the resulting value is used to generate a calibration threshold. **Note:** Auto-calibration (button calibration) must be done at the location where the logger will be deployed.

Preset values are used when light levels are known in advance and deployment speed is critical.

The logger has a built-in hysteresis level of approximately $\pm 12.5\%$ to prevent the sensor from toggling between ON and OFF when the light level is near the calibration threshold. This plot shows how the logger handles hysteresis. The logger interprets the signal, or light, as ON until it drops below the lower level of the calibration threshold. Once it switches to off, the signal will not switch back to ON until it bypasses the upper limit of the calibration level.

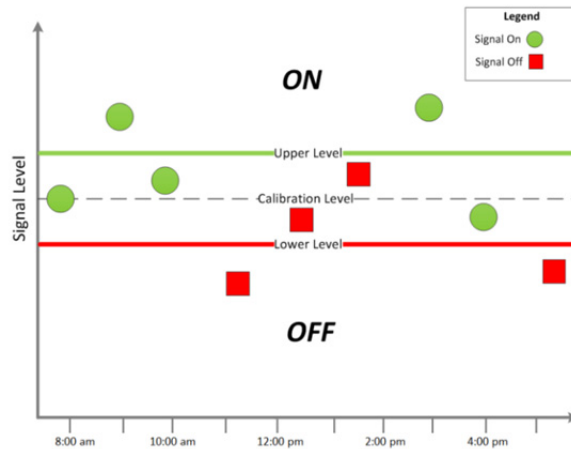

When auto-calibrating from the logger (button calibrating):

1. After launching, deploy the logger near the light source to be monitored and turn the light source on.
2. Press the Calibrate button for 1 second. The LCD screen will display the signal strength of the light. The signal strength should ideally be at least 3 bars. Orient the logger as necessary to increase the signal strength.
3. Press the Calibrate button for 3 seconds while “HOLD” appears on the LCD screen. Move your hand away from the logger to prevent shadowing. The logger will count down to the auto-calibration and then display either “PASS” or “FAIL” after calibration is complete.
4. If the auto-calibration fails, point the sensor directly at the light source and then repeat these steps.

If you cannot manipulate the light source, you can set the calibration level in HOBOWare. To do this:

1. From the Device menu in HOBOWare, click Launch.
2. Click the Advanced button in the Launch Logger window.
3. The lower the light level, the higher the sensitivity needs to be to record changes between ON and OFF conditions. Therefore:
 - For rooms with low light levels, such as residential environments, select “Set to maximum sensitivity,” which has a threshold set to approximately 100 lux.
 - For rooms with high light levels, such as retail environments, select “Set to minimum sensitivity,” which has a threshold set to approximately 500 lux.

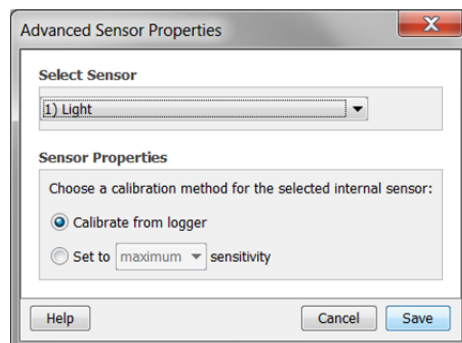

Note: The sensor is sensitive to lights that emit high amounts of infrared radiation like incandescent and halogen bulbs. It is best to use auto-calibration when possible when monitoring on/off conditions for lights with high infrared radiation.

4. Click Save. Note that the selections will not take effect in the logger until you launch it.