

ThermoView TV30 Series

Thermal Imager Camera



1

2

TV30 Camera Quick Start Safety Sheet

3

-10 – 50°C
(14 – 122°F)

IP67

4

5

5 Spot Size Calculator App

6 Spot Size Calculator App

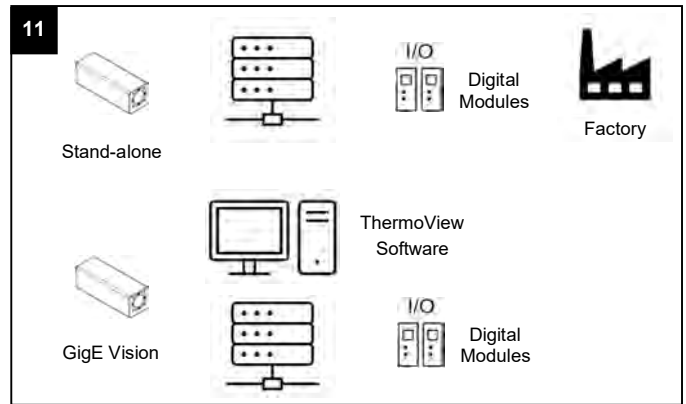
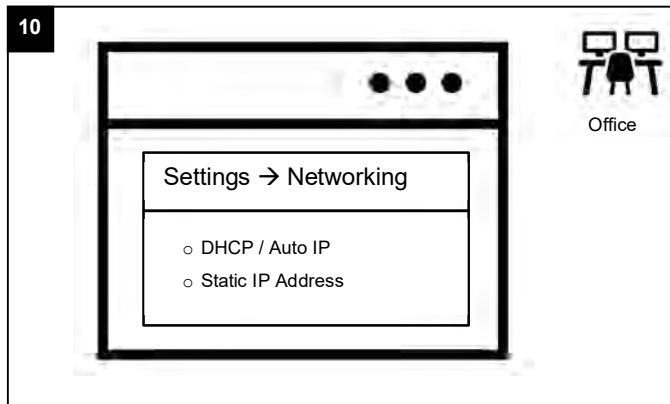
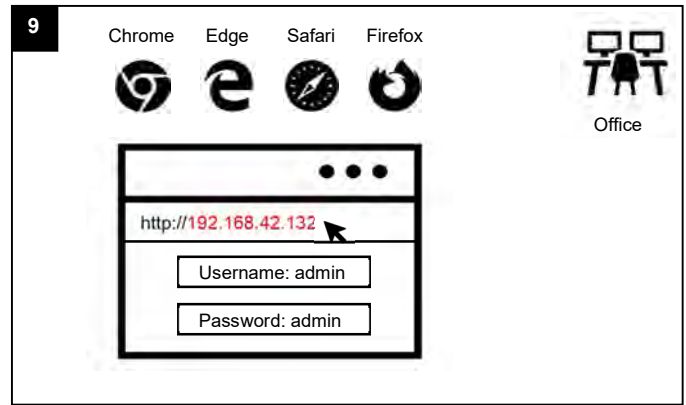
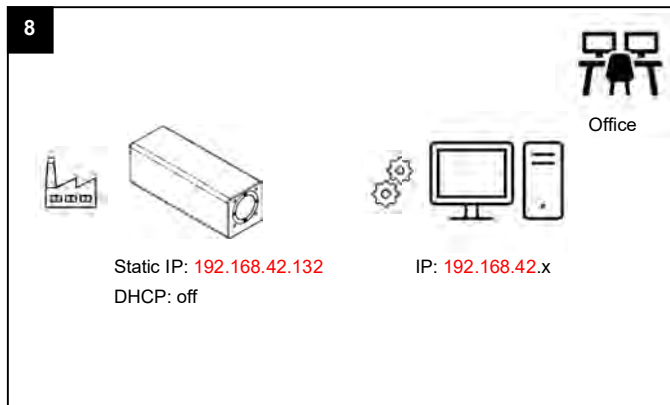
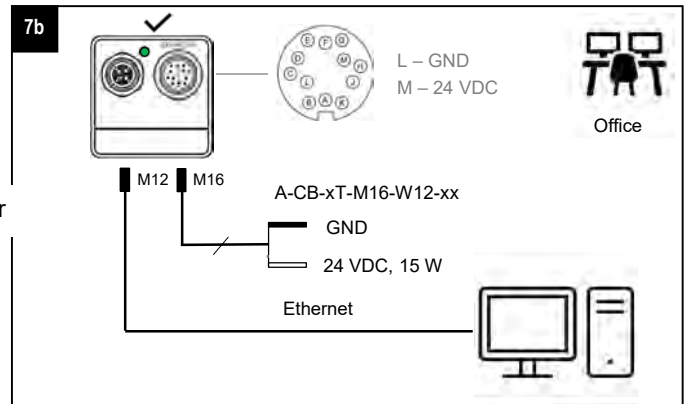
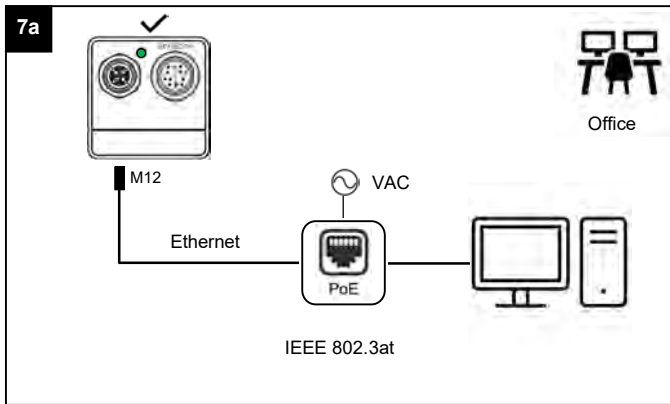

TV3	X	-	XX	-	X	-	X	-	XX
Series	Model		Type		Temp Range		Lens		Frame Rate
	3 - 320x240 pixel 6 - 640x480 pixel		SA - Stand alone		L -10 to 1300°C (14 to 2372°F)		S - Standard W - Wide angle T - Tele		60 - 60 Hz 09 - 9 Hz

Fluke Process Instruments

Worldwide Service
Fluke Process Instruments offers services, including repair and calibration.
For more information, contact your local office.



© 2023 Fluke Process Instruments
Specifications subject to change without notice. 05/2023 - Rev. 1.0, 5340926