

SHARK® 100S/200S

Multifunction WiFi Electric Submeters



Advanced Submetering

- ANSI C12.20 0.2 Accuracy Class Energy Measurements
- Revenue Certifiable Test Pulse with KYZ Output
- **New** Simultaneous Ethernet and WiFi or RS485 Communication
- WPA/WPA2/WPA2-Enterprise/WPS, Trust & Go 608 Chip WiFi Security
- Modbus ASCII/RTU/TCP and DNP3 Protocols
- Extensive Data Logging (Shark® 200S Submeter)
- Bright Red LED Display with Three .56" Lines

Shark® 100S
Multifunction WiFi
Electric Submeter



Shark® 200S
Data Logging WiFi
Electric Submeter



Introduction

The Shark® 100S/200S submeters are revenue certified 0.2% energy accuracy meters. They provide standard Modbus communication over RS485 serial or simultaneous Ethernet and WiFi. WiFi communication is protected with WPA2 and other advanced WiFi encryption technology.



Revenue Certified Metering with Modbus Ethernet and WiFi Communication

Additional features include:

- Direct interface with most building management systems.
- Ideal for bill generation department cost allocation.
- Harmonics measurement (Shark® 100S submeter).
- Transformer Line Loss and CT/PT compensation (Shark® 200S submeter).

Applications

- University energy management.
- Industrial cost allocation.
- Commercial building tenant billing.
- Government facility energy management.
- Shopping mall tenant billing.
- Military energy management.
- Airport tenant billing.

Superior Design

- Standard 5 A or 1 A CTs.
- Submeters surface mount to any wall.
- Bright red LED display with three .56" lines for easy meter reading.
- Inner cover to ensure safety when installing.
- Optional remote antenna available (model number ANT18769).
- Voltage up to 721 V line-to-line.
- Power supply up to 400 V AC.
- Simultaneous Ethernet and WiFi module.

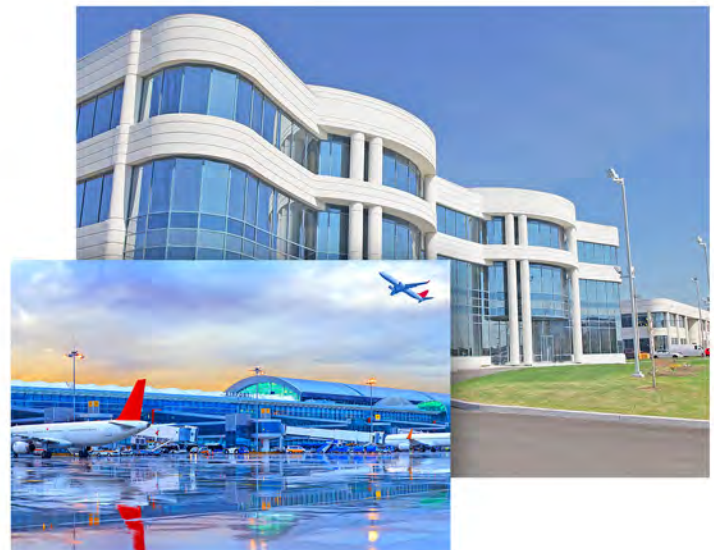
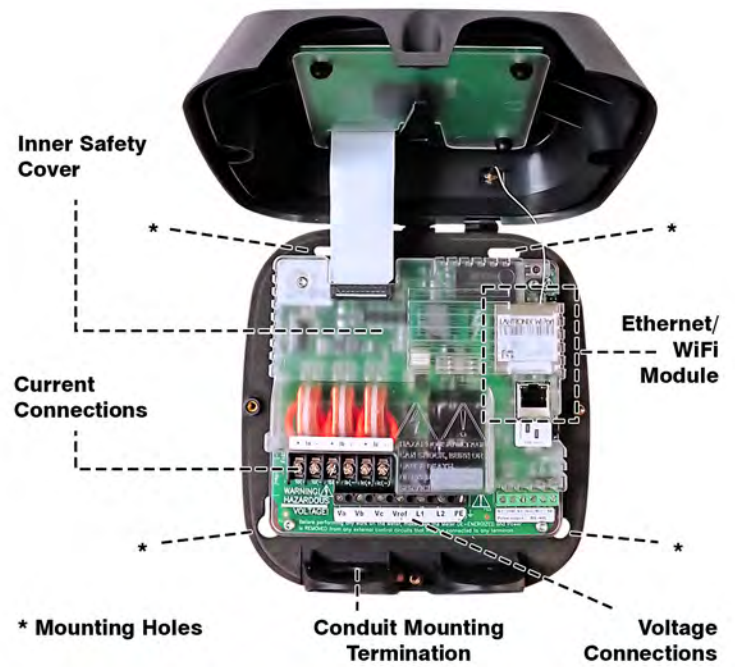

Shark® Series Submeter Revenue Certified Metering Accuracy

The Shark® 100S/200S meters provide ANSI C12.20 and IEC 62053-22 0.2% Class energy metering accuracy. Refer to the following accuracy chart.

Measured Values	Accuracy %
Voltage L-N	0.1% of Reading
Voltage L-L	0.1% of Reading
Current	0.1% of Reading
+/- Watts	0.2% of Reading
+/-Wh	0.2% of Reading
+/-VARs	0.2% of Reading
+/-VARh	0.2% of Reading
VA	0.2% of Reading
VAh	0.2% of Reading
PF	0.2% of Reading
Frequency	0.03 Hz (100S) / 0.007 Hz (200S)
THD (Shark® 100S only)	5.0 %
% Load Bar	+/- 1 Segment

Traceable Watt-Hour Test Pulse for Accuracy Certification

In order to certify a submeter for revenue metering, power providers and utilities need to verify the meter's stated accuracy. They use field test standards to ensure that the meter's energy measurements are correct. As traceable revenue meters, the Shark® 100S/200S submeters contain a utility grade test pulse used for this accuracy verification.

Multiple Communication Paths

Standard Modbus RS485 Communication

Use the submeters' standard RS485 port to connect to any serial RS485 bus using the Modbus interface. This lets the unit communicate easily with most building automation or other software systems.

Standard IrDA Port

Use an IrDA-equipped laptop PC to program and read the Shark® 100S/200S submeter via its standard IrDA port.

Simultaneous Ethernet and Encrypted WiFi Communication

The Shark® 100S/200S submeters have optional Ethernet/WiFi communication. The option communicates Modbus TCP/IP over multiple, simultaneous RJ45 wired and wireless Ethernet. Choose whichever method meets the application needs and easily configure the connection using the embedded web server.

Benefits include:

- Up to ten communication sockets for both RJ45 Ethernet and WiFi.
- Data is protected over WiFi with WPA/WPA2/WPA2-Enterprise/WPS, and Trust & Go 608 Chip WiFi Security.

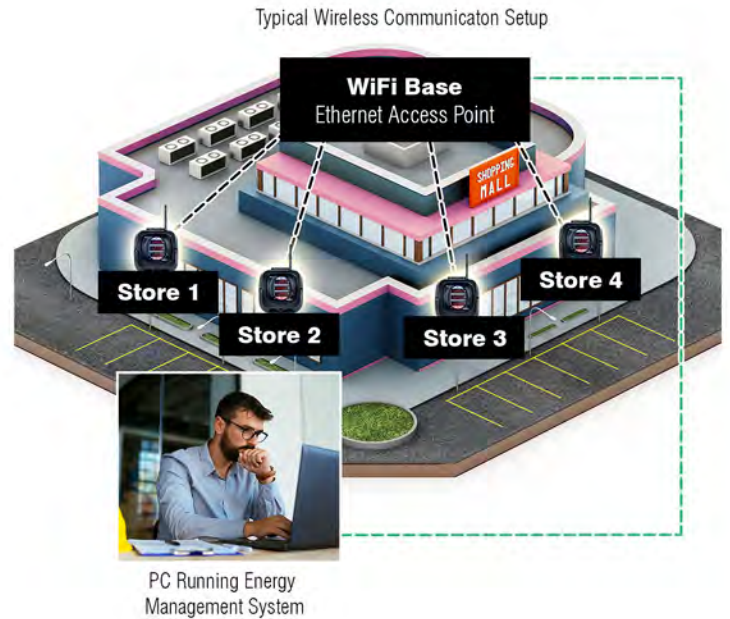

Encrypted WiFi Communication Eliminates Cable Runs

KYZ Pulse

The unit provides a KYZ output which pulses proportional to the amount of energy consumed. Use this output for pulse counting applications or for building management systems where serial or Ethernet protocol is not available.



Shark® 200S Advanced Logging Features

The Shark® 200S submeter provides extensive data logging. It has three historical logs, a limits/alarm log, and a system events log. The unit has a real time clock that timestamps all data in the instrument when log events are created.

Historical Logs

Each of the three historical logs can be programmed with unique parameters consisting of any measured reading. Up to 64 parameters can be recorded per log.

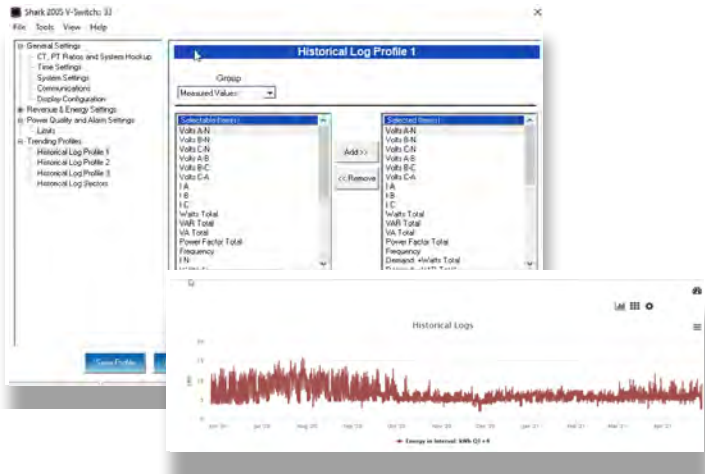

Limits/Alarm Log

This log provides magnitude, duration, timestamp, and alarm value for up to 2048 events.

Limit ID	Item	Value	Status	Limit 1	Limit 2	Setting	Alarm	Hysteresis	Setting	Alarm	Hysteresis
1	Volts A-N	15.148	In	In		Above 15.840k	15.840k	Below 12.960k	12.960k		
2	Volts B-N	15.148	In	In		Above 15.840k	15.840k	Below 12.960k	12.960k		
3	Volts C-N	15.148	In	In		Above 15.840k	15.840k	Below 12.960k	12.960k		
4	Watts Total	428.23	Off	In	In	Above 172.800M	129.600M	Below 0.000	0.000		
5	Frequency	60.01	Off	In	In	Above 51.000	51.000	Below 49.000	49.000		

System Events (Anti-tampering) Log

To protect critical billing information, the meter records and logs the following with a timestamp:

- Demand/energy/log resets.
- Password requests.
- System startup.
- Log reads.
- Changes to meter's programmable settings.

EnergyPQA.com® Cloud-based Energy Management System

The EnergyPQA.com® system provides energy analytics enterprise wide with AI-based predictions and deep insights into power quality. Its energy and demand dashboards and usage charts make it easy to compare energy consumption, power quality, and usage patterns in all metered areas of a building. The Shark® 100S/200S units integrate seamlessly with the EnergyPQA.com® system, providing the following capabilities:

- Increase energy usage efficiency by analyzing load disaggregation and usage comparisons.
- Perform proper cost allocation and submetering by billing for actual energy usage versus square footage estimations.
- Reduce costs with predicted peak demand email alerts into the future.
- Identify poorly performing buildings by comparing energy usage across facilities.
- Generate automated reports with detailed energy usage for metered points, facilities, and enterprise as a whole.
- Determine impact on the environment and assess the success of sustainability initiatives by monitoring total and per location carbon footprint.

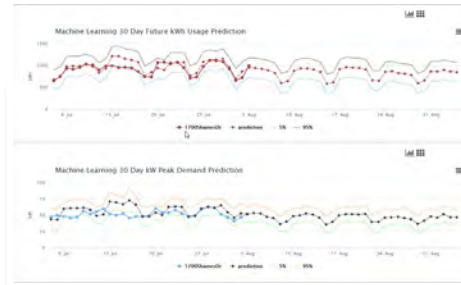

View 30 Day Predicted Energy Usage and Demand

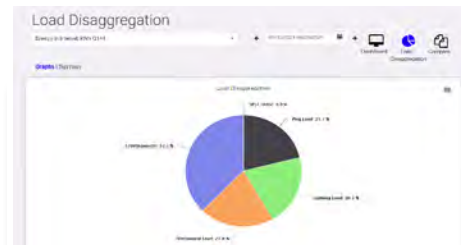

Perform Load Disaggregation for Usage Comparison



View Degree Days for Selected Date Range

Energy Usage Analysis and Billing

Use EnergyReporterPQA™ software with the Shark® 100S/200S submeters to generate accurate customer billing. Billing for actual usage promotes energy conservation from tenants with resulting energy cost savings of up to 18%. Features of the EnergyReporterPQA™ software include:

- Automatically import usage data from the submeters.
- Set up multiple rate structures with fees, taxes, and surcharges.
- Customize and automatically generate bills and invoices.
- Track energy use by customer/location/meter.
- Set up holidays, peak and off-peak hours.
- Generate executive summary usage reports.

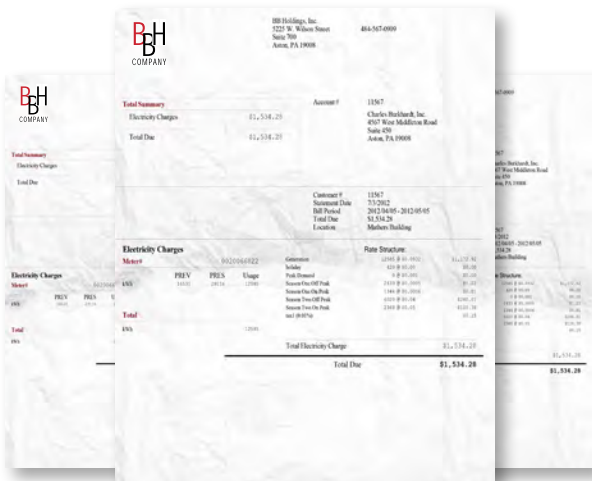

Generate Bills and Invoices

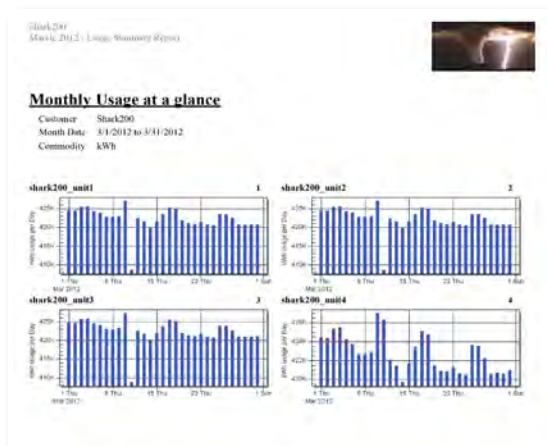

Executive Usage Summary Reports

Advanced Features

Shark® 100S Submeter

The Shark® 100S submeter has a V-Switch™ key option that adds THD and Limits to its multifunction metering capability. EIG's exclusive V-Switch™ technology enables firmware upgrades in the field without removing the meter from installation. The Shark® 100S submeter can be ordered with THD and Limits or those features can be added later through a V-Switch™ upgrade.

Shark® 200S Submeter

The Shark® 200S submeter has data logging memory and Limits as a standard offering. The 200S also has Transformer Line Loss and CT/PT compensation revenue metering features.

Available V-Switch™ Keys

- V3 (100S only) – Volts, A, kW, kVAR, PF, kVA, Freq, kWh, kVAh, kVARh.
- V4 (100S only) – Volts, A, kW, kVAR, PF, kVA, Freq, kWh, kVAh, kVARh, THD monitoring, and limit-exceeded alarms.
- V33 (200S only)- Volts, A, kW, kVAR, PF, kVA, Freq, kWh, kVAh, kVARh, 2 MB data logging memory, and limit-exceeded alarms.

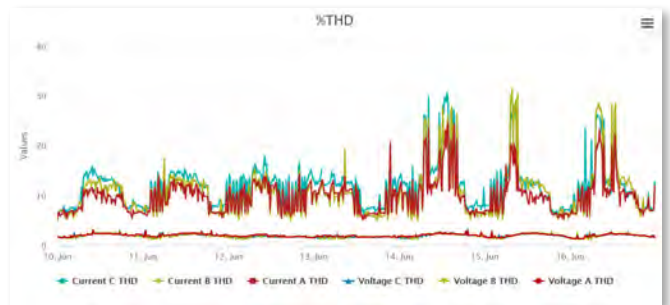

Shark® 100S Submeter THD Screen

Limit ID	Item	Value	Status	Limit 1	Limit 2	Setting	Point 1	Hysteresis	Setting	Point 2	Hysteresis
1	Volts A-N	10.70kV	In	In	Above 15.840kV	15.840kV	Below 12.960kV	12.960kV			
2	Volts B-N	15.700kV	In	In	Above 15.840kV	15.840kV	Below 12.960kV	12.960kV			
3	Volts C-N	15.700kV	In	In	Above 15.840kV	15.840kV	Below 12.960kV	12.960kV			
4	Watts Total	44818.12kW	In	In	Above 172.800M	129.600M	Below 0.000	0.000			
5	Frequency	59.95	Out	In	Above 51.000	51.000	Below 49.000	49.000			

Shark® 100/200S Submeter Alarm Limits Polling Screen

Dimensional Drawings

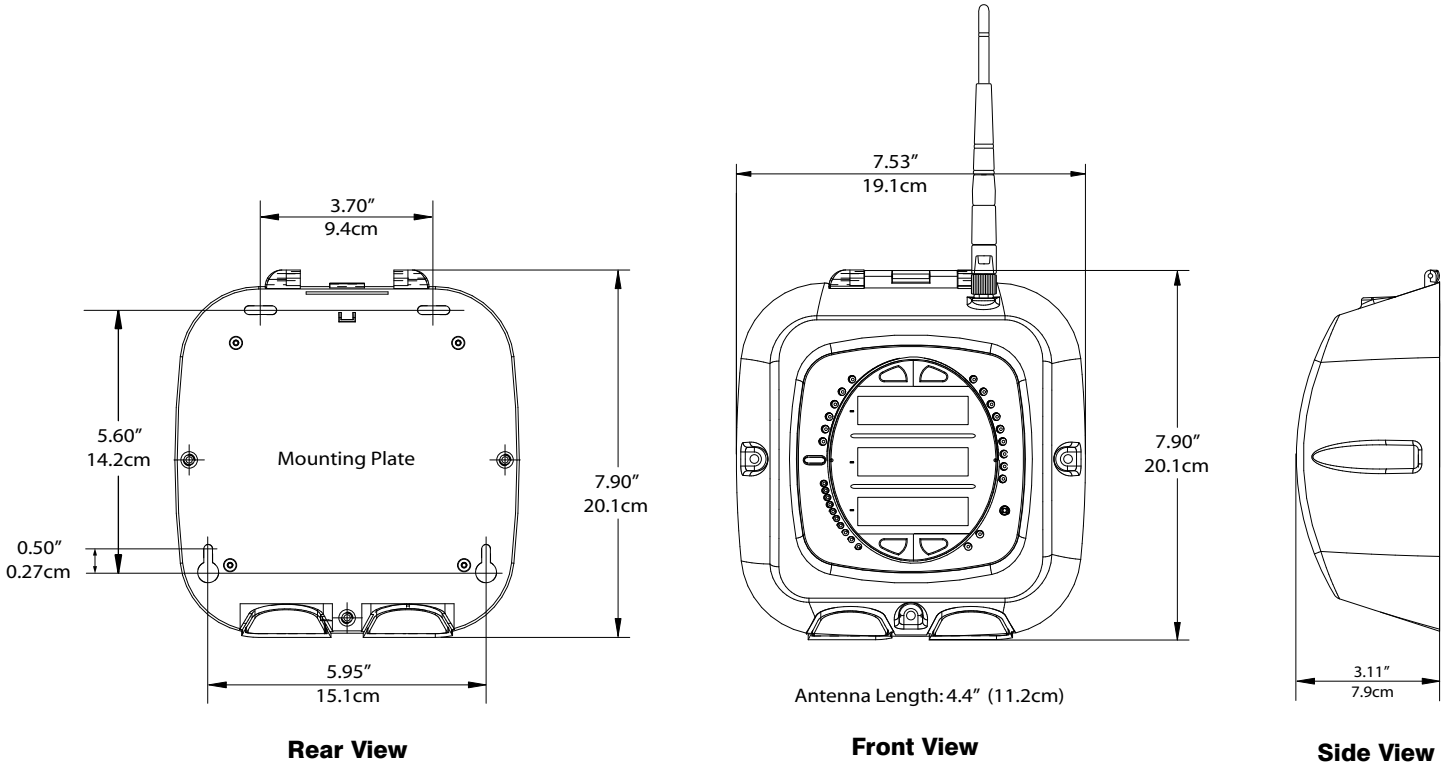

Installation

Open for Installation

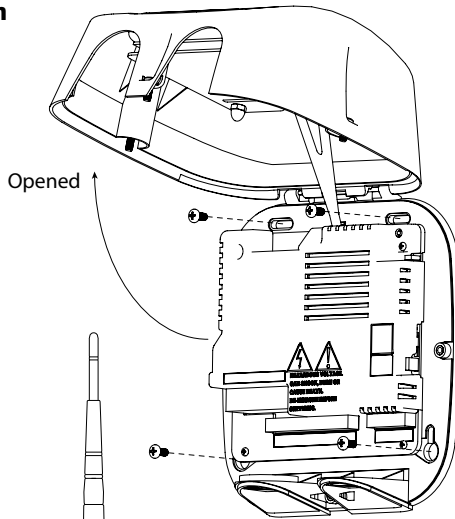

Close for Operation

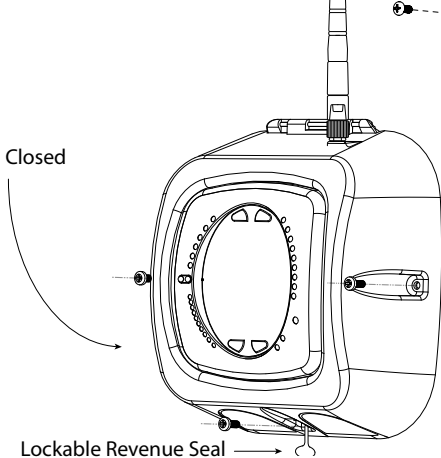

Optional Remote Antenna

Use EIG's ANT18769 remote antenna kit to extend WiFi communication for the Shark[®] submeters. The kit contains the antenna, magnetic base, and 2000mm coaxial cable. Connect the antenna to the submeter's WiFi jack using the magnetic base. The remote antenna can be used with any wireless router to extend the WiFi network.



ANT18769 Remote Antenna Kit

Wiring Diagrams

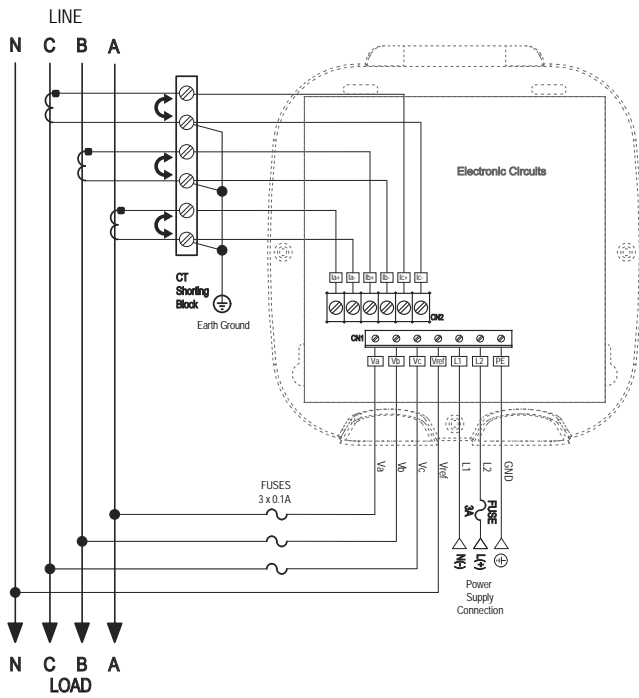

**3 Phase 4 Wire WYE
Direct**

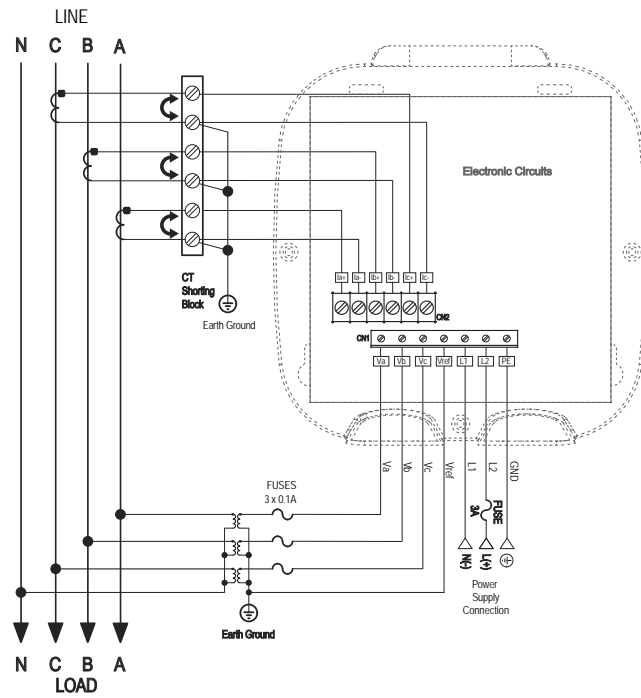

**3 Phase 4 Wire WYE
with PTs**

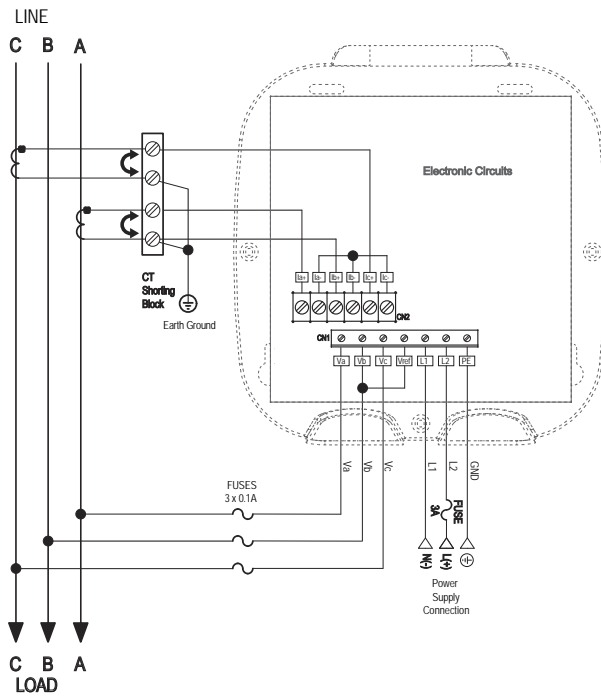

**3 Phase 3 Wire Delta
Direct**

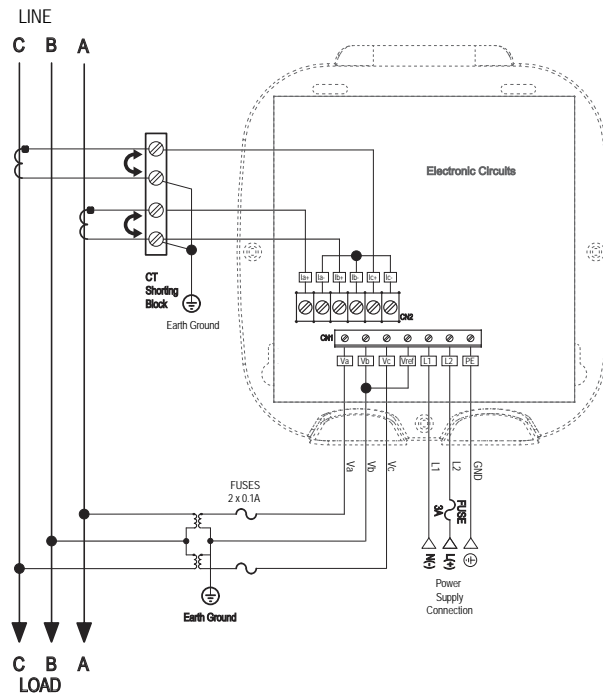

**3 Phase 3 Wire Delta
with PTs**

Specifications

Voltage Inputs:

- Absolute Range: (20-416) Volts Line to Neutral (Shark® 100S meter), (20-576) Volts Line to Neutral (Shark® 200S meter)
- (0-721) Volts Line to Line
- Universal Voltage Input
- Input Withstand Capability: Meets IEEE C37.90.1 (Surge Withstand Capability)
- Programmable Voltage Range to Any PT ratio
- Supports: 3 Element WYE, 2.5 Element WYE, 2 Element Delta, 4 Wire Delta Systems
- Burden: 0.36 VA/Phase Max at 600 V, 0.014 VA/Phase at 120 V

Current Inputs:

- Class 10: 5 A Nominal CT Secondary, 10 A Max
- Class 2: 1 A Nominal CT Secondary, 2 A Max
- Programmable Current to Any CT Ratio
- Burden 0.005 VA/Phase Max at 11 A
- Pickup Current: 0.1% of Nominal
- Current Surge Withstand: 100 A/10 Seconds at 23 °C

Isolation:

- All Inputs and Outputs are Galvanically Isolated to 2500 V AC

Environmental Rating:

- Storage: (-20 to +70) °C
- Operating: (-20 to +70) °C
- Humidity: to 95% RH (Non-Condensing)
- Protection: IP30 - Meter Front/Back

Sensing Method:

- True RMS
- Sampling at over 400 Samples/Cycle on all Channels of Measured Readings Simultaneously
- THD (% of Total Harmonic Distortion) - Shark® 100S meter only

Update Rate:

- Watts, VARs, and VA - Every 6 Cycles (e.g., 100 ms @ 60 Hz)
- All Other Parameters - Every 60 Cycles (e.g., 1s @ 60 Hz) (1 second for Current Only measurement, if reference voltage is not available)

Power Supply:

- (90 to 400) Volts AC @50/60 Hz or (100 to 370) Volts DC/16 VA Max

Communication Format:

- 2 Serial Com Ports (Back and Faceplate)
 - RS485 Port through Backplate
 - IrDA through Faceplate
 - Com Port Baud Rate: (1200 - 57600)

- Com Port Address: 1-247
- 8 Bit, Parity Setting: Odd, Even, None
- Modbus ASCII/RTU or DNP3 Protocols

Ethernet/WiFi:

- RJ45 10/100BaseT Ethernet and 802.11b WiFi
- Modbus TCP/IP Protocol
- Simultaneous Wired and Wireless Communication

Dimensions and Shipping:

- Weight: 4 lbs /1.81 kg
- (7.9H x 7.5W x 3.1D) in/ (20.1H x 19.1W x 7.9D) cm

Meter Accuracy:

- See Page 3

Compliance:

- ANSI C12.20 2010 Accuracy, 0.2 CL (100S)/ANSI C12.20 2015, 0.2 Accuracy Class and C12.1 (MET Labs Certified) (200S)*
- ANSI C62.41 (Burst) (200S)*
- FCC, Part 15, Subpart B, Class A (Radiated and Conducted Emissions) (200S)*
- IEC 62053-22 Accuracy, Class 0.2S*/KEMA Labs Certified (200S)*
- IEC 62052-23 Edition 1 Class 2
- CE (IEC 61000-6-2 & IEC 61000-6-4 & IEC 61326-1)*

- IEC 61000-4-2 (Electrostatic Discharge)*
 - IEC 61000-4-3 (Radiated EM Immunity)*
 - IEC 61000-4-4 (EFT)*
 - IEC 61000-4-5 (Surge Immunity)*
 - IEC 61000-4-6 (Conducted Immunity)*
 - IEC 61000-4-8 (Magnetic Immunity)*
 - IEC 61000-11 (Voltage Variations Immunity)*
 - IEC/CISPR 11 Class A (Conducted, Radiated Emissions)*
 - CISPR22, Class A, Fifth Ed. (200S)*
 - IEEE C37.90.1 (Surge Withstand)
 - IEEE C62.41 (Surge Immunity)
 - EU Directive 2011/65/ EU (RoHS 3 Directive)
 - REACH Compliant
 - (WiFi Module) ERM: Wideband transmission system operating in the 2.4GHz ISM band using wideband modulation techniques. V1.6.1 (WiFi Module) Information technology equipment-Safety-part 1: General requirements: 2001
 - Certified to UL 61010-1 and CSA C22.2 No. 61010-1, UL File: E250818*
- * Third party lab tested

Ordering Information - All fields must be filled in to create a valid part number.

Model	Frequency	Current Class	V-Switch™ Pack	Communication Format
Option Numbers:	-	-	-	-
Example:	Shark® 100S	60	V3	485
Shark® 100S Basic Submeter	50 50 Hz System	10 5 A Nominal CT Secondary	V3* Default with Energy Counters (Shark® 100S)	485 RS485
Shark® 200S Data Logging Submeter	60 60 Hz System	2 1 A Nominal CT Secondary	V4* Above with Harmonics and Limits (Shark® 100S)	WiFi WiFi and RJ45 Ethernet
* Shark® 100S meter only			V33** Multifunction Meter with 2 MB Data Logging Memory (Shark® 200S)	
** Shark® 200S meter only				

Accessories

Communication Converters

- CAB6490** USB to IrDA Adapter for Programming
- Unicom 2500** RS485 to RS232 Converter

Software Option Numbers

- COMPQA5P** CommunicatorPQA® Software, Single License
- ENERGYPQA-1Year** Cloud-based Energy Management Solution

Compliance Documents

- Calibration, Part#: CCal** This provides Certificate of Calibration with NIST traceable Test Data.

Remote Antenna

- ANT18769** Remote Antenna Kit

Current Transformers

- CT200K** 200/5 Ratio, 1.00" Window, 3 CTs
- CT400K** 400/5 Ratio, 1.25" Window, 3 CTs
- CT800K** 800/5 Ratio, 2.5" Window, 3 CTs
- CT2000K** 2000/5 Ratio, 3.00" Window, 3 CTs
- Frequency** 200/5 Ratio, 1.00" Window, 3 CTs

- Flexible Leads** UL 1015, 105 °C, CSA Approved, 24" Long, AWG#16

Note: Consult factory application engineer for additional transformer ratios, types, or window sizes.



Electro Industries/Gauque Tech™

1.800.561.8187

www.itm.com

information@itm.com