



The RS1 Solar Radiation Shield is recommended for temperature and RH measurement accuracy in locations exposed to direct or reflected solar radiation. It can be mounted on tripods, masts, or flat vertical surfaces. The Solar Radiation Shield works with HOBO® Pendant® loggers (UA-00x-xx), the HOBO Water Temp Pro v2 (U22-001), the TidbiT v2 (UTBI-001), HOBO Pro v2 Internal Temp/RH data logger (U23-00x), HOBO MX2300 series data loggers, and external temperature sensors for Onset data loggers.

Components

There are two types of components to the Solar Radiation Shield: the plates that join together to form the radiation shield and the installation hardware kit.

Radiation Shield Parts

- a. One Cover Plate
- b. One Support Plate
- c. One Flat Plate
- d. Three Closed Plates
- e. Three Open Plates

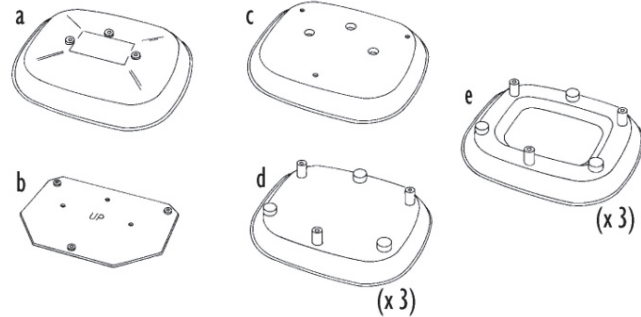

Installation Hardware Kit

- a. Two Clip Mounts
- b. Three 1/2 in. (13 mm) spacers
- c. Three 1 in. (25 mm) spacers
- d. Three Plastic Screw Retainers
- e. One Cable Tie
- f. One Wall Mount Bracket
- g. Two 1-1/2 in. U-bolts
- h. Four 1/4 in. Flat Washers
- i. Four 1/4 in. Hex Nuts
- j. One Cable Clamp
- k. Three # 8 x 5 in. (127 mm long) Threaded Rods with #8 Push Nuts
- l. Three #8 x 2-3/4 in. (70 mm long) Pan Head Screws
- m. Three #8 x 1-3/4 in. (44 mm long) Pan Head Screws
- n. Three #4 Flat Washers
- o. Four #4 x 1/2 in. (13 mm long) Pan Head Self-Threading Screws
- p. Twelve #8 Flat Washers
- q. Nine #8 Split Lock Washers
- r. Six #8 Hex Nuts
- s. Three 38 Wing Nuts

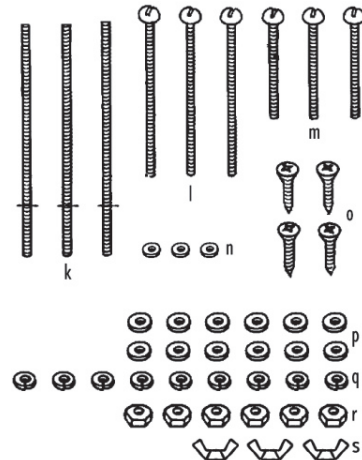
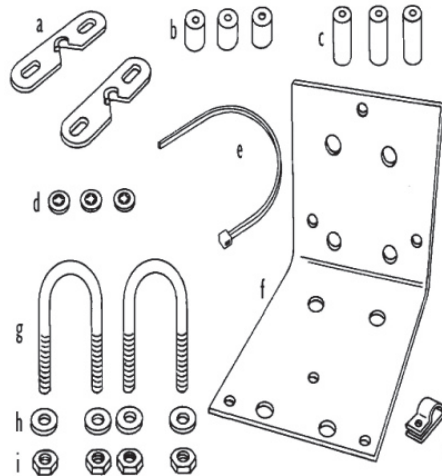

Tools and Materials Needed

You may need the following tools and materials depending on the logger you are using and how you will be mounting the Solar Radiation Shield. Read this manual before beginning the installation to be sure you have everything you need. It is recommended that assemble as much of the shield as you can before going to the field.

- Small Phillips-head screwdriver and medium slotted-head screwdriver
- Wrench or pliers
- Drill with 3/16 in drill bit (4.7 mm) to drill pilot holes if attaching Solar Radiation Shield to the top of a post
- Adjustable wrench or 11/32 in. wrench and 7/16 in. wrench to tighten hex nuts (11/32 in wrench) or to drive lag screws into wall or post (7/16 in wrench)
- Four 3/4 in x 1-1/2 in. lag screws (38 mm long) to attach Solar Radiation Shield to a post or wall
- Three #8 x 1 in. screws (25 mm long) to attach Solar Radiation Shield on the top of a post (if #8 x 2-3/4 in. pan head screws provided create clearance problems)
- Tape to hold screws in place when assembling Solar Radiation Shield

Location Recommendations

Use the following guidelines to determine the best location for mounting the Solar Radiation Shield.

- The Solar Radiation Shield works best when in a location with a steady breeze. Mount away from fences, buildings, trees, or other obstructions.
- Install over plants or soil if possible.
- Do not install over or near sprinklers. The Solar Radiation Shield is not designed to protect the sensor from water sprayed upwards.
- If attaching to a building, the preferred location is the north side in the northern hemisphere and the south side in the southern hemisphere.

Mounting Options

The Solar Radiation Shield may be mounted in three orientations.

- On the side of a wooden post or a wall
- On a metal pipe with outside diameter between 1 in. and 1-1/4 in. (25 mm and 31 mm)
- On top of a wood post

Determine which orientation best suits your needs before you begin because the installation instructions differ slightly depending on how you plan to mount the Solar Radiation Shield. Note that if you are mounting to the side of a post or wall, you will be attaching the mounting bracket to the top of the shield (top mounting). If you are mounting to top of a post, you will be attaching the bracket to the bottom of the shield (bottom mounting).

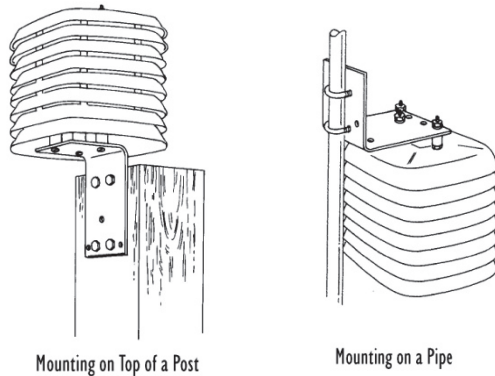
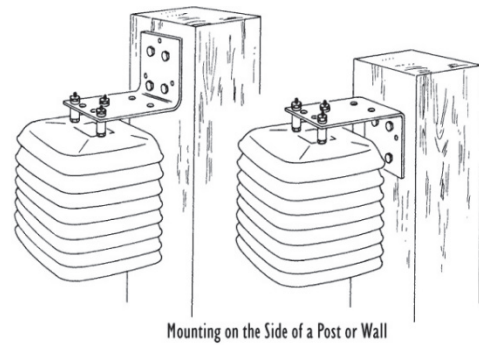

Attaching HOBO Loggers

To attach a HOBO Pendant logger (UA-00x-xx) or a TidbiT v2 (UTBI-001) to the Solar Radiation Shield, install the 1/2 in. screw eye provided with the RS1 into the standoff of the closed plate as shown. Attach the logger with a tie wrap.

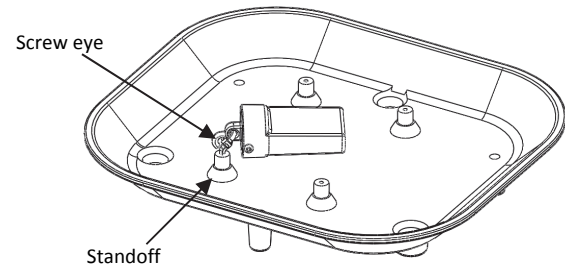

To attach a HOBO Water Temp Pro v2 (U22-001) or a HOBO Pro v2 Internal Temp/RH logger (U23-00x) to the Solar Radiation Shield, place the logger in the clamp provided in the U23 Clamp Kit. Secure the clamp into the standoff on the closed plate as shown with the screw and washer provided in the kit. Note: The HOBO Water Temp Pro v2 can be mounted into the shield using the U23 Clamp Kit, but the clamp fit will not be as snug as it is for the HOBO Pro v2 Internal Temp/RH logger.

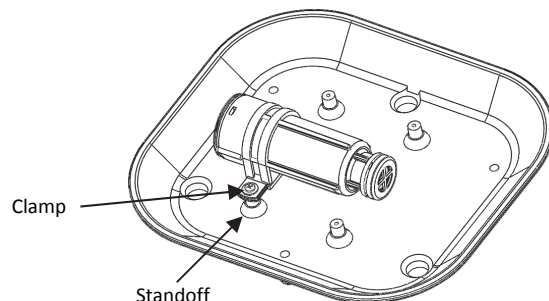

If using a HOBO MX2301 or MX2305 series logger with the Solar Radiation Shield, attach the logger and bracket (MX2300-RS-BRACKET) to the underside of the closed plate with the screws included with the bracket as shown below.

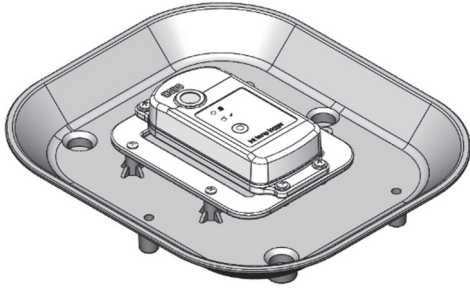

Attaching an External Temperature Sensor from a HOBO Logger

1. Place the sensor cable into the notch on one of the clip mounts and hold it in place. Hold the clip mount so the raised semi-circle at the top of the notch will face up.
2. Position the second clip mount over the first, with the notch facing in the opposite direction, securing the sensor cable between the two notches. When positioning the second clip mount, make sure the raised semi-circle will face down.
3. Position the clip mounts over two of the mounting posts on the closed plate. Make sure you orient the clip mounts as shown at right.
4. Attach the clip mounts to the mounting posts using two of the #4 x 1/2 in. pan head self-threading screws and two of the #4 flat washers.

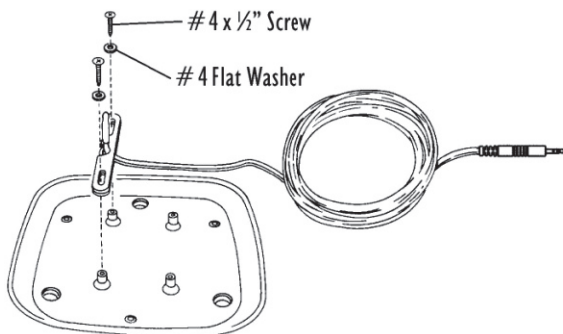

5. Once secured, adjust the sensor so that it and approximately 1/4 in. (6 mm) of cable protrude from the clip mounts.
6. Place the cable clamp around the sensor cable approximately 8 in. (20 cm) from the sensor.

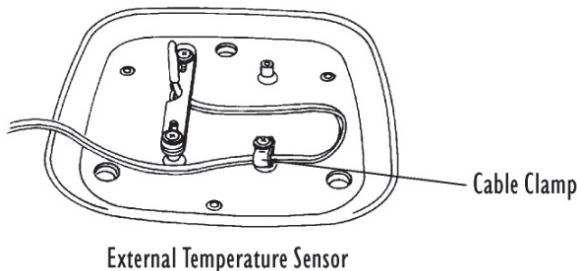

7. Secure the cable clamp to one of the remaining mounting posts (using a #4 x 1/2 in. pan head self-threading screw

and a #4 flat washer) so that a loop of cable is formed. Make sure to mount the clamp so that the flat side will be up and the bulge side down. Tighten the screw completely so that the cable cannot move within the cable clamp.

Assembling the Solar Radiation Shield to Attach to the Side of a Post, Wall, or Pipe

The following instructions explain how to assemble the mounting bracket to the top of the Solar Radiation Shield for installation on the side of a post, a wall, or on a pipe. If you plan to mount the Solar Radiation Shield on top of a post, follow the instructions in Assembling the Solar Radiation Shield to Attach to the Top of a Post on page 5.

Assembling the Solar Radiation Shield Plates

1. Slide each of the three #8 x 5 in. threaded rods, with push nuts installed, through each of the three holes in the three open plates. When inserting the threaded rods, make sure the long end (when measured from the push nut) goes through the holes in the open plates.
2. If you are using an external temperature sensor, feed the entire remaining length of external temperature sensor cable attached to the closed plate through the open centers of the three open plates.
3. Slide the closed plate with the logger over the threaded rod ends protruding from the top of the open plates so that logger is enclosed within the center of the open plates.
4. Slide the flat plate over the threaded rod ends protruding from the closed plate with the logger.
5. Place plastic screw retainers over the protruding threaded rod ends.
6. Rest the partially assembled Solar Radiation Shield on a flat surface and go to the next section.

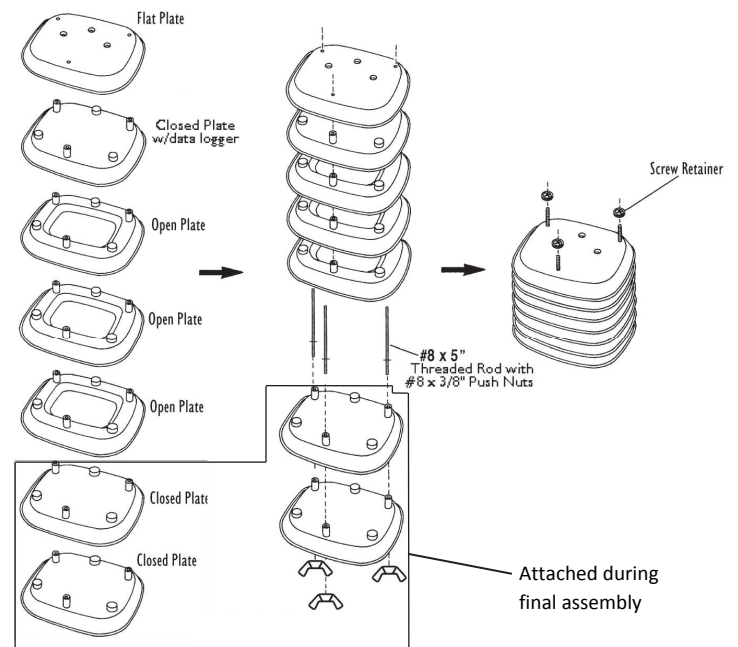

Assembling the Radiation Shield Plates

Attaching the Support Plate to the Cover Plate

1. Slide the three #8 x 2-3/4 in. pan head screws up through the non-threaded holes in the shield support plate. Make sure the side of the support plate marked "UP" is in fact on top as you slide the screws in from the bottom.
2. Place the cover plate over the screw ends protruding from the support plate.
3. Place a 1-inch spacer over each of the screw ends.
4. Secure the support plate and spacers to the cover plate using a #8 flat washer, #8 split lock washer, and #8 hex nut on each of the screw ends. Tighten until the support plate is firmly attached to the cover plate and then go to the next section.

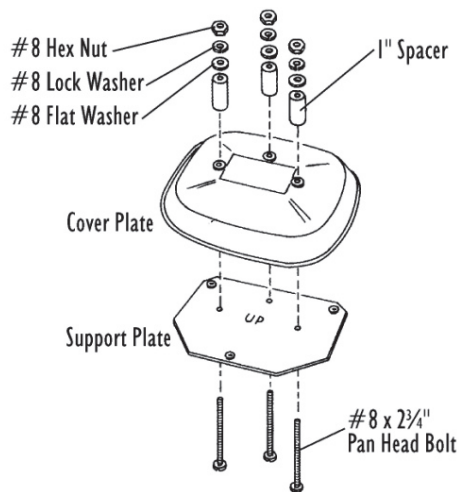

Attaching Support Plate to Cover Plate

Attaching the Cover Plate Assembly to the Solar Radiation Shield

1. Place the cover plate assembly onto the stack of plates, lining up the threaded rod ends with the threaded holes in the bottom of the support plate.
2. With your finger, screw the three #8 x 5 in. threaded rods into the support plate until tight. Go to the next section.

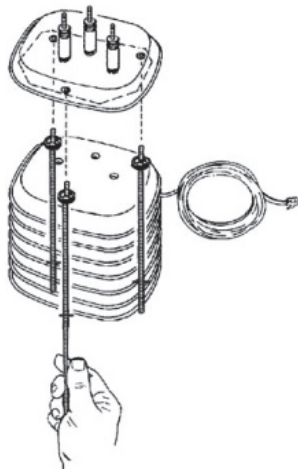

Attaching the Cover Plate Assembly to Solar Radiation Shield

Completing the Final Assembly

1. Slide the lower closed plates over the threaded rods protruding from the bottom of the partially assembled Solar Radiation Shield. If you are using an external temperature sensor, make sure the sensor cable is pulled completely through the space between the lower open plate and the adjacent closed plate during this final assembly.
2. Screw the #8 wing nuts on the threaded rods protruding from the bottom of the assembled Solar Radiation Shield until they are snug. Do not over tighten the wing nuts so they can be easily removed for quick access to the logger for reading out with a HOBO Shuttle.

Mounting on the Side of a Post or Wall

1. Using four 1/4 in. x 1-1/2 in. lag screws, attach the mounting bracket to the mounting surface in the desired location.

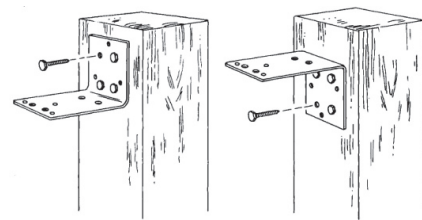

Attaching the Mounting Bracket to the Side of a Post

2. Slide the screw ends protruding from the top of the Solar Radiation Shield assembly into the holes on the mounting bracket.
3. Secure the mounting bracket to the Solar Radiation Shield using a #8 flat washer, #8 split lock washer and #8 hex nut on each of the screw ends. Tighten until the mounting bracket is firmly attached to the Solar Radiation Shield.

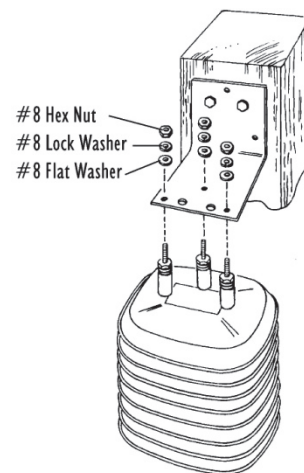

Attaching Solar Radiation Shield to Mounting Bracket

Mounting to a Pipe

These instructions are for mounting to a pipe with an outside diameter between 1 and 1-1/4 inches (25 and 31 mm).

1. Slide the screw ends protruding from the top of the Solar Radiation Shield assembly into the holes on the mounting bracket.

- Secure the mounting bracket to the Solar Radiation Shield using a #8 flat washer, #8 split lock washer, and #8 hex nut on each of the screw ends. Tighten until the mounting bracket is firmly attached to the Solar Radiation Shield.

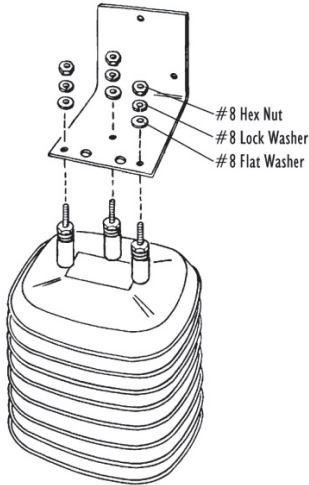

Attaching Solar Radiation Shield to Mounting Bracket

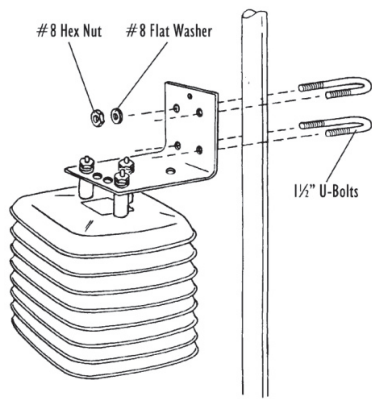

Attaching Mounting Bracket to a Pipe

- Hold the mounting bracket against the pipe and slide the ends of the two 1-1/2 in. U-bolts through the holes in the back of the mounting bracket so that the U-bolts wrap around the pipe.
- Secure the mounting bracket to the pipe using a 1/4 in. flat washer and a 1/4 in. hex nut on each end of the 1-1/2 in. U-bolts. Tighten until the mounting bracket is firmly attached to the pipe.

Assembling the Solar Radiation Shield to Attach to the Top of a Post

The following instructions explain how to assemble the mounting bracket to the bottom of the Solar Radiation Shield for installation on the top of a post. If you plan to mount the Solar Radiation Shield to the side of a post, a wall, or on a pipe, follow the instructions in Assembling the Solar Radiation Shield to Attach to the Side of a Post, Wall, or Pipe on page 3.

Attaching Mounting Bracket

- Using a drill with a 3/16 in. (4.7 mm) drill bit, drill three holes through one of the closed plates in the locations marked by the small dimples on the bottom of the plate. Do not use the closed plate to which you attached the logger or sensor.

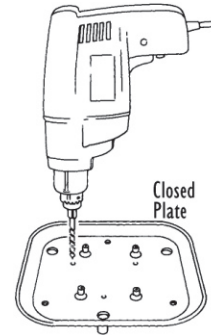

Drilling Holes in Closed Plate

- Place a #8 flat washer over the end of each of the #8 x 2-3/4 in. pan head screws. If the extra length of the screw end protruding from the bottom of the Solar Radiation Shield creates a clearance problem, you will need to use #8 x 1 in. screws (not included).
- Slide the three #8 x 2-3/4 in. pan head screws (with washers) up through the holes you just drilled.
- Place a small piece of tape over each of the screw heads to keep the screws in place as you continue.
- Place a 1/2 in. spacer over each of the screw ends protruding from the closed plate.
- Slide the mounting bracket over the screw ends protruding from the closed plate.
- Secure the mounting bracket to the closed plate using a #8 flat washer, a #8 split lock washer, and a #8 hex nut on each of the screw ends. Tighten until the mounting bracket is firmly attached to the closed plate and then go to the next section.

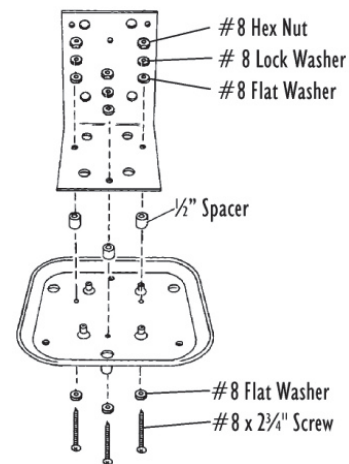

Attaching Mounting Bracket

Assembling the Solar Radiation Shield Plates

1. Slide each of the three #8 x 5 in. threaded rods, with push nuts installed, through each of the three holes in the three open plates. When inserting the threaded rods, make sure the long end (when measured from the push nut) goes through the holes in the open plates.
2. If you are using an external temperature sensor, feed the entire remaining length of external temperature sensor cable attached to the closed plate through the open centers of the three open plates.
3. Slide the closed plate with the logger over the threaded rod ends protruding from the top of the open plates so that logger is enclosed within the center of the open plates.
4. Slide the flat plate over the threaded rod ends protruding from the closed plate with the logger.
5. Place plastic screw retainers over the protruding threaded rod ends.
6. Rest the partially assembled Solar Radiation Shield on a flat surface and go to the next section.

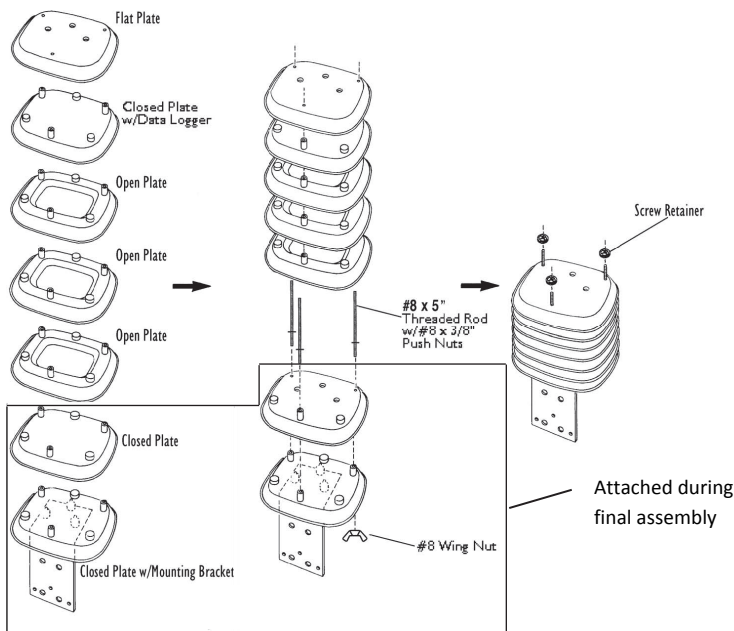

Assembling the Radiation Shield Plates

Attaching the Support Plate to the Cover Plate for Top Mounting

1. Slide the three #8 x 2-3/4 in. pan head screws up through the non-threaded holes in the shield support plate. Make sure the side of the support plate marked "UP" is in fact on top as you slide the screws in from the bottom.
2. Place the cover plate over the screw ends protruding from the support plate.
3. Secure the support plate and spacers to the cover plate using a #8 flat washer, #8 split lock washer, and #8 hex nut

on each of the screw ends. Tighten until the support plate is firmly attached to the cover plate and then go to the next section.

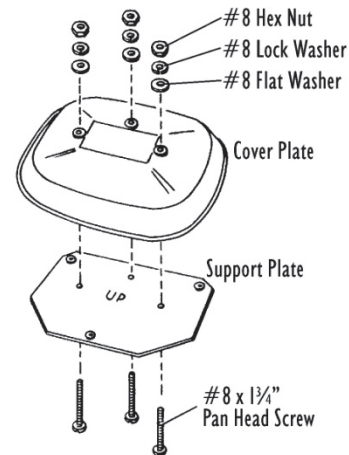

Attaching Support Plate to Cover Plate

Attaching the Cover Plate Assembly to the Solar Radiation Shield

1. Place the cover plate assembly onto the stack of plates, lining up the threaded rod ends with the threaded holes in the bottom of the support plate.
2. With your finger, screw the three #8 x 5 in. threaded rods into the support plate until tight. Go to the next section.

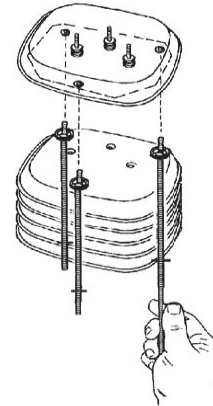

Attaching the Cover Plate Assembly to Solar Radiation Shield

Completing the Final Assembly

1. Slip the exposed ends of the #8 x 5 in. threaded rods through the holes in the open plate and then the closed plate with mounting brackets.
2. Screw the #8 wing nuts onto the exposed ends of the #8 x 5 in. threaded rods and tighten until snug. Go to the next section.

Mounting to the Top of a Post

1. The mounting bracket should have already been installed on the shield.
2. Use four 1/4 x 1-1/2 in. lag screws (not included) to attach the mounting bracket to the mounting surface in the desired location.

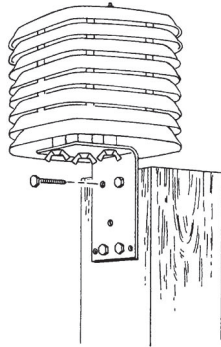

Attaching Mounting Bracket to the Top of a Post

Reading Out the Logger

To read out HOBO MX2300 loggers that do not have power saving mode enabled, stand within communication range of the shield and logger with a mobile device and use HOBOMobile® to connect to the logger and read it out.

For MX2300 loggers with power saving mode enabled and all other loggers, follow these steps to read out the data from the logger:

1. Remove the bottom plates for a top-mounted shield, or remove the top plates for a bottom-mounted shield.
2. If you are reading out a HOBO Pendant logger (UA-00x-xx) or a TidbiT v2 (UTBI-001), you can keep the logger attached to the shield while offloading data.

If you are reading out a MX2300 logger with power saving mode enabled, keep the logger attached to the shield. Press the button on the logger to wake up communications. Use HOBOMobile to connect to the logger and read it out.

If you are reading out a HOBO Water Temp Pro v2 (U22-001) or a HOBO Pro v2 Internal Temp/RH logger (U23-00x), unscrew the clamp that secures the logger to the shield and remove the logger. After reading out the logger, place it back in the clamp and screw it back in.

3. Reattach the bottom or top plates as applicable.

Maintenance Instructions

- The effectiveness of the Solar Radiation Shield will be reduced if the surfaces of the shield become dirty. Wipe the surfaces of the shield using a damp cloth to remove dirt, debris, etc.
- Keep areas between Solar Radiation Shield plates free of debris that may obstruct air flow e.g., leaves, twigs, webs, nests. DO NOT remove nesting insects or animals by spraying insect killer of any kind into the Solar Radiation Shield because this may damage the sensors and the Solar Radiation Shield.