

R5020

REED INSTRUMENTS

AC Clamp Meter



Instruction Manual

Table of Contents

Introduction	3
Product Quality.....	3
Safety	3-4
Features.....	4
Included.....	4
Specifications	5-6
Instrument Description	7
Display Description	8
Operating Instructions.....	9-12
<i>Connecting the Test Leads</i>	9
<i>AC Current Measurements</i>	9
<i>AC/DC Voltage Measurements</i>	9
<i>Resistance Measurements</i>	10
<i>Diode and Continuity Measurements</i>	10
<i>Capacitance Measurements</i>	11
<i>Frequency or % Duty Cycle measurements</i>	11
<i>Type K Temperature Measurements</i>	11
<i>Non-Contact AC Voltage Measurements</i>	12
<i>Auto Power Off</i>	12
<i>Data Hold</i>	12
<i>Relative Mode</i>	12
Battery Replacement.....	13
Applications.....	13
Accessories and Replacement Parts	13
Product Care	14
Product Warranty	14
Product Disposal and Recycling	14
Product Support.....	15

Introduction

Thank you for purchasing your REED R5020 AC Clamp Meter. Please read the following instructions carefully before using your instrument. By following the steps outlined in this manual your meter will provide years of reliable service.

Product Quality

This product has been manufactured in an ISO9001 facility and has been calibrated during the manufacturing process to meet stated product specifications. If a certificate of calibration is required please contact the nearest authorized REED distributor or authorized Service Center. Please note an additional fee for this service will apply.

Safety

- Never attempt to repair or modify your instrument. Dismantling your product, other than for the purpose of replacing batteries, may cause damage that will not be covered under the manufacturer's warranty. Servicing should only be provided by an authorized service center.
- Do not exceed the maximum allowable input range of any function.
- Do not apply voltage to the meter when resistance function is selected.
- Set the rotary switch to OFF when the meter is not in use.
- Set the rotary switch to the appropriate position before measuring.
- When measuring volts do not switch to current/resistance modes.
- Disconnect the test leads from the circuit under test before changing the position of the rotary switch.
- Do not exceed the maximum rated input limits.
- Improper use of this meter can cause damage, shock, injury or death.
- Always remove the test leads before replacing the battery.
- Inspect the condition of the test leads and the meter itself for any damage before operating.
- Use great care when taking measurements if the voltages are greater than 25VAC RMS or 35VDC as they are considered a shock hazard.

continued...

- Remove the battery if the meter is to be stored for a long period of time.
- Always discharge capacitors and remove power from the device under test before performing diode, resistance, or continuity tests.
- Voltage checks on electrical outlets can be difficult and misleading because of the uncertainty of connection to the recessed electrical contacts.

Features

- Measures AC current, AC/DC voltage, resistance, capacitance, frequency, duty cycle and temperature
- 4000-count LCD display with low battery and overrange indicators
- Built-in non-contact voltage detector with LED indicator
- Display hold and relative mode
- Diode test and continuity check functions
- Durable double molded plastic housing
- Cat. III 600V safety rating

Included

- Test Leads
- Thermocouple Wire Probe
- Thermocouple Adapter
- Batteries
- Soft Carrying Case

Specifications

AC Current

Range:	40, 400A
Accuracy:	AC: $\pm(2.5\% \text{ rdg.} + 8 \text{ dgt.})$
Resolution:	0.01, 0.1A

AC/DC Voltage

Range:	AC: 4, 40, 400, 600V DC: 400mV, 4, 40, 400, 600V
Accuracy:	AC: $\pm(1.8\% \text{ rdg.} + 8 \text{ dgt.})$ DC: $\pm(1.5\% \text{ rdg.} + 2 \text{ dgt.})$
Resolution:	AC: 0.001, 0.01, 0.1, 1V DC: 0.1mV, 0.001, 0.01, 0.1, 1V

Resistance

Range:	400 Ω , 4, 40, 400k Ω , 4, 40M Ω
Accuracy:	$\pm(1.5\% \text{ rdg.} + 2 \text{ dgt.})$ 0.1 Ω , 0.001, 0.01, 0.1k Ω , 0.001, 0.01M Ω

Capacitance

Range:	40, 400nF, 4, 40, 100 μ F
Accuracy:	$\pm(3\% \text{ rdg.} + 5 \text{ dgt.})$
Resolution:	0.01, 0.1nF, 0.01, 0.1 μ F

Frequency

Range:	10MHz
Accuracy:	$\pm(1.2\% \text{ rdg.} + 2 \text{ dgt.})$
Resolution:	0.01Hz

Temperature

Range:	-4 to 1400°F (-20 to 760°C)
Accuracy:	$\pm(3.0\% \text{ rdg.} + 9^\circ\text{F})$ $\pm(3.0\% \text{ rdg.} + 5^\circ\text{C})$
Resolution:	1°F, 1°C

continued...

General Specifications

Range Selection:	Autoranging/Manual
Display:	4.000 count LCD display
Display Hold:	Yes
Relative Mode:	Yes
Diode Test:	Yes
Continuity Check:	Audible signal if resistance $<150\Omega$
Duty Cycle:	Yes
Non-Contact Voltage Detector:	Yes
Autoshut off:	Yes (after 15 minutes)
Power Supply:	2 x AAA Batteries
Low Battery Indicator:	Yes
Jaw Opening:	1.2" (30mm), up to 350 MCM
Overvoltage Category:	CAT. III 600V
Product Certifications:	CE
Operating Temperature:	32 to 122°F (0 to 50°C)
Storage Temperature:	-4 to 140°F (-20 to 60°C)
Dimensions:	7.9 x 2.6 x 1.5" (200 x 66 x 37mm)
Weight:	7.2oz (205g)

Instrument Description

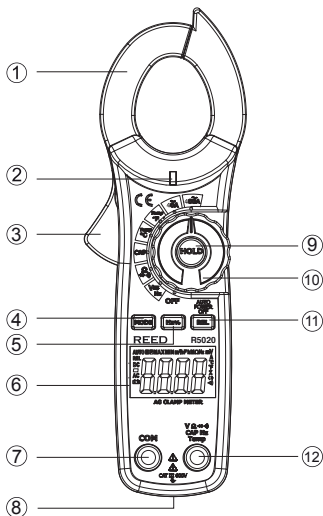

- | | |
|---|-------------------------------|
| 1. Current Clamp | 7. COM Input Jack |
| 2. Non-contact AC Voltage Indicator Light | 8. Battery Cover |
| 3. Clamp Trigger | 9. Data Hold Button |
| 4. MODE Selection Button | 10. Rotary Switch |
| 5. Frequency/Duty Cycle Selection Button | 11. Relative Button |
| 6. LCD Display | 12. VΩ CAP TEMP Hz Input Jack |

Display Description

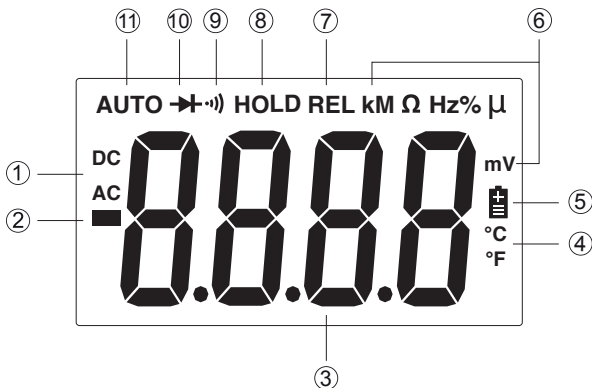

1. AC/DC Indicator
2. Negative Reading Indicator
3. 4000 Count Main Display
4. Temperature Units
5. Low Battery Indicator
6. Units of Measurement
7. Relative Mode Indicator
8. Data Hold Indicator
9. Audible Continuity Indicator
10. Diode Test Mode Indicator
11. Auto Range Mode Indicator

Operating Instructions

Connecting the Test Leads

Connect the red test lead to the $V\Omega$ Input Jack and the black test lead to the COM Input Jack.

AC Current Measurements

Warning:
Disconnect the test leads before making clamp measurements.

1. Set the rotary switch to the 400 or 40A range. If the required range is unknown, select the higher range first then move to the lower range if necessary.
2. Press the trigger to the open jaw and fully enclose one conductor only as shown.
3. The LCD will display the reading.

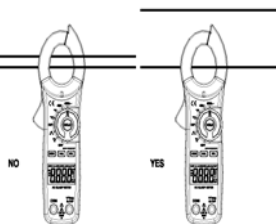

AC/DC Voltage Measurements

1. Set the rotary switch to the V position, and select either AC or DC using the **MODE** button.
2. Connect the test leads to the meter (see *Connecting the Test Leads* section for details).
3. Connect the test leads in parallel to the circuit under test as shown.
4. The LCD will display the reading.

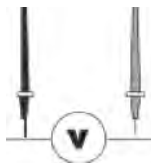

continued...

Resistance Measurements

1. Set the rotary switch to the Ω position.
2. Connect the test leads to the meter (see *Connecting the Test Leads* section for details).
3. Touch the test probe tips across the circuit or component under test as shown.

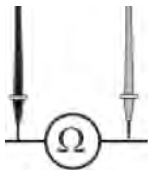

Note: It is best to disconnect one side of the device under test so the rest of the circuit will not interfere with the reading.

4. The LCD will display the reading.

Diode and Continuity Measurements

1. Set the rotary function switch to the Ω position.
2. Connect the test leads to the meter (see *Connecting the Test Leads* section for details).
3. Press the **MODE** button until the Diode Test indicator $\rightarrow|+$ appears on the LCD display.
4. Touch the test probes to the diode under test as shown. Forward voltage will indicate 0.4V to 0.7V. Reverse voltage will be indicated by "OL". Shorted devices will indicate near 0mV and an open device will be indicated by "OL" in both polarities. For Continuity tests, if the resistance is <150 , a tone will sound.

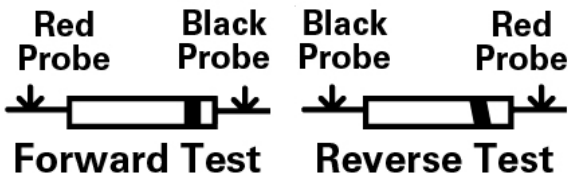

continued...

Capacitance Measurements

1. To avoid electric shock, disconnect power to the unit under test and discharge all capacitors before taking any capacitance measurements. Remove the batteries and unplug the line cords.
2. Set the rotary function switch to the CAP position.
3. Connect the test leads to the meter (see *Connecting the Test Leads* section for details).
4. Touch the test leads to the capacitor under test as shown.
5. Note the capacitance value on the LCD display.

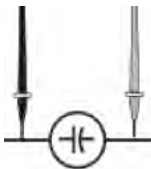

Frequency or % Duty Cycle measurements

1. Set the rotary function switch to the V position.
2. Connect the test leads to the meter (see *Connecting the Test Leads* section for details).
3. Select Hz or % duty with the **Hz/%** button.
4. Touch the test probe tips to the circuit under test as shown.
5. Note the frequency or % duty cycle value on the LCD display.

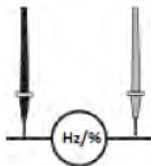

Type K Temperature Measurements

Note: To avoid electric shock, disconnect both test probes from any source of voltage before making a temperature measurement.

1. Set the rotary function switch to °C or °F.
2. Plug the optional Type K Thermocouple Probe into the thermocouple input jack.
3. Touch the Temperature Probe head to the area to be measured.
4. When the reading is stable (up to 30 seconds), note the measured value.

Note: In case of an open input or a temperature overrange, the meter will display "OL". To avoid electric shock, be sure the thermocouple has been removed before changing to another function.

continued...

Non-Contact AC Voltage Measurements

1. Set the rotary function switch any measurement position.
2. Place the tip of the meter to the hot conductor under test or the hot side of the electrical outlet.
3. If AC voltage is present, the detector will light up.

Note: The conductors in electrical cord sets are often twisted. For best results, rub the probe tip along a length of the cord to assure placing the tip in close proximity to the live conductor. The detector is designed with high sensitivity. Static electricity or other sources of energy may randomly trip the sensor.

Auto Power Off

To preserve battery life, the meter is programmed to turn off after approx. 30 minutes of inactivity.

Data Hold

1. While taking a measurement, press the **HOLD** button to freeze the current reading on the display.
2. While in this mode a "HOLD" symbol will appear on the LCD.
3. Press the **HOLD** button again to resume normal operation.

Relative Mode

1. Press the **REL** button to enter relative mode which will zero the reading and create a reference point.
2. REL will appear on the LCD display. Future readings will display a value that is the difference between the actual reading and the stored relative reading.

Note: While in Relative mode, auto ranging is disabled and measurements are limited to the range that is active when the **REL** button was pressed.

3. Press the **REL** button to exit relative mode and resume normal operation.

Note: Relative mode does not function in Frequency or Duty Cycle mode.

Battery Replacement

1. Remove the 2x Phillips head screws that secure the battery cover.
2. Remove the battery cover.
3. Replace the 2 x AAA batteries.
4. Properly secure the cover and tighten the screws.

Applications

Industrial maintenance teams performing scheduled and preventative maintenance on electro-mechanical equipment and systems.

Facilities, building maintenance and electricians looking to troubleshoot electrical equipment installation problems.

Accessories and Replacement Parts

- **R2920** Surface Thermocouple Probe
- **R2930** Right Angle Thermocouple Probe
- **R2940** Air/Gas Thermocouple Probe
- **R2950** Immersion Thermocouple Probe
- **R2960** Needle Tip Thermocouple Probe
- **R5400** Line Splitter
- **LS-181** Type K Male Connector
- **LS-109** Type K Surface Probe
- **TP-01** Type K Beaded Wire Probe
- **LS-182** Type K Female Connector
- **R1020** Fused Test Lead Set
- **R1000** Safety Test Lead Set
- **CA-52A** Small Soft Carrying Case
- **R9940** Hard Shell Carrying Case
- **R2990** Thermocouple Adapter

Don't see your part listed here? For a complete list of all accessories and replacement parts visit your product page on www.reedinstruments.com.

Product Care

To keep your instrument in good working order we recommend the following:

- Store your product in a clean, dry place.
- Change the battery as needed.
- If your instrument isn't being used for a period of one month or longer please remove the battery.
- Clean your product and accessories with biodegradable cleaner. Do not spray the cleaner directly on the instrument. Use on external parts only.

Product Warranty

REED Instruments guarantees this instrument to be free of defects in material or workmanship for a period of one (1) year from date of shipment. During the warranty period, REED Instruments will repair or replace, at no charge, products or parts of a product that proves to be defective because of improper material or workmanship, under normal use and maintenance. REED Instruments total liability is limited to repair or replacement of the product. REED Instruments shall not be liable for damages to goods, property, or persons due to improper use or through attempts to utilize the instrument under conditions which exceed the designed capabilities. In order to begin the warranty service process, please contact us by phone at 1-877-849-2127 or by email at info@reedinstruments.com to discuss the claim and determine the appropriate steps to process the warranty.

Product Disposal and Recycling



Please follow local laws and regulations when disposing or recycling your instrument. Your product contains electronic components and must be disposed of separately from standard waste products.

Product Support

If you have any questions on your product, please contact your authorized REED distributor or REED Instruments Customer Service by phone at 1-877-849-2127 or by email at info@reedinstruments.com.

Please visit www.REEDINSTRUMENTS.com for the most up-to-date manuals, datasheets, product guides and software.

*Product specifications subject to change without notice.
All rights reserved. Any unauthorized copying or reproduction of this manual is strictly prohibited without prior written permission from REED Instruments.*

