

PROALERT 1000



FEATURES

- High Intensity Red Alarm Light
- 90dB Audible Alarm with External Test / Silence / Normal Position
- Rugged NEMA 4X Industrial Enclosure
- Latching Lockable Cover
- Lockable
- External Wall Mounting Feet
- UL Listed Enclosure / (CSA)
- High Impact Plastic Polycarbonate Shell
- Excellent Chemical Resistance
- Includes 6' Power Cord + Watertight Cord Connector

TYPICAL APPLICATIONS

- High / Low Level Indication for Tanks / Sumps
- Bag / Filter Change Out
- Leak Detection
- Flow / No Flow Sensors / Pump Protection
- Upset Condition Notification

SPECIFICATIONS

- Dimensions / 7" X 5" X 4.5"
- Enclosure / NEMA 4X
- Weight / 2.1 lbs.
- 120v / 60Hz / 1 Amp
- Input Power / 100 - 240VAC



ALARM INSTALLATION

- Decide Mounting location.
- Install the unit using the built-in mounting feet.
- Hook the 120VAC plug into a 120VAC receptacle on a separate branch circuit from the one used for the sensor/flow switch to ensure proper notification.
- Connect Switch/Sensor following Manufacturers Instructions.
- Switch the toggle switch to the 'Normal' position. Manually test the alarm by powering the sensor/flow switch until you hear the alarm notification and you see the alarm light turn on.
- Periodically test unit by moving the toggle switch to the 'Test' position recommended prior to filling or draining.
- The audible alarm can be silenced by moving the toggle switch to the 'Silence' position. Ensure the toggle switch is typically left in the "Normal" position for proper alarm notification.



ELECTRICAL SCHEMATIC

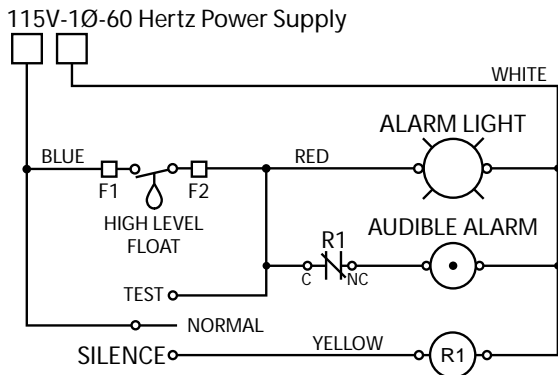

Wiring Diagram for ProAlert

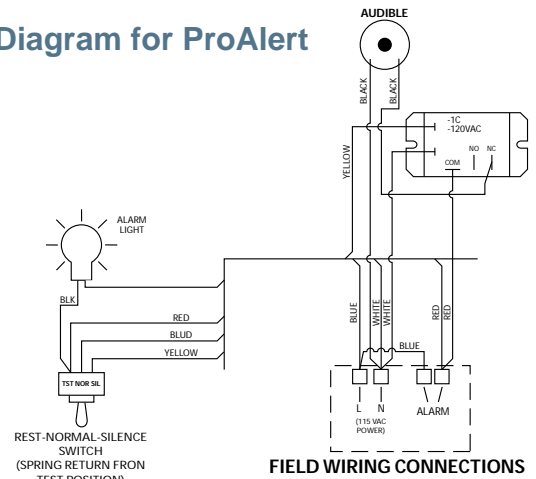

WARNING



ELECTRICAL SHOCK HAZARD

Disconnect power before installing or servicing this product. A qualified service person must install and service this product according to applicable electrical and plumbing codes.

WARNING



EXPLOSION OR FIRE HAZARD

Do not use this product with flammable liquids. Do not install in hazardous locations as defined by CSA, ANSI/NFPA 70.

Failure to follow these precautions could result in serious injury or death. Replace product immediately if switch cable becomes damaged or severed. Keep these instructions with warranty after installation. This product must be installed in accordance with CSA, ANSI/NFPA 70 so as to prevent moisture from entering or accumulating within boxes, conduit bodies, fittings, float housing, or cable.

MODELS

- **PA-1000-** ProAlert
120V - Dry Contact Input
- **PA-1000-PR** - PNP / NPN Pulse
Input - 5AMP Relay Timer Signal Output

