

Pressure Module (PM)

ACCURACY

psi (Gauge Pressure)

30, 100, and 300 psi modules

0 to 30% of Range: $\pm (0.0075\% \text{ of Full Scale})$

30 to 110% of Range: $\pm (0.025\% \text{ of Reading})$

Vacuum: For 30 and 100 psi
 $\pm (0.06\% \text{ of Full Scale}^*)$

For 300 psi
 $\pm (0.06\% \text{ of Full Scale}^*) \pm 1 \text{ LSD}$

* Full Scale = -14.5 psi

1000, 3000, 10 000, and 15 000 psi modules

0 to 30% of Range: $\pm (0.015\% \text{ of Full Scale})$

30 to 110% of Range: $\pm (0.05\% \text{ of Reading})$

Includes all effects of linearity, hysteresis, repeatability, temperature, and stability for one year.

All models indicate vacuum, but vacuum specification applies to 30, 100, and 300 psi models only.

Not recommended for continuous use at high vacuum.

Refer to [XP2i-DP data sheet](#) for gauges that are intended for continuous high vacuum use.

psiA (Pressure with BARO module)

30 psi module

0.200 to 14.500 psiA: $\pm 0.011 \text{ psiA}$

14.500 to 44.500 psiA: $\pm (0.025\% \text{ of Reading})$
 $+ 0.003 \text{ psiA}$

100 psi module

0.200 to 14.500 psiA: $\pm 0.011 \text{ psiA}$

14.500 to 44.500 psiA: $\pm 0.011 \text{ psiA}$

44.500 to 114.500 psiA: $\pm (0.025\% \text{ of Reading})$

300 psi module

0.20 to 14.50 psiA: $\pm 0.01 \text{ psiA}$

14.50 to 104.50 psiA: $\pm 0.03 \text{ psiA}$

104.50 to 314.50 psiA: $\pm (0.025\% \text{ of Reading})$

1000 psi module

14.5 to 314.5 psiA: $\pm 0.2 \text{ psiA}$

314.5 to 1014.5 psiA: $\pm (0.05\% \text{ of Reading})$

3000 psi module

14.5 to 914.5 psiA: $\pm 0.5 \text{ psiA}$

914.5 to 3014.5 psiA: $\pm (0.05\% \text{ of Reading})$

10 000 psi module

15 to 3015 psiA: $\pm 2 \text{ psiA}$

3015 to 10 015 psiA: $\pm (0.05\% \text{ of Reading})$

15 000 psi module

15 to 4515 psiA: $\pm 3 \text{ psiA}$

4515 to 15 015 psiA: $\pm (0.05\% \text{ of Reading})$

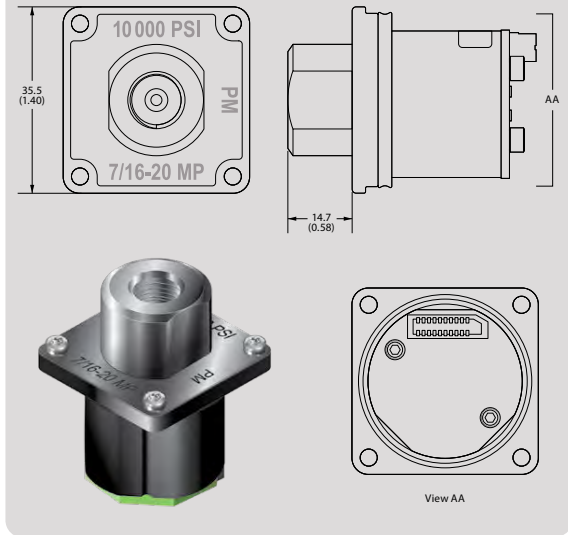

DIFFERENTIAL PRESSURE MEASUREMENT UNCERTAINTIES WITH TARE

The Tare function can improve measurement uncertainties on two modules with the same full scale pressure range installed into one nVision Reference Recorder. Requires the use of an equalizing valve.

The following specifications apply to the measurement system with a logging interval of 1 second/reading:

Full Scale Range of Both Sensors	The Greater of (+/-)				or	% of DP Reading
	psi	mbar	inH ₂ O	mmH ₂ O		
30	0.0005	0.04	0.014	0.4	or	0.025%
100	0.0015	0.10	0.04	1.0	or	0.025%
300	0.005	0.4	0.14	4.0	or	0.025%
1000	0.02	1.0	0.4	10.0	or	0.05%
3000	0.05	4.0	1.4	n/a	or	0.05%
10000	0.2	10.0	4.0	n/a	or	0.05%
15000	0.3	15.0	6.0	n/a	or	0.05%

Unit must be enabled in CrystalControl

DIFFERENTIAL PRESSURE MEASUREMENT UNCERTAINTIES WITHOUT TARE

The total nVision Reference Calibrator measurement uncertainty in the ΔP mode configuration will need to consider the uncertainties of both pressure modules. We recommend the module uncertainties to be combined with the preferred square root of the sum of the squares (or "root sum squares") method.

The following table lists the possible combinations of using Pressure Modules (PM) with different accuracy statements. The uncertainties reported below are without the use of the Tare feature, which will greatly improve your measurement uncertainty.

Lower Pressure Module Uncertainties (of Static Line Pressure) (of Reading)		Upper Pressure Module Uncertainties (of Static Line Pressure) (of Reading)	
		0.025%	0.05%
0.025%	0.025%	0.035%	0.056%
	0.05%	0.056%	0.071%

SENSOR

Wetted Materials: (WRENCH TIGHT) **316 stainless steel**
 (FINGER TIGHT) **316 stainless steel**
and Viton® (internal o-ring)

Diaphragm Seal Fluid: **Silicone Oil**

Connection: **Crystal CPF* Female**

All welded, with a permanently filled diaphragm seal.
Metal to metal cone seal; O-ring can be removed if necessary.
1/4" medium pressure tube system compatible with HIP LMA and LF4 Series, Autoclave Engr SF250CX Male and Female Series.
CPF Adapters to NPT, BSP, and M20 available.
 *U.S. Patent No. 8,794,677

BAROMETRIC REFERENCE (BARO)

Accuracy: **± 0.00725 psi, ± 0.5 mbar**

Range: **10.153 to 15.954 psiA,**
700.0 to 1100.0 mbarA

Units and Resolution: **psi** **0.001**
inHg **0.001**
mmHg **0.01**
mbar **0.1**

Pressure Connection: **Cylindrical sensor fitting of 5.8mm OD. A flexible 4.8 mm [3/16"] ID tube is recommended to connect for calibration.**

Mounting: **Secured using a 3/8" 4-40 plastic screw.**

Includes all effects of linearity, hysteresis, repeatability, temperature, and stability for one year.
Exposure to environmental extremes of temperature, shock, and/or vibration may warrant a more frequent recertification period.
Other units available depending on the installed modules.
Plastic non-conductive screw must be used to comply with hazardous location requirements.



Current, Voltage, & Switch Test Module (MA20)

Intended for use with a 4-20mA loop measurement. This module is also capable of measuring supply voltages and has an auxiliary fixed output for use in switch open/closure testing. Each MA20 module includes a super flexible silicone test lead kit (P/N 3952).

CURRENT & VOLTAGE MEASUREMENT

Current (mA) Input

Accuracy: $\pm (0.015\% \text{ of rdg} + 0.002 \text{ mA})$

Range: **0 to 55 mA (MA20)**

Max Allowable Current: **93.3 mA**

Resolution: **0.001 mA or 0.01%**

Units: **mA, % 4-20, % 10-50**

Input Resistance: **< 17.2 Ω**

Voltage Burden @ 20mA: **< 0.35 V**

Voltage Burden @ 50mA: **< 0.86 V**

HART Resistance: **250 Ω**

Connection: **2mm jacks**

Includes all effects of linearity, hysteresis, repeatability, temperature, and stability for one year.

For hazardous location product warnings, refer to the operation manual.

Inputs protected by a resettable fuse.

mA can be displayed as a percentage, where 0 to 100% corresponds to either 4 to 20 mA or 10 to 50 mA.

Jacks are compatible with safety sheathed banana plugs.

Voltage (VDC) Input

Accuracy: $\pm (0.015\% \text{ of rdg} + 0.002 \text{ VDC})$

Range: **0 to 28 VDC**

Max Allowable Voltage: **30 VDC**

Resolution: **0.001 VDC**

Units: **VDC**

Includes all effects of linearity, hysteresis, repeatability, temperature, and stability for one year.

Switch Test

Switch Type: **Dry Contact**

Closed State Resistance: **< 10 Ω**

Open State Resistance: **> 10 M Ω**

Switch state change indicated by bright green LED flash.

Switch test screen reports switch open, close, and deadband values.

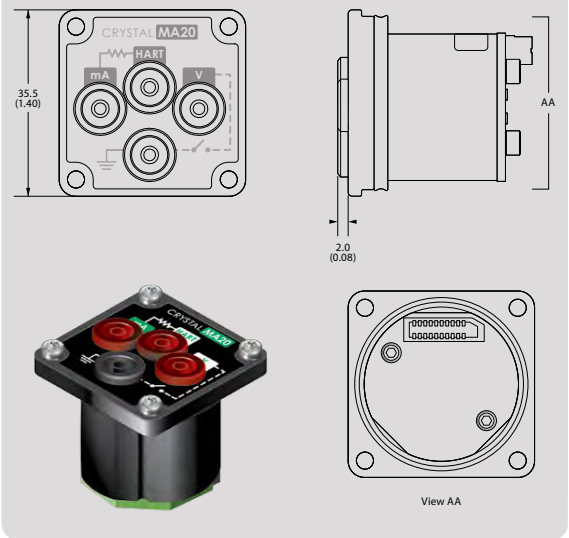

ATEX IEC IECEx ATEX and IECEx Scheme Entity Parameters

The MA20 Module has these specific input entity parameters:

- Ui = 28 V**
- li = 93.3 mA**
- Pi = 653.3 mW**
- Ci = 0.36 uF**
- Li = 39.1 uH**
- Uo = 6.6 V**
- Io = 4.45 mA**
- Po = 7.34 mW**
- Co = 0.5 uF***
- Lo = 12 uH****

* Dependent on the supply to the terminals but shall not be greater than 0.5 uF
 ** Total cable inductance between all modules

Temperature Module (RTD100)

Calibrated for Pt100 RTD/PRT (100 Ohms at 0°C Platinum Resistance Temperature Detector) sensors conforming to DIN/IEC 60751 (or IEC751) with US, Euro, or Lab calibration curves. An RTD is not included, but each RTD100 includes P/N 3953 RTD Connection Kit.

TEMPERATURE MEASUREMENT

Resistance Input

Accuracy: $\pm (0.015\% \text{ of rdg} + 0.02 \Omega)$

Range: **0 – 400 Ohms range for use with 100 Ohm PRTs**

Resolution: **0.01 on all scales**

Units: °C, K, °F, R, Ω

TCRs: **0.003850 $\Omega/\Omega/^\circ\text{C}$ (IEC 60751), 0.003911 $\Omega/\Omega/^\circ\text{C}$ (US Industrial Std), 0.003926 $\Omega/\Omega/^\circ\text{C}$**

Wiring: **2-, 3-, 4-wire support**

Connection: **M8 connector cable or terminal block**

Includes all effects of linearity, hysteresis, repeatability, temperature, and stability for one year.

The proper selection of the RTD sensing element is very important as the error associated with this device is the majority of the overall system measurement uncertainty. IEC 751 is the standard that defines the temperature versus resistance for 100 Ω , 0.00385 $\Omega/\Omega/^\circ\text{C}$ platinum RTDs. IEC 751 defines two classes of RTDs: Class A and B. Class A RTDs operate over the -200 to 630°C range versus -200 to 800°C for the Class B elements. For example, the Class A uncertainty is about half that of the Class B elements as illustrated in the following table.

Temperature °C	nVision Uncertainty		Class A				Class B			
	Class A Uncertainty		nVision + Class A Uncertainty		Class B Uncertainty		nVision + Class B Uncertainty			
	$\pm\Omega$	$\pm^\circ\text{C}$	$\pm\Omega$	$\pm^\circ\text{C}$	$\pm\Omega$	$\pm^\circ\text{C}$	$\pm\Omega$	$\pm^\circ\text{C}$	$\pm\Omega$	$\pm^\circ\text{C}$
-200	0.02	0.05	0.24	0.55	0.24	0.55	0.56	1.30	0.56	1.30
0	0.04	0.09	0.06	0.15	0.07	0.17	0.12	0.30	0.12	0.31
200	0.05	0.13	0.2	0.55	0.21	0.56	0.48	1.30	0.48	1.31
400	0.06	0.17	0.33	0.95	0.33	0.96	0.79	2.30	0.79	2.31
600	0.07	0.21	0.43	1.35	0.44	1.37	1.06	3.30	1.06	3.31
800	0.08	0.25	0.52	1.75	0.53	1.77	1.28	4.30	1.28	4.31

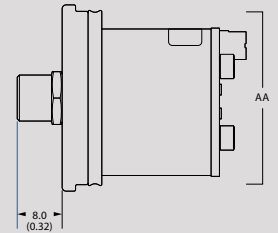
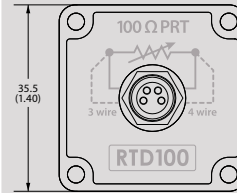

M8 connector cable or terminal block. Works with 2-, 3-, 4-wire RTDs.

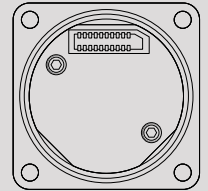

View AA

ATEX IEC IECEx ATEX and IECEx Scheme Entity Parameters

The RTD100 Module has these specific input entity parameters:

- Ui = 0 V**
- li = 0 A**
- Pi = 0 W**
- Uo = 9.73 V**
- Io = 1.6642 A**
- Po = 1.1 W**
- Co = 0.5 uF**
- Lo = 12 uH***

* Total cable inductance between all modules

nVision Chassis (NV)

OPERATING TEMPERATURE

Temperature Range: **-20 to 50° C (-4 to 122° F)**

< 95% RH, non-condensing. No change in accuracy over operating temperature range. Gauge must be zeroed to achieve rated specification.

Applies to all modules.

DISPLAY

Screen: **255 x 160 pixel graphical display**

LCD readable in sunlight with bright backlight.

Display Rate: **4 readings/second (standard)**

up to 10 readings/second (recording)

POWER

The nVision is Intrinsically Safe only if powered by one of the following battery types.

ATEX/IECEx:	Approved Battery Type	Ta=	Marking
	Rayovac Max Plus 815	-20 to 50° C	Ex ia IIB T4 Ga
	Duracell MN1500	-20 to 45° C	
	Energizer E91, EN91	-20 to 50° C	Ex ia IIB T3 Ga
	Duracell MN1500		

CSA:	Approved Battery Type	Ta=	Marking
	Rayovac Max Plus 815	-20 to 50° C	Class I, Division 1, Grp C, D T4
	Duracell MN1500	-20 to 45° C	
	Energizer E91	-20 to 50° C	Class I, Division 1, Grp C, D T3B
	Energizer EN91		Class I, Division 1, Grp C, D T3A
	Duracell MN1500		Class I, Division 1, Grp C, D T3C

4 x AA: **200 hours, typical**

*2 installed modules, 1 reading per 5 minute recording interval, and 23° C ambient temperature.

Ultra Low Power: **Up to 60 days, typical***

Uses 4 alkaline AA (LR6) batteries. Use of backlight reduces operating time.

For hazardous location product warnings, refer to the operation manual.

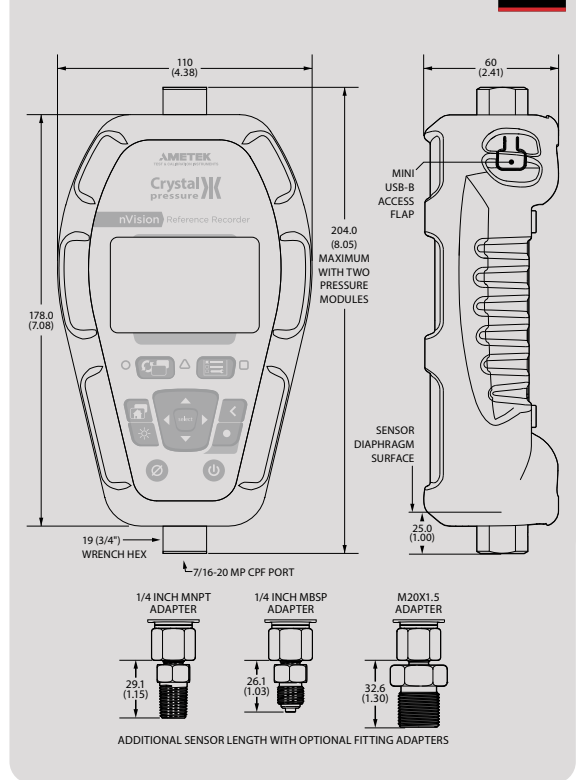

DATA/COMMUNICATION

Digital Interface: **mini-USB**

The mini USB will power the nVision with or without the battery pack installed.

For hazardous location product warnings, refer to the operation manual.

DATALOGGING

Capacity: **Approx. 1,000,000 data points***

**Single Module Recording*

Storage Type: **Non-volatile flash memory**

Limit of 64 individual recordings.

Fastest Interval: **10 per second**

The included CrystalControl software is compatible with Vista (SP 2), Windows 7 (SP 1), Windows 8.1 and Windows 10.

Slowest Interval: **1 per hour**

Produces csv, xls, pdf, or signed pdf files, and uses Excel template files (samples included) to automatically format and graph data.

ENCLOSURE

Weight: **680 g (24.0 oz)**

Weight includes one pressure module, one RTD module, 4AA battery module, and protective boot.

Rating: **IP66 and IP67**

Submersible to 1 m for 30 minutes [IEC 60529].

Housing: **Impact resistant injection molded**

LCD protected from impact damage by 1.5 mm (0.06") thick polycarbonate lens.

Keypad and Labels: **UV Resistant Polyester**

Mounting: **M4 x 0.7 [8 mm (0.31")]** deep threaded insert mounting locations

Skydrol® compatible.

For hazardous location product warnings, refer to the operation manual.

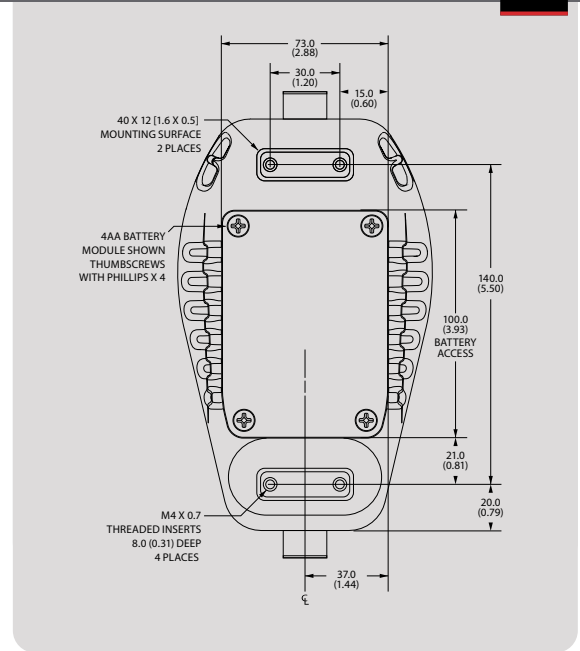

STORAGE TEMPERATURE

Temperature Range: **-40 to 75° C (-40 to 167° F)**

Batteries should be removed if stored for more than one month.

SPECIAL FEATURES

The following requires the use of our free **CrystalControl** software

Averaging Screen: **Averages all points in a recording run.**

Data Point Counter: **Screen for counting the data points logged.**

Display Screens: **Turn on and rearrange display screens.**

Estimated Recording Time: **A CrystalControl calculation based on active screens and logging interval.**

Live PC Graph: **During a recording, graph directly to your PC.**

Password Protect: **Changes to configuration or userspan calibration factor(s).**

Pressure Switch Test: **Using a PM and MA20, get deadband and state-change pressure.**

Remove: **Unwanted pressure units.**

Run Tags: **Create and enable run tags that will identify logging runs.**

Screen Numbers: **Number each display screen to make writing procedures around the nVision easier.**

Secure Documents: **Download into secure pdf documents for tamper proof records.**

Start-up Screen: **Define a 32-character prompt which requires user acknowledgement at startup.**

User Defined Unit: **Define and display any pressure units not included, or to use the gauge to display force, level or other pressure related parameters.**

STANDARD DELIVERY

- nVision Recorder
- CD Manual
- ISO 17025 Accredited Calibration Certificate, NIST Traceable
- Soft Carrying Case **P/N 5535**
- Protective Boot **P/N 3985**
- Mini-USB Cable **P/N 3951**

COMPLEMENTARY PRODUCTS

Crystal Engineering offers a wide range of products that work with the nVision:

- [Fittings that connect without tools, safely and without leaks](#)
- [Lightweight, super flexible high pressure hoses](#)
- [Fitting kits and adapters](#)
- [Pneumatic hand pumps](#)
- [Hydraulic hand pumps](#)
- [Portable pressure comparators](#)
- [Software, for the quickest way to calibrate pressure transmitters and gauges](#)

CERTIFICATIONS



**II 1G Ex ia IIB T4 Ga or T3
SIRA 09 ATEX 2008X**



**Ex ia IIB T4 Ga or T3
IECEX SIR 09.0053X**



Exia Intrinsically Safe and Non-incendive for Hazardous Locations: Class I, Division 1, Groups C and D, Temperature Code T4/T3A/TCB/T3C. For hazardous location product warnings, refer to the operation manual.



nVision complies with the Electromagnetic Compatibility and the Pressure Equipment Directives.



nVision complies with the Australian Radiocommunications (Electromagnetic Compatibility) Standard 2008.



nVision is approved for use as a portable test instrument for Marine use and complies with Det Norske Veritas' Rules for Classification of Ships, High Speed & Light Craft and Offshore Standards.

ACCESSORIES

BARO Calibration Kit P/N 4547

Magnetic Hanging Strap P/N 5177

Waterproof Carrying Case P/N 2888

RTD Terminal Block P/N 3953 (included with RTD100 module)

Test Lead Kit P/N 3952 (included with MA20 Module)

RANGE & RESOLUTION TABLE

PM	Range (psi)	Over-pressure	Display Resolution									
			psi	in H ₂ O	in Hg	mm Hg	mm H ₂ O	kg/cm ²	bar	mbar	kPa	MPa
30PSI	30	3.0 x	0.001	0.01	0.001	0.01	1	0.0001	0.0001	0.1	0.01	
100PSI	100	2.0 x	0.001	0.1	0.01	0.1	1	0.0001	0.0001	0.1	0.01	0.00001
300PSI	300	2.0 x	0.01	0.1	0.01	0.1		0.001	0.001	1	0.1	0.0001
1KPSI	1000	2.0 x	0.1		0.1			0.001	0.001		0.1	0.0001
3KPSI	3000	1.5 x	0.1		0.1			0.01	0.01		1	0.001
10KPSI	10000	1.5 x	1					0.01	0.01		1	0.001
15KPSI	15000	1.3 x	1					0.01	0.01		1	0.001

(Add one digit of resolution for differential mode.)

ORDERING INFORMATION

Model	Power	Upper Module	Lower Module	BARO Module	Pump System*	Carrying Case~
NV	4AA					
Pressure:		PM	PM	No ... (omit)	No Pump... (omit)	
Current, Voltage, and Switch:		MA20	MA20	Yes... BARO	System A... -AXX	Aluminum ... (omit)
Temperature:		RTD100	RTD100		System A... -AHX	Waterproof... -W
Blank Plate:		BNKPLT	BNKPLT		System B... -BXX	
					System B... -BHX	
					System C... -CXX	
					System C... -CHX	
					System D... -DXX	
					System D... -DWX	
					System E... -EOX	
					System F... -FOV	
					System F... -FVW	
					System G... -GOX	
					System G... -GWX	
					System H... -HOX	

If ordering an nVision with only one module installed, enter **BNKPLT** in the empty module slot.

SAMPLE PART NUMBERS

NV-4AA-30PSI-3KPSI-BARO nVision with 30 psi pressure module (upper) and 3000 psi pressure module (lower) and a BARO module option.

NV-4AA-RTD100-10KPSI-GWX-W nVision with RTD100 temperature module (upper) and 10 000 psi pressure module (lower); a System G pump system; and a waterproof carrying case.

AMETEK offers a variety of solutions for pressure generation and measurement. Our line of products for pressure generation includes everything from small pneumatic hand pumps to a precision, hydraulic pressure comparator capable of generating up to 15 000 psi / 1000 bar / 100 MPa.

All of our pumps may be ordered as part of a Pump System, complete with an nVision and delivered in a sturdy carrying case with custom insert.

* Refer to the following page for a more detailed description of each pump system.

~ The Waterproof Case is an option for Systems A, B, and C only.
The Waterproof Case is the only option for Systems G and H.















► Ordering a Pump System Only

Any pump system, carrying case, and connection fittings for an nVision reference recorder may be ordered separately from the gauge. Enter NV-NONE followed by the Pump System part number and the Carrying Case option code.

SAMPLE PART NUMBERS

NV-NONE-GWX-W System G pump system with a waterproof carrying case.

PUMP SYSTEMS OVERVIEW

Pump System	Part Number	Pressure Range	Pneumatic	Hydraulic	Hand Pump	Bench Top	Included Pump	Case Options	
								Aluminum	Waterproof (Pelican Case)
System A	AXX	0 to 30psi /2 bar	■		■		 T-960-CPF	■	■
	AHX	0 to 580 psi /40 bar	■		■		 T-970-CPF	■	■
System B	BXX	-25 inHg to 30 psi /-0.85 to 2 bar	■		■		 T-965-CPF	■	■
	BHX	-27 inHg to 580 psi /-0.91 to 40 bar	■		■		 T-975-CPF	■	■
System C	CXX	0 to 3000 psi /200 bar		■ (Oil)	■		 T-620-CPF	■	■
	CHX	0 to 5000 psi /350 bar		■ (Oil)	■		 T-620H-CPF	■	■
System D	DOX	0 to 5000 psi /350 bar		■ (Oil)		■	 P-018-CPF	■	
	DWX	0 to 5000 psi /350 bar		■ (Water)		■	 P-014-CPF	■	
System E	EOX	0 to 10 000 psi /700 bar		■ (Oil)		■	 T-1-CPF	■	
System F	FOV	0 to 15 000 psi /1000 bar		■ (Oil)		■	 GaugeCalHP		■
	FWV	0 to 15 000 psi /1000 bar		■ (Water)		■	 T-975-CPF	■	
System G	GOX	0 to 15 000 psi /1000 bar		■ (Oil)		■	 T-620H-CPF		■
	GWX	0 to 15 000 psi /1000 bar		■ (Water)		■	 T-975-CPF		■
System H	HOX	-27 inHg to 580 psi /-0.91 to 40 bar	■		■		 T-975-CPF		■
		0 to 5000 psi /350 bar		■ (Oil)	■		 T-620H-CPF		■

Pressure Module (PM)

ACCURACY

MPa (Gauge Pressure)

300 kPa, 1 MPa, and 3 MPa modules

0 to 30% of Range: $\pm (0.0075\% \text{ of Full Scale})$

30 to 110% of Range: $\pm (0.025\% \text{ of Reading})$

Vacuum: For 300 kPa and 1 MPa

$\pm (0.06\% \text{ of Full Scale}^*)$

For 3 MPa

$\pm (0.06\% \text{ of Full Scale}^*) \pm 1 \text{ LSD}$

* Full Scale = -99.9 kPa

10, 30, 70, and 100 MPa modules

0 to 30% of Range: $\pm (0.015\% \text{ of Full Scale})$

30 to 110% of Range: $\pm (0.05\% \text{ of Reading})$

Includes all effects of linearity, hysteresis, repeatability, temperature, and stability for one year.

All models indicate vacuum, but vacuum specification applies to 300 kPa, 1 MPa, and 3 MPa models only.

Not recommended for continuous use at high vacuum.

Refer to [XP2i-DP data sheet](#) for gauges that are intended for continuous high vacuum use.

MPaA (Pressure with BARO module)

300 kPa module

1.38 to 100.00 kPaA: $\pm 0.08 \text{ kPaA}$

100.00 to 400.00 kPaA: $\pm (0.025\% \text{ of Reading})$
 $+ 0.03 \text{ kPaA}$

1 MPa module

0.00138 to 0.10000 MPaA: $\pm 0.00008 \text{ MPaA}$

0.10000 to 0.40000 MPaA: $\pm 0.00010 \text{ MPaA}$

0.40000 to 1.10000 MPaA: $\pm (0.025\% \text{ of Reading})$

3 MPa module

0.0014 to 0.1000 MPaA: $\pm 0.0001 \text{ MPaA}$

0.1000 to 1.000 MPaA: $\pm 0.0003 \text{ MPaA}$

1.000 to 3.1000 MPaA: $\pm (0.025\% \text{ of Reading})$

10 MPa module

0.1000 to 3.1000 MPaA: $\pm 0.0015 \text{ MPaA}$

3.1000 to 10.1000 MPaA: $\pm (0.05\% \text{ of Reading})$

30 MPa module

0.100 to 9.100 MPaA: $\pm 0.005 \text{ MPaA}$

9.100 to 30.100 MPaA: $\pm (0.05\% \text{ of Reading})$

70 MPa module

0.100 to 21.100 MPaA: $\pm 0.011 \text{ MPaA}$

21.100 to 70.100 MPaA: $\pm (0.05\% \text{ of Reading})$

100 MPa module

0.100 to 30.100 MPaA: $\pm 0.015 \text{ MPaA}$

30.100 to 100.100 MPaA: $\pm (0.05\% \text{ of Reading})$

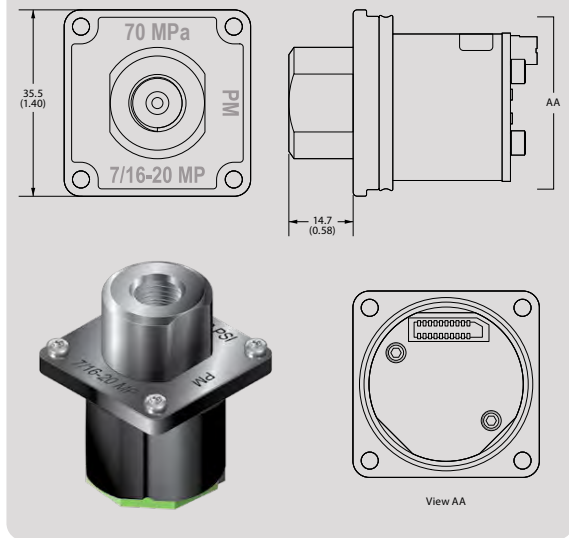

DIFFERENTIAL PRESSURE MEASUREMENT UNCERTAINTIES WITH TARE

The Tare function can improve measurement uncertainties on two modules with the same full scale pressure range installed into one nVision Reference Recorder. Requires the use of an equalizing valve.

The following specifications apply to the measurement system with a logging interval of 1 second/reading:

Full Scale Range of Both Sensors MPa	The Greater of (+/-)				or	% of DP Reading
	mbar	psi	inH ₂ O	mmH ₂ O		
300 (kPa)	0.04	0.0005	0.014	0.4	or	0.025%
1	0.10	0.0015	0.04	1.0	or	0.025%
3	0.4	0.005	0.14	4.0	or	0.025%
10	1.0	0.02	0.4	10.0	or	0.05%
30	4.0	0.05	1.4	n/a	or	0.05%
70	10.0	0.2	4.0	n/a	or	0.05%
100	15.0	0.3	6.0	n/a	or	0.05%

Unit must be enabled in CrystalControl

DIFFERENTIAL PRESSURE MEASUREMENT UNCERTAINTIES WITHOUT TARE

The total nVision Reference Calibrator measurement uncertainty in the ΔP mode configuration will need to consider the uncertainties of both pressure modules. We recommend the module uncertainties to be combined with the preferred square root of the sum of the squares (or "root sum squares") method.

The following table lists the possible combinations of using Pressure Modules (PM) with different accuracy statements. The uncertainties reported below are without the use of the Tare feature, which will greatly improve your measurement uncertainty.

Lower Pressure Module Uncertainties (of Static Line Pressure) (of Reading)		Upper Pressure Module Uncertainties (of Static Line Pressure) (of Reading)	
		0.025%	0.05%
0.025%	0.035%	0.056%	
0.05%	0.056%	0.071%	

SENSOR

Wetted Materials: (WRENCH TIGHT) **316 stainless steel**
(FINGER TIGHT) **316 stainless steel**
and Viton® (internal o-ring)

Diaphragm Seal Fluid: **Silicone Oil**

Connection: **Crystal CPF* Female**

All welded, with a permanently filled diaphragm seal.
Metal to metal cone seal; O-ring can be removed if necessary.
1/4" medium pressure tube system compatible with HIP LMA and LF4 Series, Autoclave Engr SF250CX Male and Female Series.
CPF Adapters to NPT, BSP, and M20 available.
* U.S. Patent No. 8,794,677

BAROMETRIC REFERENCE (BARO)

Accuracy: **± 0.5 mbar, ± 0.00725 psi**

Range: **700.0 to 1100.0 mbarA,**
10.153 to 15.954 psiA

Units and Resolution: **mbar** **0.1**
psi **0.001**
inHg **0.001**
mmHg **0.01**

Pressure Connection: **Cylindrical sensor fitting of 5.8mm OD. A flexible 4.8 mm [3/16"] ID tube is recommended to connect for calibration.**

Mounting: **Secured using a 3/8" 4-40 plastic screw.**

Includes all effects of linearity, hysteresis, repeatability, temperature, and stability for one year.
Exposure to environmental extremes of temperature, shock, and/or vibration may warrant a more frequent recertification period.
Other units available depending on the installed modules.
Plastic non-conductive screw must be used to comply with hazardous location requirements.



Current, Voltage, & Switch Test Module (MA20)

Intended for use with a 4-20mA loop measurement. This module is also capable of measuring supply voltages and has an auxiliary fixed output for use in switch open/closure testing. Each MA20 module includes a super flexible silicone test lead kit (P/N 3952).

CURRENT & VOLTAGE MEASUREMENT

Current (mA) Input

- Accuracy: $\pm (0.015\% \text{ of rdg} + 0.002 \text{ mA})$
- Range: **0 to 55 mA (MA20)**
- Max Allowable Current: **93.3 mA**
- Resolution: **0.001 mA or 0.01%**
- Units: **mA, % 4-20, % 10-50**
- Input Resistance: **< 17.2 Ω**
- Voltage Burden @ 20mA: **< 0.35 V**
- Voltage Burden @ 50mA: **< 0.86 V**
- HART Resistance: **250 Ω**
- Connection: **2mm jacks**

Includes all effects of linearity, hysteresis, repeatability, temperature, and stability for one year.

For hazardous location product warnings, refer to the operation manual.

Inputs protected by a resettable fuse.

mA can be displayed as a percentage, where 0 to 100% corresponds to either 4 to 20 mA or 10 to 50 mA.

Jacks are compatible with safety sheathed banana plugs.

Voltage (VDC) Input

- Accuracy: $\pm (0.015\% \text{ of rdg} + 0.002 \text{ VDC})$
- Range: **0 to 28 VDC**
- Max Allowable Voltage: **30 VDC**
- Resolution: **0.001 VDC**
- Units: **VDC**

Includes all effects of linearity, hysteresis, repeatability, temperature, and stability for one year.

Switch Test

- Switch Type: **Dry Contact**
- Closed State Resistance: **< 10 Ω**
- Open State Resistance: **> 10 M Ω**

Switch state change indicated by bright green LED flash.

Switch test screen reports switch open, close, and deadband values.

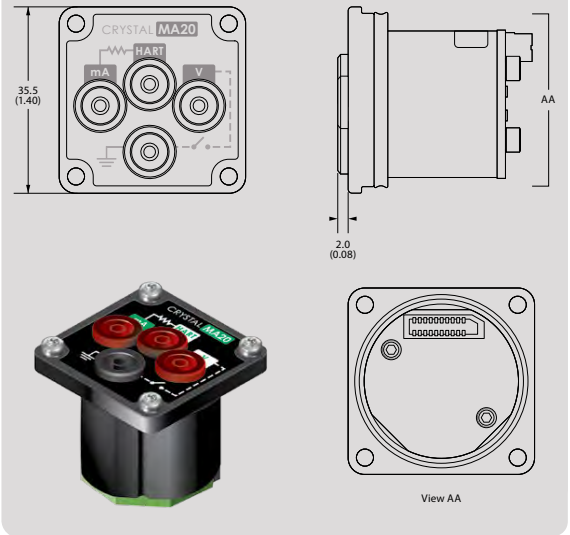

ATEX IEC IECEx ATEX and IECEx Scheme Entity Parameters

The MA20 Module has these specific input entity parameters:

- Ui = 28 V**
- li = 93.3 mA**
- Pi = 653.3 mW**
- Ci = 0.36 uF**
- Li = 39.1 uH**
- Uo = 6.6 V**
- Io = 4.45 mA**
- Po = 7.34 mW**
- Co = 0.5 uF***
- Lo = 12 uH****

* Dependent on the supply to the terminals but shall not be greater than 0.5 uF
 ** Total cable inductance between all modules

Temperature Module (RTD100)

Calibrated for Pt100 RTD/PRT (100 Ohms at 0°C Platinum Resistance Temperature Detector) sensors conforming to DIN/IEC 60751 (or IEC751) with US, Euro, or Lab calibration curves. An RTD is not included, but each RTD100 includes P/N 3953 RTD Connection Kit.

TEMPERATURE MEASUREMENT

Resistance Input

Accuracy: $\pm (0.015\% \text{ of rdg} + 0.02 \Omega)$

Range: **0 – 400 Ohms range for use with 100 Ohm PRTs**

Resolution: **0.01 on all scales**

Units: **°C, K, °F, R, Ω**

TCRs: **0.003850 $\Omega/\Omega/^\circ\text{C}$ (IEC 60751), 0.003911 $\Omega/\Omega/^\circ\text{C}$ (US Industrial Std), 0.003926 $\Omega/\Omega/^\circ\text{C}$**

Wiring: **2-, 3-, 4-wire support**

Connection: **M8 connector cable or terminal block**

Includes all effects of linearity, hysteresis, repeatability, temperature, and stability for one year.

The proper selection of the RTD sensing element is very important as the error associated with this device is the majority of the overall system measurement uncertainty. IEC 751 is the standard that defines the temperature versus resistance for 100 Ω , 0.00385 $\Omega/\Omega/^\circ\text{C}$ platinum RTDs. IEC 751 defines two classes of RTDs: Class A and B. Class A RTDs operate over the -200 to 630°C range versus -200 to 800°C for the Class B elements. For example, the Class A uncertainty is about half that of the Class B elements as illustrated in the following table.

Temperature °C	nVision Uncertainty		Class A				Class B			
	Class A Uncertainty		nVision + Class A Uncertainty		Class B Uncertainty		nVision + Class B Uncertainty			
	$\pm\Omega$	$\pm^\circ\text{C}$	$\pm\Omega$	$\pm^\circ\text{C}$	$\pm\Omega$	$\pm^\circ\text{C}$	$\pm\Omega$	$\pm^\circ\text{C}$	$\pm\Omega$	$\pm^\circ\text{C}$
-200	0.02	0.05	0.24	0.55	0.24	0.55	0.56	1.30	0.56	1.30
0	0.04	0.09	0.06	0.15	0.07	0.17	0.12	0.30	0.12	0.31
200	0.05	0.13	0.2	0.55	0.21	0.56	0.48	1.30	0.48	1.31
400	0.06	0.17	0.33	0.95	0.33	0.96	0.79	2.30	0.79	2.31
600	0.07	0.21	0.43	1.35	0.44	1.37	1.06	3.30	1.06	3.31
800	0.08	0.25	0.52	1.75	0.53	1.77	1.28	4.30	1.28	4.31

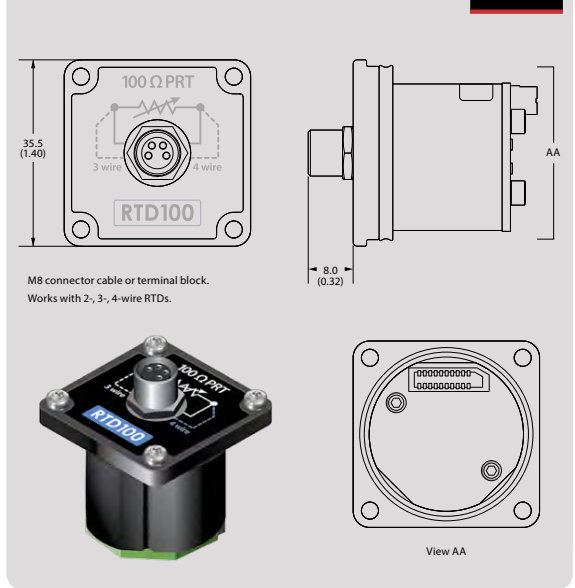

M8 connector cable or terminal block. Works with 2-, 3-, 4-wire RTDs.

View AA

ATEX IEC IECEx ATEX and IECEx Scheme Entity Parameters

The RTD100 Module has these specific input entity parameters:

- Ui = 0 V**
- li = 0 A**
- Pi = 0 W**
- Uo = 9.73 V**
- Io = 1.6642 A**
- Po = 1.1 W**
- Co = 0.5 uF**
- Lo = 12 uH***

* Total cable inductance between all modules

nVision Chassis (NV)

OPERATING TEMPERATURE

Temperature Range: **-20 to 50° C (-4 to 122° F)**

< 95% RH, non-condensing. No change in accuracy over operating temperature range. Gauge must be zeroed to achieve rated specification.

Applies to all modules.

DISPLAY

Screen: **255 x 160 pixel graphical display**

LCD readable in sunlight with bright backlight.

Display Rate: **4 readings/second (standard)**

up to 10 readings/second (recording)

POWER

The nVision is Intrinsically Safe only if powered by one of the following battery types.

ATEX/IECEx:	Approved Battery Type	Ta=	Marking
	Rayovac Max Plus 815	-20 to 50° C	Ex ia IIB T4 Ga
	Duracell MN1500	-20 to 45° C	
	Energizer E91, EN91	-20 to 50° C	Ex ia IIB T3 Ga
	Duracell MN1500		

CSA:	Approved Battery Type	Ta=	Marking
	Rayovac Max Plus 815	-20 to 50° C	Class I, Division 1, Grp C, D T4
	Duracell MN1500	-20 to 45° C	
	Energizer E91	-20 to 50° C	Class I, Division 1, Grp C, D T3B
	Energizer EN91		Class I, Division 1, Grp C, D T3A
	Duracell MN1500		Class I, Division 1, Grp C, D T3C

4 x AA: **200 hours, typical**

*2 installed modules, 1 reading per 5 minute recording interval, and 23° C ambient temperature.

Ultra Low Power: **Up to 60 days, typical***

Uses 4 alkaline AA (LR6) batteries. Use of backlight reduces operating time.

For hazardous location product warnings, refer to the operation manual.

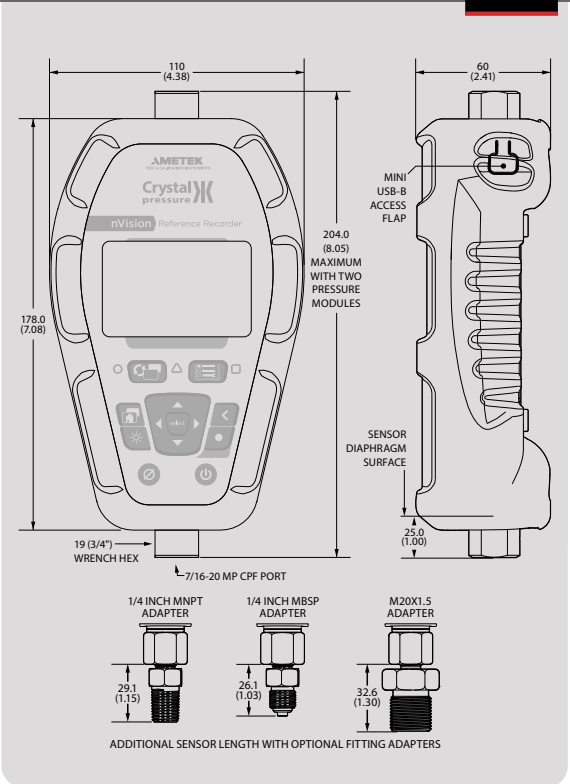

DATA/COMMUNICATION

Digital Interface: **mini-USB**

The mini USB will power the nVision with or without the battery pack installed.

For hazardous location product warnings, refer to the operation manual.

DATALOGGING

Capacity: **Approx. 1,000,000 data points***

**Single Module Recording*

Storage Type: **Non-volatile flash memory**

Limit of 64 individual recordings.

Fastest Interval: **10 per second**

The included CrystalControl software is compatible with Vista (SP 2), Windows 7 (SP 1), Windows 8.1 and Windows 10.

Slowest Interval: **1 per hour**

Produces csv, xls, pdf, or signed pdf files, and uses Excel template files (samples included) to automatically format and graph data.

ENCLOSURE

Weight: **680 g (24.0 oz)**

Weight includes one pressure module, one RTD module, 4AA battery module, and protective boot.

Rating: **IP66 and IP67**

Submersible to 1 m for 30 minutes [IEC 60529].

Housing: **Impact resistant injection molded**

LCD protected from impact damage by 1.5 mm (0.06") thick polycarbonate lens.

Keypad and Labels: **UV Resistant Polyester**

Mounting: **M4 x 0.7 [8 mm (0.31")]** deep threaded insert mounting locations

Skydrol® compatible.

For hazardous location product warnings, refer to the operation manual.

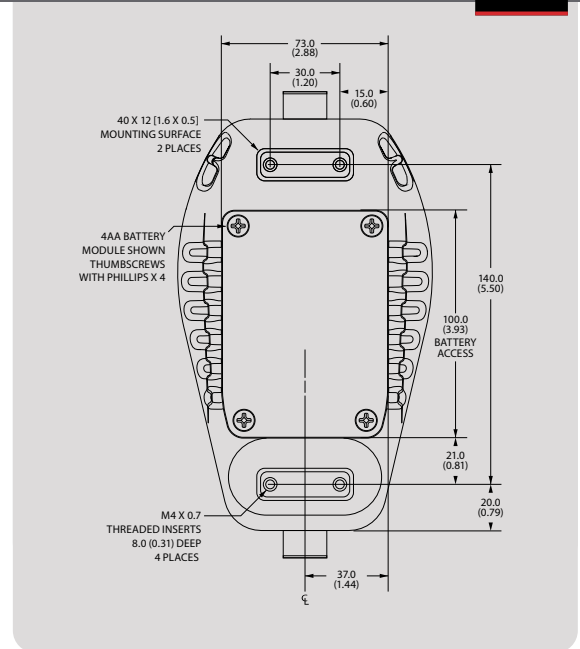

STORAGE TEMPERATURE

Temperature Range: **-40 to 75° C (-40 to 167° F)**

Batteries should be removed if stored for more than one month.

SPECIAL FEATURES

The following requires the use of our free **CrystalControl** software

Averaging Screen: **Averages all points in a recording run.**

Data Point Counter: **Screen for counting the data points logged.**

Display Screens: **Turn on and rearrange display screens.**

Estimated Recording Time: **A CrystalControl calculation based on active screens and logging interval.**

Live PC Graph: **During a recording, graph directly to your PC.**

Password Protect: **Changes to configuration or userspan calibration factor(s).**

Pressure Switch Test: **Using a PM and MA20, get deadband and state-change pressure.**

Remove: **Unwanted pressure units.**

Run Tags: **Create and enable run tags that will identify logging runs.**

Screen Numbers: **Number each display screen to make writing procedures around the nVision easier.**

Secure Documents: **Download into secure pdf documents for tamper proof records.**

Start-up Screen: **Define a 32-character prompt which requires user acknowledgement at startup.**

User Defined Unit: **Define and display any pressure units not included, or to use the gauge to display force, level or other pressure related parameters.**

STANDARD DELIVERY

- nVision Recorder
- CD Manual
- ISO 17025 Accredited Calibration Certificate, NIST Traceable
- Soft Carrying Case **P/N 5535**
- Protective Boot **P/N 3985**
- Mini-USB Cable **P/N 3951**

COMPLEMENTARY PRODUCTS

Crystal Engineering offers a wide range of products that work with the nVision:

- [Fittings that connect without tools, safely and without leaks](#)
- [Lightweight, super flexible high pressure hoses](#)
- [Fitting kits and adapters](#)
- [Pneumatic hand pumps](#)
- [Hydraulic hand pumps](#)
- [Portable pressure comparators](#)
- [Software, for the quickest way to calibrate pressure transmitters and gauges](#)

CERTIFICATIONS



**II 1G Ex ia IIB T4 Ga or T3
SIRA 09 ATEX 2008X**



**Ex ia IIB T4 Ga or T3
IECEX SIR 09.0053X**



Exia Intrinsically Safe and Non-incendive for Hazardous Locations: Class I, Division 1, Groups C and D, Temperature Code T4/T3A/TCB/T3C. For hazardous location product warnings, refer to the operation manual.



nVision complies with the Electromagnetic Compatibility and the Pressure Equipment Directives.



nVision complies with the Australian Radiocommunications (Electromagnetic Compatibility) Standard 2008.



nVision is approved for use as a portable test instrument for Marine use and complies with Det Norske Veritas' Rules for Classification of Ships, High Speed & Light Craft and Offshore Standards.

ACCESSORIES

BARO Calibration Kit P/N 4547

Magnetic Hanging Strap P/N 5177

Waterproof Carrying Case P/N 2888

RTD Terminal Block P/N 3953 (included with RTD100 module)

Test Lead Kit P/N 3952 (included with MA20 Module)

RANGE & RESOLUTION TABLE

PM	Range (MPa)	Over-pressure	Display Resolution			
			MPa	kPa	bar	mbar
300KPA	300(kPa)	3.0 x		0.01	0.0001	0.1
1MPa	1	2.0 x	0.00001	0.01	0.0001	0.1
3MPa	3	2.0 x	0.0001	0.1	0.001	1
10MPa	10	2.0 x	0.0001	0.1	0.001	
30MPa	30	1.5 x	0.001	1	0.01	
70MPa	70	1.5 x	0.001	1	0.01	
100MPa	100	1.3 x	0.001	1	0.01	

(Add one digit of resolution for differential mode.)

ORDERING INFORMATION*

Model	Power	Upper Module	Lower Module	BARO Module
NV	4AA			
Pressure:		PM	PM	No ... (omit)
Current, Voltage, and Switch:		MA20	MA20	Yes... BARO
Temperature:		RTD100	RTD100	
Blank Plate:		BNKPLT	BNKPLT	

If ordering an nVision with only one module installed, enter **BNKPLT** in the empty module slot.

SAMPLE PART NUMBERS

NV-4AA-**300KPA**-**30MPa**-**BARO** ... nVision with 300 kPa pressure module (upper) and 30 MPa pressure module (lower); and a BARO module option.

NV-4AA-**RTD100**-**70MPa**-**GWX-W** ... nVision with RTD100 temperature module (upper) and 70 MPa pressure module (lower); a System G pump system; and a waterproof carrying case.

Pump System*	Carrying Case~
No Pump.... (omit)	
System A.... -AXX	Aluminum ... (omit)
System A.... -AHX	Waterproof..... -W
System B.... -BXX	
System B.... -BHX	
System C.... -CXX	
System C.... -CHX	
System D.... -DXX	
System D.... -DWX	
System E.... -EOX	
System F.... -FOV	
System F.... -FVW	
System G.... -GOX	
System G.... -GWX	
System H.... -HOX	

~ The Waterproof Case is an option for Systems A, B, and C only.
* The Waterproof Case is the only option for Systems G and H.

AMETEK offers a variety of solutions for pressure generation and measurement. Our line of products for pressure generation includes everything from small pneumatic hand pumps to a precision, hydraulic pressure comparator capable of generating up to 15 000 psi / 1000 bar / 100 MPa.

All of our pumps may be ordered as part of a Pump System, complete with an nVision and delivered in a sturdy carrying case with custom insert.

* Refer to the following page for a more detailed description of each pump system.

► Ordering a Pump System Only















Any pump system, carrying case, and connection fittings for an nVision reference recorder may be ordered separately from the gauge. Enter NV-NONE followed by the Pump System part number and the Carrying Case option code.

SAMPLE PART NUMBERS

NV-NONE-GWX-W ... System G pump system with a waterproof carrying case.

*MPa versions available in USA direct from factory only.

PUMP SYSTEMS OVERVIEW

Pump System	Part Number	Pressure Range	Pneumatic	Hydraulic	Hand Pump	Bench Top	Included Pump	Case Options	
								Aluminum	Waterproof (Pelican Case)
System A	AXX	0 to 30psi /2 bar	■		■		 T-960-CPF	■	■
	AHX	0 to 580 psi /40 bar	■		■		 T-970-CPF	■	■
System B	BXX	-25 inHg to 30 psi /-0.85 to 2 bar	■		■		 T-965-CPF	■	■
	BHX	-27 inHg to 580 psi /-0.91 to 40 bar	■		■		 T-975-CPF	■	■
System C	CXX	0 to 3000 psi /200 bar		■ (Oil)	■		 T-620-CPF	■	■
	CHX	0 to 5000 psi /350 bar		■ (Oil)	■		 T-620H-CPF	■	■
System D	DOX	0 to 5000 psi /350 bar		■ (Oil)		■	 P-018-CPF	■	
	DWX	0 to 5000 psi /350 bar		■ (Water)		■	 P-014-CPF	■	
System E	EOX	0 to 10 000 psi /700 bar		■ (Oil)		■	 T-1-CPF	■	
System F	FOV	0 to 15 000 psi /1000 bar		■ (Oil)		■	 GaugeCalHP		■
	FWV	0 to 15 000 psi /1000 bar		■ (Water)		■	 T-975-CPF	■	
System G	GOX	0 to 15 000 psi /1000 bar		■ (Oil)		■	 T-620H-CPF		■
	GWX	0 to 15 000 psi /1000 bar		■ (Water)		■	 T-975-CPF		■
System H	HOX	-27 inHg to 580 psi /-0.91 to 40 bar	■		■		 T-975-CPF		■
		0 to 5000 psi /350 bar		■ (Oil)	■		 T-620H-CPF		■

Pressure Module (PM)

ACCURACY

kg/cm² (Gauge Pressure)

3, 10, and 30 kg/cm² modules
0 to 30% of Range: ± (0.0075% of Full Scale)
30 to 110% of Range: ± (0.025% of Reading)
Vacuum: For 3 and 10 kg/cm ² ± (0.06% of Full Scale*)
For 30 kg/cm ² ± (0.06% of Full Scale*) ±1 LSD
* Full Scale = -1.0 kg/cm ²

100, 300, 700, and 1000 kg/cm² modules
0 to 30% of Range: ± (0.015% of Full Scale)
30 to 110% of Range: ± (0.05% of Reading)

Includes all effects of linearity, hysteresis, repeatability, temperature, and stability for one year.

All models indicate vacuum, but vacuum specification applies to 3, 10, and 30 kg/cm² models only.

Not recommended for continuous use at high vacuum. Refer to [XP2i-DP data sheet](#) for gauges that are intended for continuous high vacuum use.

kg/cm²A (Pressure with BARO module)

3 kg/cm² module
0.0141 to 1.0000 kg/cm ² A: ± 0.0008 kg/cm²A
1.0000 to 4.0000 kg/cm ² A: ± (0.025% of Reading) + 0.0003 kg/cm²A
10 kg/cm² module
0.0141 to 1.0000 kg/cm ² A: ± 0.0008 kg/cm²A
1.0000 to 4.0000 kg/cm ² A: ± 0.0010 kg/cm²A
4.0000 to 11.0000 kg/cm ² A: ± (0.025% of Reading)
30 kg/cm² module
0.014 to 1.000 kg/cm ² A: ±0.001 kg/cm²A
1.000 to 10.000 kg/cm ² A: ± 0.003 kg/cm²A
10.000 to 31.000 kg/cm ² A: ± (0.025% of Reading)
100 kg/cm² module
1.000 to 31.000 kg/cm ² A: ± 0.015 kg/cm²A
31.000 to 101.000 kg/cm ² A: ± (0.05% of Reading)
300 kg/cm² module
1.00 to 91.00 kg/cm ² A: ± 0.05 kg/cm²A
91.00 to 301.00 kg/cm ² A: ± (0.05% of Reading)
700 kg/cm² module
1.00 to 211.00 kg/cm ² A: ± 0.11 kg/cm²A
211.00 to 701.00 kg/cm ² A: ± (0.05% of Reading)
1000 kg/cm² module
1.00 to 301.00 kg/cm ² A: ± 0.15 kg/cm²A
301.00 to 1001.00 kg/cm ² A: ± (0.05% of Reading)

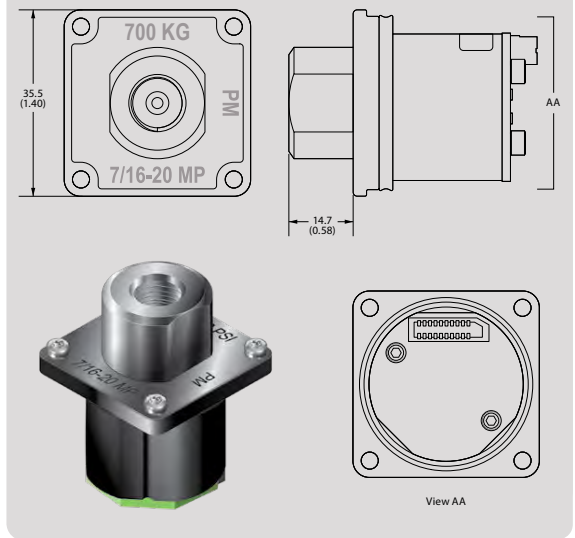

DIFFERENTIAL PRESSURE MEASUREMENT UNCERTAINTIES WITH TARE

The Tare function can improve measurement uncertainties on two modules with the same full scale pressure range installed into one nVision Reference Recorder. Requires the use of an equalizing valve.

The following specifications apply to the measurement system with a logging interval of 1 second/reading:

Full Scale Range of Both Sensors kg/cm ²	The Greater of (+/-)				or	% of DP Reading
	mbar	psi	inH ₂ O	mmH ₂ O		
3	0.04	0.0005	0.014	0.4	or	0.025%
10	0.10	0.0015	0.04	1.0	or	0.025%
30	0.4	0.005	0.14	4.0	or	0.025%
100	1.0	0.02	0.4	10.0	or	0.05%
300	4.0	0.05	1.4	n/a	or	0.05%
700	10.0	0.2	4.0	n/a	or	0.05%
1000	15.0	0.3	6.0	n/a	or	0.05%

Unit must be enabled in CrystalControl

DIFFERENTIAL PRESSURE MEASUREMENT UNCERTAINTIES WITHOUT TARE

The total nVision Reference Calibrator measurement uncertainty in the ΔP mode configuration will need to consider the uncertainties of both pressure modules. We recommend the module uncertainties to be combined with the preferred square root of the sum of the squares (or "root sum squares") method.

The following table lists the possible combinations of using Pressure Modules (PM) with different accuracy statements. The uncertainties reported below are without the use of the Tare feature, which will greatly improve your measurement uncertainty.

Lower Pressure Module Uncertainties (of Static Line Pressure) (of Reading)		Upper Pressure Module Uncertainties (of Static Line Pressure) (of Reading)	
		0.025%	0.05%
0.025%	0.035%	0.056%	
0.05%	0.056%	0.071%	

SENSOR

Wetted Materials: (WRENCH TIGHT) **316 stainless steel**
(FINGER TIGHT) **316 stainless steel**
and Viton® (internal o-ring)

Diaphragm Seal Fluid: **Silicone Oil**

Connection: **Crystal CPF* Female**

All welded, with a permanently filled diaphragm seal.
Metal to metal cone seal; O-ring can be removed if necessary.
1/4" medium pressure tube system compatible with HIP LMA and LF4 Series, Autoclave Engr SF250CX Male and Female Series.
CPF Adapters to NPT, BSP, and M20 available.
** U.S. Patent No. 8,794,677*

BAROMETRIC REFERENCE (BARO)

Accuracy: **± 0.5 mbar, ± 0.00725 psi**

Range: **700.0 to 1100.0 mbarA,**
10.153 to 15.954 psiA

Units and Resolution: **mbar** **0.1**
psi **0.001**
inHg **0.001**
mmHg **0.01**

Pressure Connection: **Cylindrical sensor fitting of 5.8mm OD. A flexible 4.8 mm [3/16"] ID tube is recommended to connect for calibration.**

Mounting: **Secured using a 3/8" 4-40 plastic screw.**

Includes all effects of linearity, hysteresis, repeatability, temperature, and stability for one year.
Exposure to environmental extremes of temperature, shock, and/or vibration may warrant a more frequent recertification period.
Other units available depending on the installed modules.
Plastic non-conductive screw must be used to comply with hazardous location requirements.



Current, Voltage, & Switch Test Module (MA20)

Intended for use with a 4-20mA loop measurement. This module is also capable of measuring supply voltages and has an auxiliary fixed output for use in switch open/closure testing. Each MA20 module includes a super flexible silicone test lead kit (P/N 3952).

CURRENT & VOLTAGE MEASUREMENT

Current (mA) Input

- Accuracy: $\pm (0.015\% \text{ of rdg} + 0.002 \text{ mA})$
- Range: **0 to 55 mA (MA20)**
- Max Allowable Current: **93.3 mA**
- Resolution: **0.001 mA or 0.01%**
- Units: **mA, % 4-20, % 10-50**
- Input Resistance: **< 17.2 Ω**
- Voltage Burden @ 20mA: **< 0.35 V**
- Voltage Burden @ 50mA: **< 0.86 V**
- HART Resistance: **250 Ω**
- Connection: **2mm jacks**

Includes all effects of linearity, hysteresis, repeatability, temperature, and stability for one year.

For hazardous location product warnings, refer to the operation manual.

Inputs protected by a resettable fuse.

mA can be displayed as a percentage, where 0 to 100% corresponds to either 4 to 20 mA or 10 to 50 mA.

Jacks are compatible with safety sheathed banana plugs.

Voltage (VDC) Input

- Accuracy: $\pm (0.015\% \text{ of rdg} + 0.002 \text{ VDC})$
- Range: **0 to 28 VDC**
- Max Allowable Voltage: **30 VDC**
- Resolution: **0.001 VDC**
- Units: **VDC**

Includes all effects of linearity, hysteresis, repeatability, temperature, and stability for one year.

Switch Test

- Switch Type: **Dry Contact**
- Closed State Resistance: **< 10 Ω**
- Open State Resistance: **> 10 M Ω**

Switch state change indicated by bright green LED flash.

Switch test screen reports switch open, close, and deadband values.

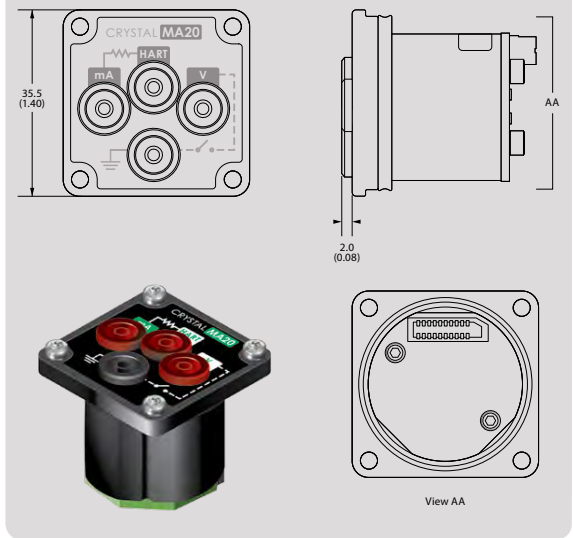

ATEX IEC IECEx ATEX and IECEx Scheme Entity Parameters

The MA20 Module has these specific input entity parameters:

- Ui = 28 V**
- li = 93.3 mA**
- Pi = 653.3 mW**
- Ci = 0.36 uF**
- Li = 39.1 uH**
- Uo = 6.6 V**
- Io = 4.45 mA**
- Po = 7.34 mW**
- Co = 0.5 uF***
- Lo = 12 uH****

* Dependent on the supply to the terminals but shall not be greater than 0.5 uF
 ** Total cable inductance between all modules

Temperature Module (RTD100)

Calibrated for Pt100 RTD/PRT (100 Ohms at 0°C Platinum Resistance Temperature Detector) sensors conforming to DIN/IEC 60751 (or IEC751) with US, Euro, or Lab calibration curves. An RTD is not included, but each RTD100 includes P/N 3953 RTD Connection Kit.

TEMPERATURE MEASUREMENT

Resistance Input

Accuracy: $\pm (0.015\% \text{ of rdg} + 0.02 \Omega)$

Range: **0 – 400 Ohms range for use with 100 Ohm PRTs**

Resolution: **0.01 on all scales**

Units: **°C, K, °F, R, Ω**

TCRs: **0.003850 $\Omega/\Omega/^\circ\text{C}$ (IEC 60751), 0.003911 $\Omega/\Omega/^\circ\text{C}$ (US Industrial Std), 0.003926 $\Omega/\Omega/^\circ\text{C}$**

Wiring: **2-, 3-, 4-wire support**

Connection: **M8 connector cable or terminal block**

Includes all effects of linearity, hysteresis, repeatability, temperature, and stability for one year.

The proper selection of the RTD sensing element is very important as the error associated with this device is the majority of the overall system measurement uncertainty. IEC 751 is the standard that defines the temperature versus resistance for 100 Ω , 0.00385 $\Omega/\Omega/^\circ\text{C}$ platinum RTDs. IEC 751 defines two classes of RTDs: Class A and B. Class A RTDs operate over the -200 to 630°C range versus -200 to 800°C for the Class B elements. For example, the Class A uncertainty is about half that of the Class B elements as illustrated in the following table.

Temperature °C	nVision Uncertainty		Class A				Class B			
	Class A Uncertainty		nVision + Class A Uncertainty		Class B Uncertainty		nVision + Class B Uncertainty			
	$\pm\Omega$	$\pm^\circ\text{C}$	$\pm\Omega$	$\pm^\circ\text{C}$	$\pm\Omega$	$\pm^\circ\text{C}$	$\pm\Omega$	$\pm^\circ\text{C}$		
-200	0.02	0.05	0.24	0.55	0.24	0.55	0.56	1.30	0.56	1.30
0	0.04	0.09	0.06	0.15	0.07	0.17	0.12	0.30	0.12	0.31
200	0.05	0.13	0.2	0.55	0.21	0.56	0.48	1.30	0.48	1.31
400	0.06	0.17	0.33	0.95	0.33	0.96	0.79	2.30	0.79	2.31
600	0.07	0.21	0.43	1.35	0.44	1.37	1.06	3.30	1.06	3.31
800	0.08	0.25	0.52	1.75	0.53	1.77	1.28	4.30	1.28	4.31

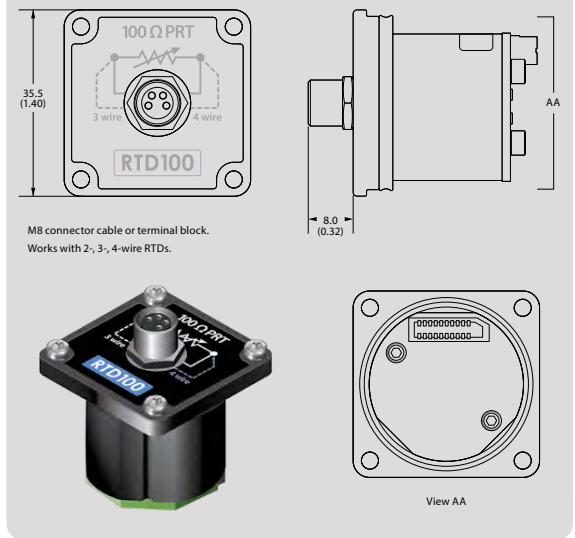

M8 connector cable or terminal block. Works with 2-, 3-, 4-wire RTDs.

View AA

ATEX IEC IECEx ATEX and IECEx Scheme Entity Parameters

The RTD100 Module has these specific input entity parameters:

- Ui = 0 V** **Uo = 9.73 V**
- Ii = 0 A** **Io = 1.6642 A**
- Pi = 0 W** **Po = 1.1 W**
- Co = 0.5 uF**
- Lo = 12 uH***

* Total cable inductance between all modules

nVision Chassis (NV)

OPERATING TEMPERATURE

Temperature Range: **-20 to 50° C (-4 to 122° F)**

< 95% RH, non-condensing. No change in accuracy over operating temperature range. Gauge must be zeroed to achieve rated specification.

Applies to all modules.

DISPLAY

Screen: **255 x 160 pixel graphical display**

LCD readable in sunlight with bright backlight.

Display Rate: **4 readings/second (standard)**

up to 10 readings/second (recording)

POWER

The nVision is Intrinsicly Safe only if powered by one of the following battery types.

ATEX/IECEx:	Approved Battery Type	Ta=	Marking
	Rayovac Max Plus 815	-20 to 50° C	Ex ia IIB T4 Ga
	Duracell MN1500	-20 to 45° C	
	Energizer E91, EN91	-20 to 50° C	Ex ia IIB T3 Ga
	Duracell MN1500		

CSA:	Approved Battery Type	Ta=	Marking
	Rayovac Max Plus 815	-20 to 50° C	Class I, Division 1, Grp C, D T4
	Duracell MN1500	-20 to 45° C	
	Energizer E91	-20 to 50° C	Class I, Division 1, Grp C, D T3B
	Energizer EN91		Class I, Division 1, Grp C, D T3A
	Duracell MN1500		Class I, Division 1, Grp C, D T3C

4 x AA: **200 hours, typical**

Ultra Low Power: **Up to 60 days, typical***

*2 installed modules, 1 reading per 5 minute recording interval, and 23° C ambient temperature.

Uses 4 alkaline AA (LR6) batteries. Use of backlight reduces operating time.

For hazardous location product warnings, refer to the operation manual.

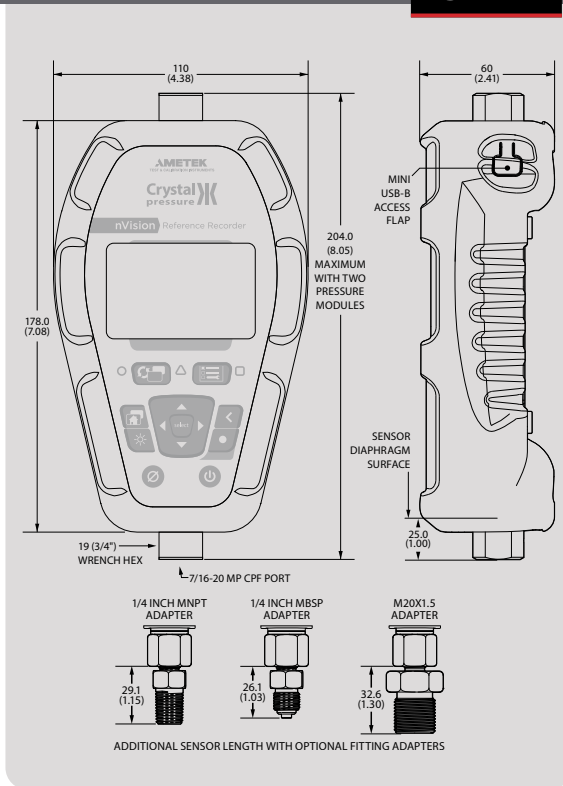

ADDITIONAL SENSOR LENGTH WITH OPTIONAL FITTING ADAPTERS

DATA/COMMUNICATION

Digital Interface: **mini-USB**

The mini USB will power the nVision with or without the battery pack installed.

For hazardous location product warnings, refer to the operation manual.

DATALOGGING

Capacity: **Approx. 1,000,000 data points***

**Single Module Recording*

Storage Type: **Non-volatile flash memory**

Limit of 64 individual recordings.

Fastest Interval: **10 per second**

The included CrystalControl software is compatible with Vista (SP 2), Windows 7 (SP 1), Windows 8.1 and Windows 10.

Slowest Interval: **1 per hour**

Produces csv, xls, pdf, or signed pdf files, and uses Excel template files (samples included) to automatically format and graph data.

ENCLOSURE

Weight: **680 g (24.0 oz)**

Weight includes one pressure module, one RTD module, 4AA battery module, and protective boot.

Rating: **IP66 and IP67**

Submersible to 1 m for 30 minutes [IEC 60529].

Housing: **Impact resistant injection molded**

LCD protected from impact damage by 1.5 mm (0.06") thick polycarbonate lens.

Keypad and Labels: **UV Resistant Polyester**

Mounting: **M4 x 0.7 [8 mm (0.31")]** deep threaded insert mounting locations

Skydrol® compatible.

For hazardous location product warnings, refer to the operation manual.

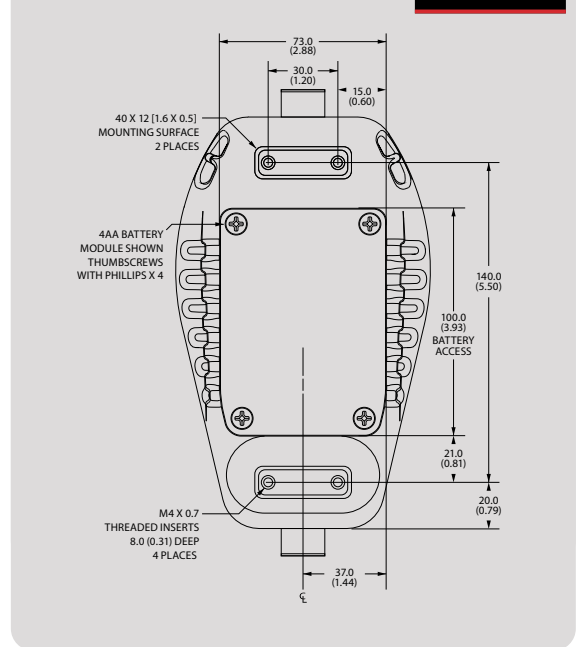

STORAGE TEMPERATURE

Temperature Range: **-40 to 75° C (-40 to 167° F)**

Batteries should be removed if stored for more than one month.

SPECIAL FEATURES

The following requires the use of our free **CrystalControl** software

Averaging Screen: **Averages all points in a recording run.**

Data Point Counter: **Screen for counting the data points logged.**

Display Screens: **Turn on and rearrange display screens.**

Estimated Recording Time: **A CrystalControl calculation based on active screens and logging interval.**

Live PC Graph: **During a recording, graph directly to your PC.**

Password Protect: **Changes to configuration or userspan calibration factor(s).**

Pressure Switch Test: **Using a PM and MA20, get deadband and state-change pressure.**

Remove: **Unwanted pressure units.**

Run Tags: **Create and enable run tags that will identify logging runs.**

Screen Numbers: **Number each display screen to make writing procedures around the nVision easier.**

Secure Documents: **Download into secure pdf documents for tamper proof records.**

Start-up Screen: **Define a 32-character prompt which requires user acknowledgement at startup.**

User Defined Unit: **Define and display any pressure units not included, or to use the gauge to display force, level or other pressure related parameters.**

STANDARD DELIVERY

- nVision Recorder
- CD Manual
- ISO 17025 Accredited Calibration Certificate, NIST Traceable
- Soft Carrying Case **P/N 5535**
- Protective Boot **P/N 3985**
- Mini-USB Cable **P/N 3951**

COMPLEMENTARY PRODUCTS

Crystal Engineering offers a wide range of products that work with the nVision:

- [Fittings that connect without tools, safely and without leaks](#)
- [Lightweight, super flexible high pressure hoses](#)
- [Fitting kits and adapters](#)
- [Pneumatic hand pumps](#)
- [Hydraulic hand pumps](#)
- [Portable pressure comparators](#)
- [Software, for the quickest way to calibrate pressure transmitters and gauges](#)

CERTIFICATIONS



II 1G Ex ia IIB T4 Ga or T3
SIRA 09 ATEX 2008X



Ex ia IIB T4 Ga or T3
IECEX SIR 09.0053X



Exia Intrinsically Safe and Non-incendive for Hazardous Locations: Class I, Division 1, Groups C and D, Temperature Code T4/T3A/TCB/T3C. For hazardous location product warnings, refer to the operation manual.



nVision complies with the Electromagnetic Compatibility and the Pressure Equipment Directives.



nVision complies with the Australian Radiocommunications (Electromagnetic Compatibility) Standard 2008.



nVision is approved for use as a portable test instrument for Marine use and complies with Det Norske Veritas' Rules for Classification of Ships, High Speed & Light Craft and Offshore Standards.

ACCESSORIES

BARO Calibration Kit P/N 4547

Magnetic Hanging Strap P/N 5177

Waterproof Carrying Case P/N 2888

RTD Terminal Block P/N 3953 (included with RTD100 module)

Test Lead Kit P/N 3952 (included with MA20 Module)

RANGE & RESOLUTION TABLE

PM	Range (kg)	Over-pressure	Display Resolution										
			kg/cm ²	bar	mbar	kPa	MPa	psi	in H ₂ O	in Hg	mm Hg	mm H ₂ O	
3KG	3	3.0 x	0.0001	0.0001	0.1	0.01			0.001	0.01	0.001	0.01	1
10KG	10	2.0 x	0.0001	0.0001	0.1	0.01	0.00001	0.001	0.1	0.01	0.1	0.1	1
30KG	30	2.0 x	0.001	0.001	1	0.1	0.0001	0.01	0.1	0.01	0.1		
100KG	100	2.0 x	0.001	0.001		0.1	0.0001	0.1		0.1			
300KG	300	1.5 x	0.01	0.01		1	0.001	0.1		0.1			
700KG	700	1.5 x	0.01	0.01		1	0.001	1					
1000KG	1000	1.3 x	0.01	0.01		1	0.001	1					

(Add one digit of resolution for differential mode.)

ORDERING INFORMATION*

Model	Power	Upper Module	Lower Module	BARO Module	Pump System*	Carrying Case~
NV	4AA					
Pressure:		PM	PM	No ... (omit)	No Pump... (omit)	
Current, Voltage, and Switch:		MA20	MA20	Yes... -BARO	System A... -AXX	Aluminum ... (omit)
Temperature:		RTD100	RTD100		System A... -AHX	Waterproof... -W
Blank Plate:		BNKPLT	BNKPLT		System B... -BXX	
					System B... -BHX	
					System C... -CXX	
					System C... -CHX	
					System D... -DOX	
					System D... -DWX	
					System E... -EOX	
					System F... -FOV	
					System F... -FVW	
					System G... -GOX	
					System G... -GWX	
					System H... -HOX	

If ordering an nVision with only one module installed, enter **BNKPLT** in the empty module slot.

SAMPLE PART NUMBERS

NV-4AA-~~3KG~~-~~300KG~~-~~BARO~~... nVision with 3 kg pressure module (upper) and 300 kg pressure module (lower); and a BARO module option.

NV-4AA-~~RTD100~~-~~700KG~~-~~GWX~~-~~W~~... nVision with RTD100 temperature module (upper) and 700 kg pressure module (lower); a System G pump system; and a waterproof carrying case.

AMETEK offers a variety of solutions for pressure generation and measurement. Our line of products for pressure generation includes everything from small pneumatic hand pumps to a precision, hydraulic pressure comparator capable of generating up to 15 000 psi / 1000 bar / 100 MPa.

All of our pumps may be ordered as part of a Pump System, complete with an nVision and delivered in a sturdy carrying case with custom insert.

* Refer to the following page for a more detailed description of each pump system.

~ The Waterproof Case is an option for Systems A, B, and C only.
The Waterproof Case is the only option for Systems G and H.

► Ordering a Pump System Only















Any pump system, carrying case, and connection fittings for an nVision reference recorder may be ordered separately from the gauge. Enter NV-NONE followed by the Pump System part number and the Carrying Case option code.

SAMPLE PART NUMBERS

NV-NONE-GWX-W... System G pump system with a waterproof carrying case.

*KG versions available in USA direct from factory only.

PUMP SYSTEMS OVERVIEW

Pump System	Part Number	Pressure Range	Pneumatic	Hydraulic	Hand Pump	Bench Top	Included Pump	Case Options	
								Aluminum	Waterproof (Pelican Case)
System A	AXX	0 to 30psi /2 bar	■		■		 T-960-CPF	■	■
	AHX	0 to 580 psi /40 bar	■		■		 T-970-CPF	■	■
System B	BXX	-25 inHg to 30 psi /-0.85 to 2 bar	■		■		 T-965-CPF	■	■
	BHX	-27 inHg to 580 psi /-0.91 to 40 bar	■		■		 T-975-CPF	■	■
System C	CXX	0 to 3000 psi /200 bar		■ (Oil)	■		 T-620-CPF	■	■
	CHX	0 to 5000 psi /350 bar		■ (Oil)	■		 T-620H-CPF	■	■
System D	DOX	0 to 5000 psi /350 bar		■ (Oil)		■	 P-018-CPF	■	
	DWX	0 to 5000 psi /350 bar		■ (Water)		■	 P014-CPF	■	
System E	EOX	0 to 10 000 psi /700 bar		■ (Oil)		■	 T-1-CPF	■	
System F	FOV	0 to 15 000 psi /1000 bar		■ (Oil)		■	 GaugeCalHP		■
	FWV	0 to 15 000 psi /1000 bar		■ (Water)		■	 GaugeCalHP		■
System G	GOX	0 to 15 000 psi /1000 bar		■ (Oil)		■	 T-975-CPF (and) T-620H-CPF		■
	GWX	0 to 15 000 psi /1000 bar		■ (Water)		■	 T-975-CPF (and) T-620H-CPF		■
System H	HOX	-27 inHg to 580 psi /-0.91 to 40 bar	■		■		 T-975-CPF (and) T-620H-CPF		■
		0 to 5000 psi /350 bar		■ (Oil)	■		 T-975-CPF (and) T-620H-CPF		■

Pressure Module (PM)

ACCURACY

bar (Gauge Pressure)

3, 10, and 30 bar modules

0 to 30% of Range: $\pm 0.0075\%$ of Full Scale

30 to 110% of Range: $\pm 0.025\%$ of Reading

Vacuum: For 3 and 10 bar

$\pm 0.06\%$ of Full Scale*

For 30 bar

$\pm 0.06\%$ of Full Scale* ± 1 LSD

* Full Scale = -1.0 bar

100, 300, 700, and 1000 bar

0 to 30% of Range: $\pm 0.015\%$ of Full Scale

30 to 110% of Range: $\pm 0.05\%$ of Reading

Includes all effects of linearity, hysteresis, repeatability, temperature, and stability for one year.

All models indicate vacuum, but vacuum specification applies to 3, 10, and 30 bar models only.

Not recommended for continuous use at high vacuum.

Refer to [XP2i-DP data sheet](#) for gauges that are intended for continuous high vacuum use.

barA (Pressure with BARO module)

3 bar module

0.0138 to 1.0000 barA: ± 0.0008 barA

1.0000 to 4.0000 barA: $\pm 0.025\%$ of Reading
 $+ 0.0003$ barA

10 bar module

0.0138 to 1.0000 barA: ± 0.0008 barA

1.0000 to 4.0000 barA: ± 0.0010 barA
4.0000 to 11.0000 barA: $\pm 0.025\%$ of Reading

30 bar module

0.014 to 1.000 barA: ± 0.001 barA

1.000 to 10.000 barA: ± 0.003 barA
10.000 to 31.000 barA: $\pm 0.025\%$ of Reading

100 bar module

1.000 to 31.000 barA: ± 0.015 barA

31.000 to 101.000 barA: $\pm 0.05\%$ of Reading

300 bar module

1.00 to 91.00 barA: ± 0.05 barA

91.00 to 301.00 barA: $\pm 0.05\%$ of Reading

700 bar module

1.00 to 211.00 barA: ± 0.11 barA

211.00 to 701.00 barA: $\pm 0.05\%$ of Reading

1000 bar module

1.00 to 301.00 barA: ± 0.15 barA

301.00 to 1001.00 barA: $\pm 0.05\%$ of Reading

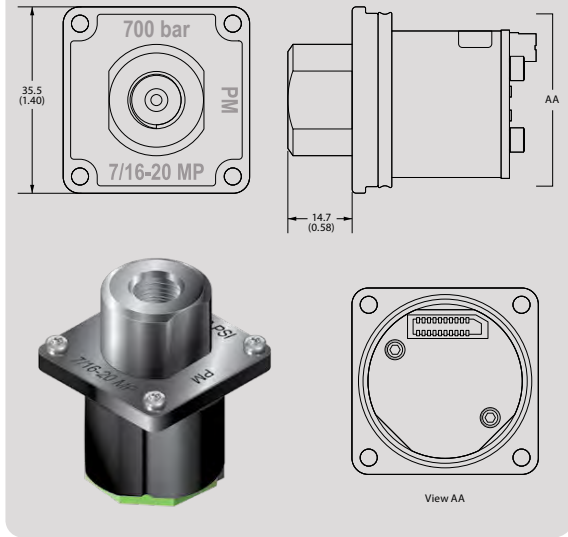

DIFFERENTIAL PRESSURE MEASUREMENT UNCERTAINTIES WITH TARE

The Tare function can improve measurement uncertainties on two modules with the same full scale pressure range installed into one nVision Reference Recorder. Requires the use of an equalizing valve.

The following specifications apply to the measurement system with a logging interval of 1 second/reading:

Full Scale Range of Both Sensors	The Greater of (+/-)				or	% of DP Reading
	bar	mbar	psi	inH ₂ O		
3	0.04	0.0005	0.014	0.4	or	0.025%
10	0.10	0.0015	0.04	1.0	or	0.025%
30	0.4	0.005	0.14	4.0	or	0.025%
100	1.0	0.02	0.4	10.0	or	0.05%
300	4.0	0.05	1.4	n/a	or	0.05%
700	10.0	0.2	4.0	n/a	or	0.05%
1000	15.0	0.3	6.0	n/a	or	0.05%

Unit must be enabled in CrystalControl

DIFFERENTIAL PRESSURE MEASUREMENT UNCERTAINTIES WITHOUT TARE

The total nVision Reference Calibrator measurement uncertainty in the ΔP mode configuration will need to consider the uncertainties of both pressure modules. We recommend the module uncertainties to be combined with the preferred square root of the sum of the squares (or “root sum squares”) method.

The following table lists the possible combinations of using Pressure Modules (PM) with different accuracy statements. The uncertainties reported below are without the use of the Tare feature, which will greatly improve your measurement uncertainty.

Lower Pressure Module Uncertainties (of Static Line Pressure) (of Reading)		Upper Pressure Module Uncertainties (of Static Line Pressure) (of Reading)	
		0.025%	0.05%
	0.025%	0.035%	0.056%
	0.05%	0.056%	0.071%

SENSOR

Wetted Materials: (WRENCH TIGHT) **316 stainless steel**
 (FINGER TIGHT) **316 stainless steel**
and Viton® (internal o-ring)

Diaphragm Seal Fluid: **Silicone Oil**

Connection: **Crystal CPF* Female**

All welded, with a permanently filled diaphragm seal.
Metal to metal cone seal; O-ring can be removed if necessary.
1/4" medium pressure tube system compatible with HIP LMA and LF4 Series, Autoclave Engr SF250CX Male and Female Series.
CPF Adapters to NPT, BSP, and M20 available.
 *U.S. Patent No. 8,794,677

BAROMETRIC REFERENCE (BARO)

Accuracy: **± 0.5 mbar, ± 0.00725 psi**

Range: **700.0 to 1100.0 mbarA,**
10.153 to 15.954 psiA

Units and Resolution: **psi** **0.001**
inHg **0.001**
mmHg **0.01**
mbar **0.1**

Pressure Connection: **Cylindrical sensor fitting of 5.8mm OD. A flexible 4.8 mm [3/16"] ID tube is recommended to connect for calibration.**

Mounting: **Secured using a 3/8" 4-40 plastic screw.**

Includes all effects of linearity, hysteresis, repeatability, temperature, and stability for one year.
Exposure to environmental extremes of temperature, shock, and/or vibration may warrant a more frequent recertification period.
Other units available depending on the installed modules.
Plastic non-conductive screw must be used to comply with hazardous location requirements.



Current, Voltage, & Switch Test Module (MA20)

Intended for use with a 4-20mA loop measurement. This module is also capable of measuring supply voltages and has an auxiliary fixed output for use in switch open/closure testing. Each MA20 module includes a super flexible silicone test lead kit (P/N 3952).

CURRENT & VOLTAGE MEASUREMENT

Current (mA) Input

- Accuracy: $\pm (0.015\% \text{ of rdg} + 0.002 \text{ mA})$
- Range: **0 to 55 mA (MA20)**
- Max Allowable Current: **93.3 mA**
- Resolution: **0.001 mA or 0.01%**
- Units: **mA, % 4-20, % 10-50**
- Input Resistance: **< 17.2 Ω**
- Voltage Burden @ 20mA: **< 0.35 V**
- Voltage Burden @ 50mA: **< 0.86 V**
- HART Resistance: **250 Ω**
- Connection: **2mm jacks**

Includes all effects of linearity, hysteresis, repeatability, temperature, and stability for one year.

For hazardous location product warnings, refer to the operation manual.

Inputs protected by a resettable fuse.

mA can be displayed as a percentage, where 0 to 100% corresponds to either 4 to 20 mA or 10 to 50 mA.

Jacks are compatible with safety sheathed banana plugs.

Voltage (VDC) Input

- Accuracy: $\pm (0.015\% \text{ of rdg} + 0.002 \text{ VDC})$
- Range: **0 to 28 VDC**
- Max Allowable Voltage: **30 VDC**
- Resolution: **0.001 VDC**
- Units: **VDC**

Includes all effects of linearity, hysteresis, repeatability, temperature, and stability for one year.

Switch Test

- Switch Type: **Dry Contact**
- Closed State Resistance: **< 10 Ω**
- Open State Resistance: **> 10 M Ω**

Switch state change indicated by bright green LED flash.

Switch test screen reports switch open, close, and deadband values.

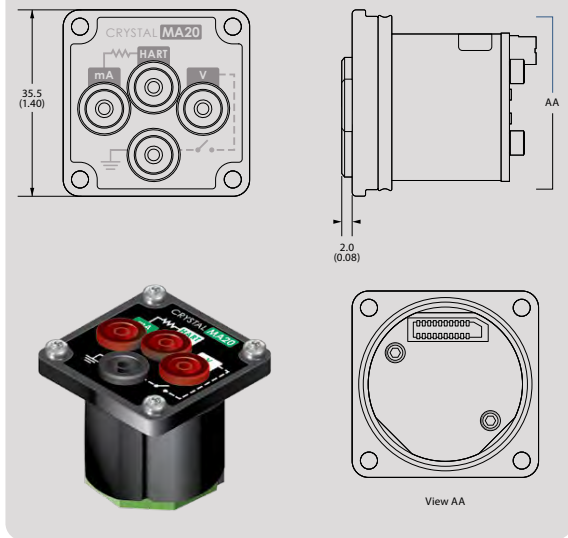

ATEX IEC IECEx ATEX and IECEx Scheme Entity Parameters

The MA20 Module has these specific input entity parameters:

- Ui = 28 V**
- li = 93.3 mA**
- Pi = 653.3 mW**
- Ci = 0.36 uF**
- Li = 39.1 uH**
- Uo = 6.6 V**
- Io = 4.45 mA**
- Po = 7.34 mW**
- Co = 0.5 uF***
- Lo = 12 uH****

* Dependent on the supply to the terminals but shall not be greater than 0.5 uF
 ** Total cable inductance between all modules

Temperature Module (RTD100)

Calibrated for Pt100 RTD/PRT (100 Ohms at 0°C Platinum Resistance Temperature Detector) sensors conforming to DIN/IEC 60751 (or IEC751) with US, Euro, or Lab calibration curves. An RTD is not included, but each RTD100 includes P/N 3953 RTD Connection Kit.

TEMPERATURE MEASUREMENT

Resistance Input

Accuracy: $\pm (0.015\% \text{ of rdg} + 0.02 \Omega)$

Range: **0 – 400 Ohms range for use with 100 Ohm PRTs**

Resolution: **0.01 on all scales**

Units: **°C, K, °F, R, Ω**

TCRs: **0.003850 $\Omega/\Omega/^\circ\text{C}$ (IEC 60751), 0.003911 $\Omega/\Omega/^\circ\text{C}$ (US Industrial Std), 0.003926 $\Omega/\Omega/^\circ\text{C}$**

Wiring: **2-, 3-, 4-wire support**

Connection: **M8 connector cable or terminal block**

Includes all effects of linearity, hysteresis, repeatability, temperature, and stability for one year.

The proper selection of the RTD sensing element is very important as the error associated with this device is the majority of the overall system measurement uncertainty. IEC 751 is the standard that defines the temperature versus resistance for 100 Ω , 0.00385 $\Omega/\Omega/^\circ\text{C}$ platinum RTDs. IEC 751 defines two classes of RTDs: Class A and B. Class A RTDs operate over the -200 to 630°C range versus -200 to 800°C for the Class B elements. For example, the Class A uncertainty is about half that of the Class B elements as illustrated in the following table.

Temperature °C	nVision Uncertainty		Class A				Class B			
			Class A Uncertainty		nVision + Class A Uncertainty		Class B Uncertainty		nVision + Class B Uncertainty	
	$\pm\Omega$	$\pm^\circ\text{C}$	$\pm\Omega$	$\pm^\circ\text{C}$	$\pm\Omega$	$\pm^\circ\text{C}$	$\pm\Omega$	$\pm^\circ\text{C}$	$\pm\Omega$	$\pm^\circ\text{C}$
-200	0.02	0.05	0.24	0.55	0.24	0.55	0.56	1.30	0.56	1.30
0	0.04	0.09	0.06	0.15	0.07	0.17	0.12	0.30	0.12	0.31
200	0.05	0.13	0.2	0.55	0.21	0.56	0.48	1.30	0.48	1.31
400	0.06	0.17	0.33	0.95	0.33	0.96	0.79	2.30	0.79	2.31
600	0.07	0.21	0.43	1.35	0.44	1.37	1.06	3.30	1.06	3.31
800	0.08	0.25	0.52	1.75	0.53	1.77	1.28	4.30	1.28	4.31

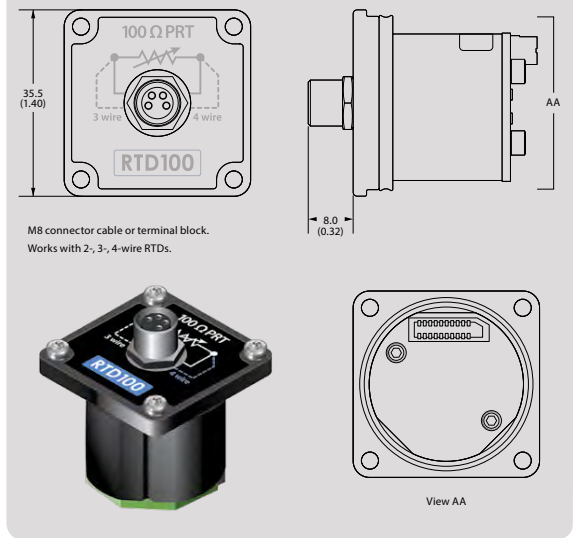

M8 connector cable or terminal block. Works with 2-, 3-, 4-wire RTDs.

View AA

ATEX IEC IECEx ATEX and IECEx Scheme Entity Parameters

The RTD100 Module has these specific input entity parameters:

- Ui = 0 V**
- li = 0 A**
- Pi = 0 W**
- Uo = 9.73 V**
- Io = 1.6642 A**
- Po = 1.1 W**
- Co = 0.5 uF**
- Lo = 12 uH***

* Total cable inductance between all modules

nVision Chassis (NV)

OPERATING TEMPERATURE

Temperature Range: **-20 to 50° C (-4 to 122° F)**

< 95% RH, non-condensing. No change in accuracy over operating temperature range. Gauge must be zeroed to achieve rated specification.

Applies to all modules.

DISPLAY

Screen: **255 x 160 pixel graphical display**

LCD readable in sunlight with bright backlight.

Display Rate: **4 readings/second (standard)**

up to 10 readings/second (recording)

POWER

The nVision is Intrinsically Safe only if powered by one of the following battery types.

ATEX/IECEx:	Approved Battery Type	Ta=	Marking
	Rayovac Max Plus 815	-20 to 50° C	Ex ia IIB T4 Ga
	Duracell MN1500	-20 to 45° C	
	Energizer E91, EN91	-20 to 50° C	Ex ia IIB T3 Ga
	Duracell MN1500		

CSA:	Approved Battery Type	Ta=	Marking
	Rayovac Max Plus 815	-20 to 50° C	Class I, Division 1, Grp C, D T4
	Duracell MN1500	-20 to 45° C	
	Energizer E91	-20 to 50° C	Class I, Division 1, Grp C, D T3B
	Energizer EN91		Class I, Division 1, Grp C, D T3A
	Duracell MN1500		Class I, Division 1, Grp C, D T3C

4 x AA: **200 hours, typical**

Ultra Low Power: **Up to 60 days, typical***

*2 installed modules, 1 reading per 5 minute recording interval, and 23° C ambient temperature.

Uses 4 alkaline AA (LR6) batteries. Use of backlight reduces operating time.

For hazardous location product warnings, refer to the operation manual.

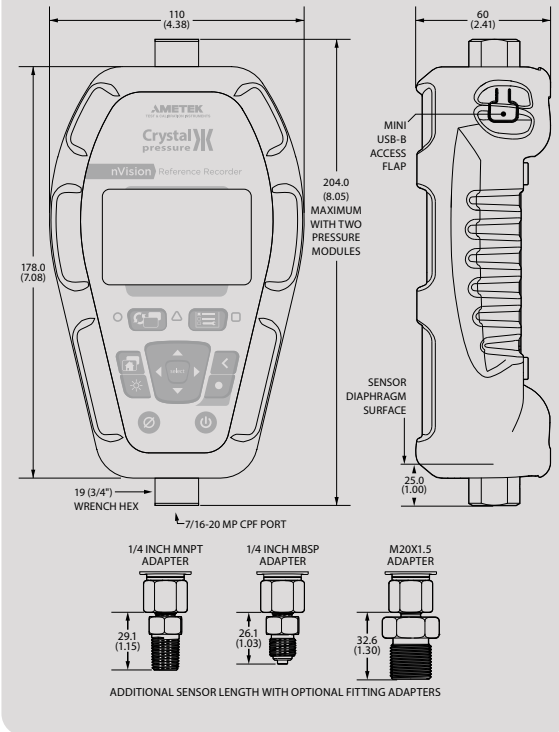

DATA/COMMUNICATION

Digital Interface: **mini-USB**

The mini USB will power the nVision with or without the battery pack installed.

For hazardous location product warnings, refer to the operation manual.

DATALOGGING

Capacity: **Approx. 1,000,000 data points***

**Single Module Recording*

Storage Type: **Non-volatile flash memory**

Limit of 64 individual recordings.

Fastest Interval: **10 per second**

The included CrystalControl software is compatible with Vista (SP 2), Windows 7 (SP 1), Windows 8.1 and Windows 10.

Slowest Interval: **1 per hour**

Produces csv, xls, pdf, or signed pdf files, and uses Excel template files (samples included) to automatically format and graph data.

ENCLOSURE

Weight: **680 g (24.0 oz)**

Weight includes one pressure module, one RTD module, 4AA battery module, and protective boot.

Rating: **IP66 and IP67**

Submersible to 1 m for 30 minutes [IEC 60529].

Housing: **Impact resistant injection molded**

LCD protected from impact damage by 1.5 mm (0.06") thick polycarbonate lens.

Keypad and Labels: **UV Resistant Polyester**

Mounting: **M4 x 0.7 [8 mm (0.31")]** deep threaded insert mounting locations

Skydrol® compatible.

For hazardous location product warnings, refer to the operation manual.

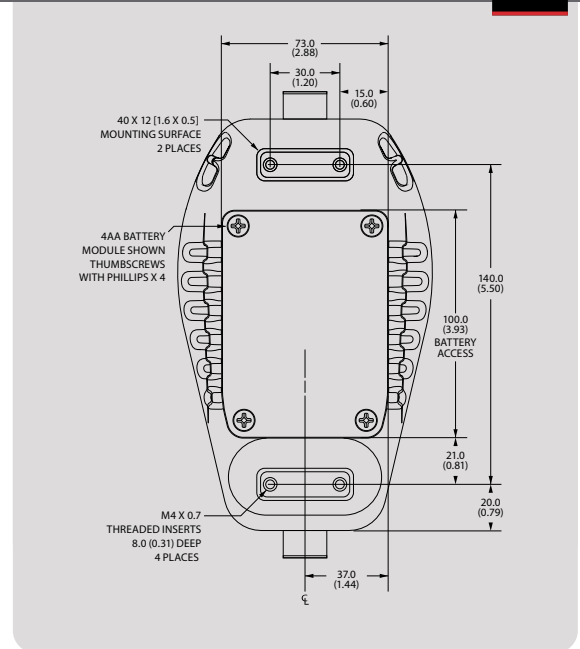

STORAGE TEMPERATURE

Temperature Range: **-40 to 75° C (-40 to 167° F)**

Batteries should be removed if stored for more than one month.

SPECIAL FEATURES

The following requires the use of our free [CrystalControl](#) software

Averaging Screen: **Averages all points in a recording run.**

Data Point Counter: **Screen for counting the data points logged.**

Display Screens: **Turn on and rearrange display screens.**

Estimated Recording Time: **A CrystalControl calculation based on active screens and logging interval.**

Live PC Graph: **During a recording, graph directly to your PC.**

Password Protect: **Changes to configuration or userspan calibration factor(s).**

Pressure Switch Test: **Using a PM and MA20, get deadband and state-change pressure.**

Remove: **Unwanted pressure units.**

Run Tags: **Create and enable run tags that will identify logging runs.**

Screen Numbers: **Number each display screen to make writing procedures around the nVision easier.**

Secure Documents: **Download into secure pdf documents for tamper proof records.**

Start-up Screen: **Define a 32-character prompt which requires user acknowledgement at startup.**

User Defined Unit: **Define and display any pressure units not included, or to use the gauge to display force, level or other pressure related parameters.**

STANDARD DELIVERY

- nVision Recorder
- CD Manual
- ISO 17025 Accredited Calibration Certificate, NIST Traceable
- Soft Carrying Case **P/N 5535**
- Protective Boot **P/N 3985**
- Mini-USB Cable **P/N 3951**

COMPLEMENTARY PRODUCTS

Crystal Engineering offers a wide range of products that work with the nVision:

- [Fittings that connect without tools, safely and without leaks](#)
- [Lightweight, super flexible high pressure hoses](#)
- [Fitting kits and adapters](#)
- [Pneumatic hand pumps](#)
- [Hydraulic hand pumps](#)
- [Portable pressure comparators](#)
- [Software, for the quickest way to calibrate pressure transmitters and gauges](#)

CERTIFICATIONS



**II 1G Ex ia IIB T4 Ga or T3
SIRA 09 ATEX 2008X**



**Ex ia IIB T4 Ga or T3
IECEX SIR 09.0053X**



Exia Intrinsically Safe and Non-incendive for Hazardous Locations: Class I, Division 1, Groups C and D, Temperature Code T4/T3A/TCB/T3C. For hazardous location product warnings, refer to the operation manual.



nVision complies with the Electromagnetic Compatibility and the Pressure Equipment Directives.



nVision complies with the Australian Radiocommunications (Electromagnetic Compatibility) Standard 2008.



nVision is approved for use as a portable test instrument for Marine use and complies with Det Norske Veritas' Rules for Classification of Ships, High Speed & Light Craft and Offshore Standards.

ACCESSORIES

BARO Calibration Kit P/N 4547

Magnetic Hanging Strap P/N 5177

Waterproof Carrying Case P/N 2888

RTD Terminal Block P/N 3953 (included with RTD100 module)

Test Lead Kit P/N 3952 (included with MA20 Module)

RANGE & RESOLUTION TABLE

PM	Range (bar)	Over-pressure	Display Resolution									
			bar	mbar	kPa	MPa	psi	in H ₂ O	in Hg	mm Hg	mm H ₂ O	kg/cm ²
3BAR	3	3.0 x	0.0001	0.1	0.01		0.001	0.01	0.001	0.01	1	0.0001
10BAR	10	2.0 x	0.0001	0.1	0.01	0.00001	0.001	0.1	0.01	0.1	1	0.0001
30BAR	30	2.0 x	0.001	1	0.1	0.0001	0.01	0.1	0.01	0.1		0.001
100BAR	100	2.0 x	0.001		0.1	0.0001	0.1		0.1			0.001
300BAR	300	1.5 x	0.01		1	0.001	0.1		0.1			0.01
700BAR	700	1.5 x	0.01		1	0.001	1					0.01
1KBAR	1000	1.3 x	0.01		1	0.001	1					0.01

(Add one digit of resolution for differential mode.)

ORDERING INFORMATION*

Model	Power	Upper Module	Lower Module	BARO Module	Pump System*	Carrying Case~
NV	4AA					
Pressure:		PM	PM	No ... (omit)	No Pump... (omit)	
Current, Voltage, and Switch:		MA20	MA20	Yes... BARO	System A... -AXX	Aluminum ... (omit)
Temperature:		RTD100	RTD100		System A... -AHX	Waterproof... -W
Blank Plate:		BNKPLT	BNKPLT		System B... -BXX	
					System B... -BHX	
					System C... -CXX	
					System C... -CHX	
					System D... -DOX	
					System D... -DWX	
					System E... -EOX	
					System F... -FOV	
					System F... -FVW	
					System G... -GOX	
					System G... -GWX	
					System H... -HOX	

If ordering an nVision with only one module installed, enter **BNKPLT** in the empty module slot.

SAMPLE PART NUMBERS

NV-4AA-**3BAR**-**300BAR**-**BARO**... nVision with 3 bar pressure module (upper) and 300 bar pressure module (lower); and a BARO module option.

NV-4AA-**RTD100**-**700BAR**-**GWX**-W... nVision with RTD100 temperature module (upper) and 700 bar pressure module (lower); a System G pump system; and a waterproof carrying case.

AMETEK offers a variety of solutions for pressure generation and measurement. Our line of products for pressure generation includes everything from small pneumatic hand pumps to a precision, hydraulic pressure comparator capable of generating up to 15 000 psi / 1000 bar / 100 MPa.

All of our pumps may be ordered as part of a Pump System, complete with an nVision and delivered in a sturdy carrying case with custom insert.

* Refer to the following page for a more detailed description of each pump system.

~ The Waterproof Case is an option for Systems A, B, and C only.
The Waterproof Case is the only option for Systems G and H.

► Ordering a Pump System Only















Any pump system, carrying case, and connection fittings for an nVision reference recorder may be ordered separately from the gauge. Enter NV-NONE followed by the Pump System part number and the Carrying Case option code.

SAMPLE PART NUMBERS

NV-NONE-GWX-W... System G pump system with a waterproof carrying case.

* BAR versions available in USA direct from factory only.

PUMP SYSTEMS OVERVIEW

Pump System	Part Number	Pressure Range	Pneumatic	Hydraulic	Hand Pump	Bench Top	Included Pump	Case Options	
								Aluminum	Waterproof (Pelican Case)
System A	AXX	0 to 30psi /2 bar	■		■		 T-960-CPF	■	■
	AHX	0 to 580 psi /40 bar	■		■		 T-970-CPF	■	■
System B	BXX	-25 inHg to 30 psi /-0.85 to 2 bar	■		■		 T-965-CPF	■	■
	BHX	-27 inHg to 580 psi /-0.91 to 40 bar	■		■		 T-975-CPF	■	■
System C	CXX	0 to 3000 psi /200 bar		■ (Oil)	■		 T-620-CPF	■	■
	CHX	0 to 5000 psi /350 bar		■ (Oil)	■		 T-620H-CPF	■	■
System D	DOX	0 to 5000 psi /350 bar		■ (Oil)		■	 P-018-CPF	■	
	DWX	0 to 5000 psi /350 bar		■ (Water)		■	 P-014-CPF	■	
System E	EOX	0 to 10 000 psi /700 bar		■ (Oil)		■	 T-1-CPF	■	
System F	FOV	0 to 15 000 psi /1000 bar		■ (Oil)		■	 GaugeCalHP		■
	FWV	0 to 15 000 psi /1000 bar		■ (Water)		■	 T-975-CPF	■	■
System G	GOX	0 to 15 000 psi /1000 bar		■ (Oil)		■	 T-620H-CPF		■
	GWX	0 to 15 000 psi /1000 bar		■ (Water)		■	 T-975-CPF		■
System H	HOX	-27 inHg to 580 psi /-0.91 to 40 bar	■		■		 T-975-CPF		■
		0 to 5000 psi /350 bar		■ (Oil)	■		 T-620H-CPF		■