

**Operation Manual**



Warning

Laser radiation may be harmful to the human eye. Avoid direct exposure of human eyes to laser light. Eye damage can result.

Never point the unit at another person.

Keep out of the reach of children.

Avoid indirect exposure via reflective materials such as glass and mirrors.

When power button is depressed, laser is active.

When using the master wheel, do not use an extension shaft as the wheel may come off of the shaft and cause damage or injury.

Although the tachometer is able to achieve higher measurements than what is listed, the master wheel has a maximum speed limitation of 5000 ft/min (for safety reasons).

CAUTION



LASER RADIATION  
DO NOT STARE INTO BEAM  
OUTPUT < 1mW  
WAVELENGTH 670nm  
CLASS II LASER PRODUCT



The MT-200 Combination Contact/Non-Contact Pocket Tachometer with microprocessor technology possesses the precision of the standard Shimpo Tachometer line, yet within a compact, pocket-style enclosure. These battery-operated tachometers feature the same rugged, high quality components that have made Shimpo tachometers the benchmark in the industry. The MT-200 provides users with the capabilities of measuring and recording speeds of rotational, linear and surface plus total length in both contact or non-contact modes. The user-friendly, value-packed units feature memory storage; quick selection unit's button; length functions; retrieval of last, maximum and minimum values; plus each unit comes standard with a free N.I.S.T. calibration certificate. Each unit ships in a protective carrying case which includes a cone adapter, funnel adapter and 6" circumference wheel.

**SPECIFICATIONS**

- Display Range:** RPM Non-Contact: 6.0 - 99,999 RPM Contact: 6.0 - 25,000 RPM; Revolutions (total) Non-Contact & Contact: 1 - 99,999; Speed Using 6" Cir. Wheel: meters/min: 0.1 - 3,809.8; yards/min: 1.0 - 4,166.4; inch/min: 36 - 99,999; feet/min: 3.0 - 12,499; Length Using 6" Cir. Wheel: meters: 0.2 - 99,999; yards: 0.2 - 99,999; feet: 0.5 - 99,999
- Accuracy:** Revolution: 6.0 - 599.9 rpm:  $\pm 1$  rpm ; 600 - 99,999 rpm:  $\pm 0.006\%$  of reading  $\pm 0.5$  digit; Surface Speed, Length:  $\pm 0.4\%$  of reading  $\pm 1$  digit
- Display:** 5 digit 0.47" (12 mm) high LCD
- Memory System:** Readings are stored in memory and retained for 5 minutes (last, max., min., and 10 user logged measurements)
- Detection:** Laser diode
- Update Time:** 1 second (typical)
- Over Range Indicator:** Flashing numerals
- Power Requirement:** 3 AA 1.5V batteries
- Operating Temperature:** 32° - 113°F (0° - 45°C)
- Construction:** ABS Resin housing
- Product Weight:** 0.35 lb (160 g); 0.46 lb ( 210 g) With contact adapter installed
- Package Weight:** 0.85 lb (386 g)
- Dimensions:** Main unit: 4.55"L x 2.52"W x 1.24"H (115.5 mm x 64 mm x 31.5 mm) Overall Length with contact adapter: 5.9" (149 mm)
- Warranty:** 2-Year
- Included Accessories:** Three AA Batteries, cone adapter, funnel adapter, contact adapter, master wheel (6" cir.), reflective tape, carrying case, NIST certificate

**DISPLAY**

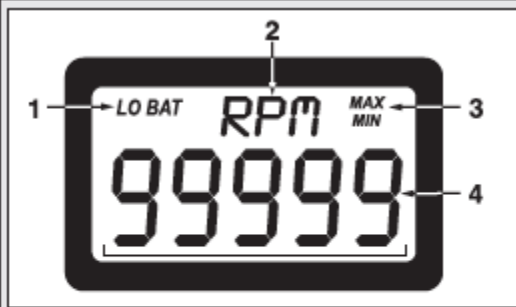

1. Low battery display  
2. Tachometer's display  
3. Max/Min display  
4. Main display

## OPERATION

### Non-Contact Measurements

Measuring revolutions per minute or total revolutions.

1. Attach a piece of reflective tape on the object to be measured.

**NOTE:** Accurate measurement may not be achieved if the rotating object to be measured is shiny. Cover with black tape or paint then attach the reflective tape.

2. Press the POWER button to turn the tachometer on.

3. Select RPM (revolutions per minute) or REV (total number of revolutions) by pressing the UNIT button.

4. Aim the laser beam at the reflective tape.

5. Press and hold down the POWER button to start measuring.

6. Press and hold the POWER button to take another measurement.



Warning

Laser - Do not look into the beam. Use protective eyeglasses that are rated for 670usec for adequate eye protection.

### Contact Measurements

Measuring rotation speed using the cone or funnel-shaped contact probe.

1. Attach the contact adapter to the tachometer. Do not over tighten.

2. Attach the cone or funnel adapter to the tachometer by placing on the adapter shaft. Align the shaft pin with the notch of the adapter stem.

3. Press the POWER button to turn the tachometer on.

4. Select RPM (revolutions per minute) or REV (total number of revolutions) by pressing the UNIT button.

5. Press and hold the POWER button to start measuring.

6. Bring the contact probe into contact with the object to be measured by touching the contact probe slowly to the center of the rotating object. If the measuring range of the tachometer is exceeded, "OVR" will appear on the tachometer's display.

7. Press and hold the POWER button to take another measurement.

8. Press the UNIT button to convert between ranges. When a high-speed rotating object is measured for hours using a cone or funnel adapter the surface of the adapter may become very hot.



Warning

When a high-speed rotating object is measured for hours using a cone or funnel adapter the surface of the adapter may become very hot.

Measuring surface speed and distance using the 6" circumference wheel.

1. Attach the contact adapter to the tachometer. Do not over tighten.

2. Attach the 6" circumference wheel to the tachometer by placing the wheel on the adapter shaft. Align the shaft pin with the notch of the wheel stem.

### 6" Circumference Wheel Dimensions

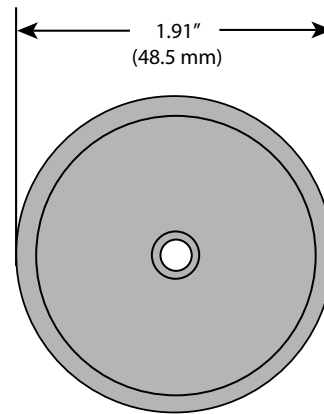

3. Press the POWER button to turn the tachometer on.

4. Select meters/minute (m/M), yards/minute (Y/M), inches/minute (I/M), feet/minute (F/M), meters (m), yards (YRd), feet (FT), or inch (IN) depending on which units you wish to measure.

5. Bring the 6" circumference wheel into contact with the object to be measured by slowly touching the wheel to the moving object.

6. Press and hold the POWER button to start measuring.

7. Press the UNIT button to convert between ranges. When making surface speed or distance measurements, ensure that the 6" circumference wheel's perimeter is parallel to the object to be measured.



Warning

When making surface speed or distance measurements, ensure that the 6" circumference wheel's perimeter is parallel to the object to be measured.

**NOTE:** When using the master wheel, accuracy can be affected as much as 0.3% of reading.

## Memory Function

The tachometer's memory capabilities are as follows:

1. Minimum, maximum and last measurements are recorded automatically by the tachometer.
2. Ten selectable measurements can be programmed into memory by pressing the MEM button while the POWER button is fully depressed (M1, M2, M3, ... M10).
3. The average value of sequentially stored memory, up to ten, can be viewed by pressing the MEM button.

**NOTE:** If the memory button (MEM) is not selected while the POWER button is pressed the measurement will not be recorded into its memory location, The memory will be recorded automatically into memory if the measurement made is the maximum, minimum or last measurement.

To delete stored memories do one of the following:

1. Press the MEM button for five seconds or more. All memory will be erased after [CCCCC] is displayed.
2. Changing the units of measurements and then making additional measurements.
3. Memory will be automatically erased if the tachometer turns off automatically after five minutes.

## Battery Replacement

When "LO BAT" flashes on the display, install new batteries. To replace the batteries:

1. Slide open the battery cover (located on the rear of the tachometer).
2. Remove old batteries and insert three fresh AA size batteries, observing proper polarity. Do not mix old and new batteries.
3. Slide the battery cover back into place.

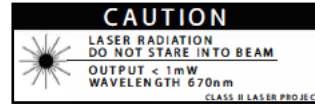

## TROUBLESHOOTING

No laser beam is evident:

- Confirm that the POWER button is operating properly.
- Confirm that the batteries are functioning properly and that they are inserted into the tachometer with correct polarity.

Inaccurate measurement results:

- If the surface being measured is highly reflective, it may need to be painted darker to ensure that the tachometer can distinguish between the reflective tape and the background.
- The laser beam may not be hitting the reflective tape, or the taped area may be too small.
- Measuring distance may be too short. The minimum distance for non-contact measurements is 12.7cm

**DIMENSIONS**

