



# Easidew Dew-Point Transmitter User Manual



97504 Issue 3.3  
March 2022

Please fill out the form(s) below for each instrument that has been purchased.

Use this information when contacting Michell Instruments for service purposes.

Product Name	
Order Code	
Serial Number	
Invoice Date	
Installation Location	
Tag Number	

Product Name	
Order Code	
Serial Number	
Invoice Date	
Installation Location	
Tag Number	

Product Name	
Order Code	
Serial Number	
Invoice Date	
Installation Location	
Tag Number	



## Easidew

© 2022 Michell Instruments

This document is the property of Michell Instruments Ltd and may not be copied or otherwise reproduced, communicated in any way to third parties, nor stored in any Data Processing System without the express written authorization of Michell Instruments Ltd.

## Contents

Safety .....	vi
Electrical Safety .....	vi
Pressure Safety .....	vi
Toxic Materials.....	vi
Repair and Maintenance.....	vi
Calibration.....	vi
Safety Conformity .....	vi
Abbreviations .....	vii
Warnings .....	viii
1 INTRODUCTION .....	1
2 INSTALLATION.....	2
2.1 Unpacking the Transmitter.....	2
2.2 Easidew Transmitter.....	3
2.2.1 Easidew DIN 43650 Connector Version .....	3
2.2.1.1 Electrical Connections .....	4
2.2.1.2 Cable Connection to Transmitter .....	4
2.2.1.3 Sensor Cable Self-Assembly .....	5
2.2.2 Easidew M12 Connector Version.....	6
2.2.2.1 Electrical Connections .....	6
2.2.2.2 Easidew M12 Cables .....	7
2.2.3 4...20 mA wiring schematics .....	7
2.2.4 RS485 / Modbus RTU communication & wiring schematics .....	8
2.2.5 Cable Selection for Self-Assembled Cables .....	9
2.2.6 Maximum Loop Resistance vs Supply Voltage .....	9
2.3 Transmitter Mounting .....	10
2.3.1 5/8" 18 UNF Version.....	10
2.3.2 3/4" - 16 UNF Version .....	10
2.3.3 G1/2" BSPP Version.....	10
2.3.4 Transmitter Mounting – Sample Block (Optional) .....	11
2.3.4.1 Sample Block Gas Connections .....	11
2.3.4.2 Sensor Installation .....	12
2.3.5 Transmitter Mounting – Direct Pipeline Connection .....	13
2.3.6 Transmitter Mounting – With Additional Process Connection Adapter .....	14
3 MAINTENANCE .....	15
3.1 Maintenance and Calibration .....	15
4 MEASUREMENT GUIDE.....	17
4.1 Sampling Considerations .....	17
4.2 Sampling Hints .....	20

## Figures

Figure 1	DIN43650 Transmitter Unpacking Method .....	2
Figure 2	Easidew Transmitter .....	3
Figure 3	Connector Installation.....	4
Figure 4	Connector Terminal Block Removal .....	5
Figure 5	Cable Assembly.....	5
Figure 6	Sensor Connector Installation.....	6
Figure 7	Maximum Load of Easidew – Including Cable Resistance.....	9
Figure 8	Sample Block Gas Connections.....	11
Figure 9	Transmitter Mounting – Sensor Block.....	12
Figure 10	Transmitter Mounting – Pipe or Duct.....	13
Figure 11	Transmitter Mounting with Adapter .....	14
Figure 12	Replacement of HMWPE Guard.....	15
Figure 13	Installation Location .....	18
Figure 14	Installation Location .....	18
Figure 15	Material Permeability Comparison.....	20
Figure 16	Dead volume .....	21
Figure 17	Dimensions - Easidew .....	25

## Appendices

Appendix A	Technical Specifications .....	24
Appendix B	Modbus Register Map .....	27
Appendix C	Quality, Recycling & Warranty Information .....	31
Appendix D	Return Document & Decontamination Declaration.....	33

## Safety

The manufacturer has designed this equipment to be safe when operated using the procedures detailed in this manual. The user must not use this equipment for any other purpose than that stated. Do not apply values greater than the maximum value stated.

This manual contains operating and safety instructions, which must be followed to ensure the safe operation and to maintain the equipment in a safe condition. The safety instructions are either warnings or cautions issued to protect the user and the equipment from injury or damage. Use competent personnel using good engineering practice for all procedures in this manual.

## Electrical Safety

The instrument is designed to be completely safe when used with options and accessories supplied by the manufacturer for use with the instrument.

## Pressure Safety

DO NOT permit pressures greater than the safe working pressure to be applied to the instrument. The specified safe working pressure is 45 MPa (450 barg / 6500 psig). Refer to the Technical Specifications in Appendix A.

## Toxic Materials

The use of hazardous materials in the construction of this instrument has been minimized. During normal operation it is not possible for the user to come into contact with any hazardous substance which might be employed in the construction of the instrument. Care should, however, be exercised during maintenance and the disposal of certain parts.

## Repair and Maintenance

The instrument must be maintained either by the manufacturer or an accredited service agent. For

## Calibration

The recommended calibration interval for this instrument is 12 months unless it is to be used in a mission-critical application or in a dirty or contaminated environment in which case the calibration interval should be reduced accordingly. The instrument should be returned to the manufacturer, Michell Instruments Ltd., or one of their accredited service agents for re-calibration.

## Safety Conformity

This product meets the essential protection requirements of the relevant EU, UK and US standards and directives. Further details of applied standards may be found in the Technical Specifications in Appendix A.

## Abbreviations

The following abbreviations are used in this manual:

barg	pressure unit (=100 kP or 0.987 atm) gauge
°C	degrees Celsius
°F	degrees Fahrenheit
DC	direct current
ft-lbs	foot-pound force
g	grams
in	inch(es)
µm	micrometer
m/sec	meters per second
mA	milliamperere
max	maximum
mm	millimetres
MPa	megapascal
NI/min	normal liters per minute
Nm	Newton meter
oz	ounces
ppm <sub>v</sub>	parts per million by volume
psig	pounds per square inch
RH	relative humidity
scfh	standard cubic feet per hour
scfs	standard cubic feet per second
T	temperature
V	Volts
Ω	Ohms
∅	diameter

## Warnings

The following general warning listed below is applicable to this instrument. It is repeated in the text in the appropriate locations.



**Where this hazard warning symbol appears in the following sections it is used to indicate areas where potentially hazardous operations need to be carried out.**



## **1 INTRODUCTION**

The Michell Instruments Easidew is a loop-powered dew-point transmitter, designed to make dew-point measurements in a flowing sample. The Easidew transmitter is available with 3 different process connections:

- 5/8" - 18 UNF: Easidew 2-wire, Easidew M12
- 3/4" - 16 UNF: Easidew 34, Easidew M12
- G1/2: Easidew M12

The Easidew 2-wire is available with a choice of electrical connections:

- DIN 43650 Form C
- M12 5-Pin

## 2 INSTALLATION

### 2.1 Unpacking the Transmitter

On removing the transmitter from the box, please check that all the following standard components are included:

- Easidew Transmitter
- Certificate of Calibration
- Electrical Connector (DIN 43650 models only)

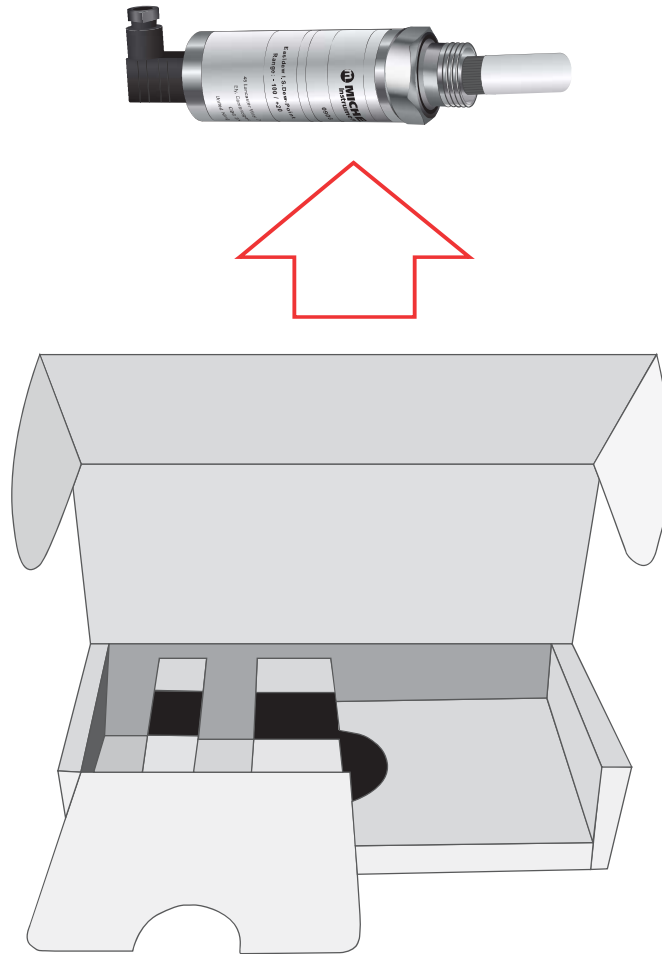

Figure 1 *DIN43650 Transmitter Unpacking Method*

The Transmitter will also be supplied with a process seal, which will be fitted to the unit. Depending on the version, this will either be a bonded seal (5/8" or G1/2" thread versions) or an o-ring seal (3/4" thread versions).

The transmitter sensing element is protected while in transit by a blue plastic cover containing a small desiccant capsule. The cover should be removed before operation but should be retained in case required for return shipping.

Depending on the model, the transmitter may come with the electrical connector fitted to protect the transmitter pins during transit. Keep the connector in a safe place until ready to wire up the sensor.

## 2.2 Easidew Transmitter

**NOTE:** The transmitter’s sensing element is shown for illustration purposes only. Please keep the guard fitted at all times, if possible.

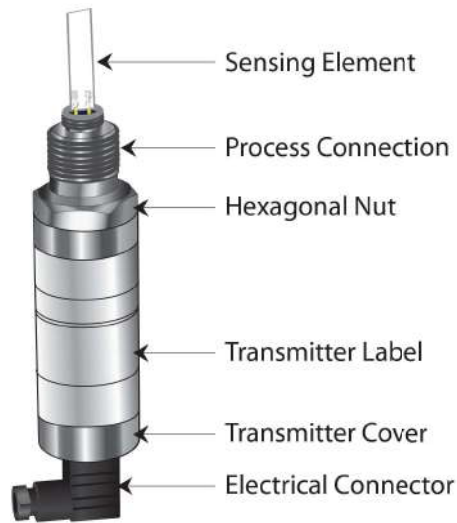

**Figure 2** *Easidew Transmitter*

### 2.2.1 Easidew DIN 43650 Connector Version

The following sections apply only to the DIN 43650 connector version of the transmitter.



## 2.2.1.1 Electrical Connections



Connector Pin	Michell Standard Conductor Colour	Function
1	Green	4...20 mA Signal Return (Power Supply -ve)
3	Red	Power Supply +ve
GND	Blue	Ground, Cable Screen Connection  This pin directly connects to the metal casing of the transmitter, but not to the transmitter electronics, and is intended for cable screening only.

**Warning:** The sensor must be operated with the 4...20 mA signal return connected to a suitable load, or negative power supply connection. Leaving this pin unconnected may result in damage to the transmitter. Refer to wiring schematics later on in this document for connection examples.

**NOTE:** The sensor cable is NOT supplied as standard. Replacement pre-wired cables can be obtained by contacting your local Michell Instruments representative or assembled by the user according to instructions in the following section.

## 2.2.1.2 Cable Connection to Transmitter

To ensure the specified ingress protection is achieved, when installing the connector, the securing screw (with the O-ring and washer) must be tightened to a minimum torque of 3.4 Nm (2.5 ft-lbs). The sensor cable used must be a minimum diameter of 4.6 mm (0.2").



Figure 3 *Connector Installation*

### 2.2.1.3 Sensor Cable Self-Assembly

For guidance on type of cable refer to Section 2.2.5, Cable Selection for Self-Assembled Cables.

#### Assembly Instructions

1. Remove the screw from the rear of the DIN connector housing.
2. Lever the terminal block from the connector housing by inserting a small screwdriver in the notch on the front face of the terminal block.
3. Ensure the small sealing O-ring and washer are retained with the screw.



Figure 4 Connector Terminal Block Removal

4. Cable should be assembled according to Figure 5.

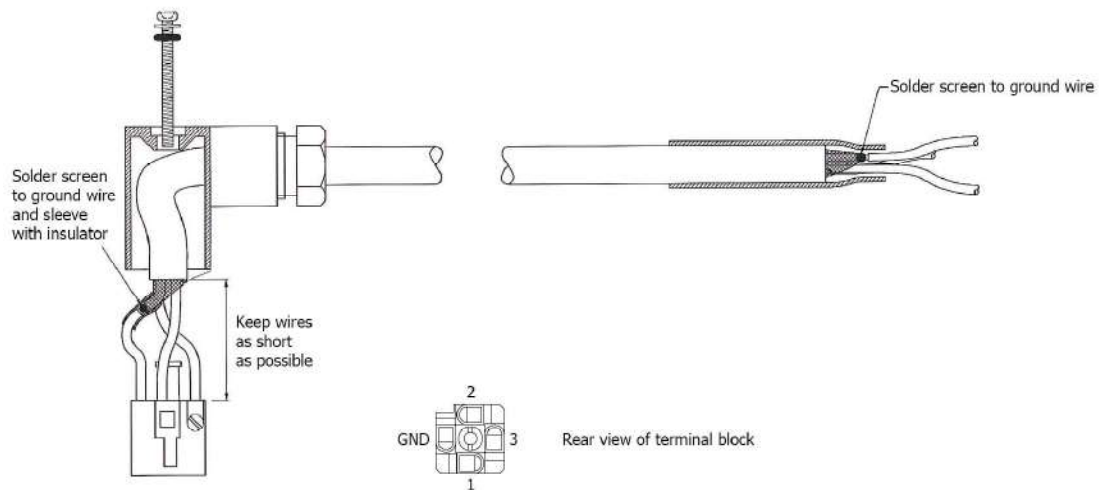

Figure 5 Cable Assembly

## 2.2.2 Easidew M12 Connector Version

The following sections apply only to the M12 connector version of the transmitter.



### 2.2.2.1 Electrical Connections

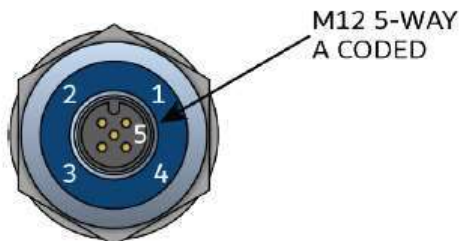

Connector Pin	Michell Standard Conductor Colour	Function
1	Brown	Modbus A
2	White	Modbus B
3	Blue	4...20 mA Signal Return (Power Supply -ve)
4	Black	Power Supply +ve
5	Grey	Ground, Cable Screen Connection  This pin directly connects to the metal casing of the transmitter, but not to the transmitter electronics, and is intended for cable screening only.

**Figure 6** *Sensor Connector Installation*

**Warning:** The sensor must be operated with the 4...20 mA signal return connected to a suitable load, or negative power supply connection. Leaving this pin unconnected may result in damage to the transmitter. Refer to wiring schematics later on in this document for connection examples.

**NOTE:** The sensor cable is NOT supplied as standard. Replacement pre-wired cables can be obtained by contacting your local Michell Instruments representative or assembled by the user according to instructions in the following section.

**2.2.2.2 Easidew M12 Cables**

The cable connector should be installed by aligning the locating pin on the transmitter with the slot on the cable. The connector can then be pushed into place and rotated until finger tight.

Cables with moulded M12 connectors are available from Michell Instruments in the following lengths:

- 0.8 m
- 2 m
- 5 m
- 10 m

The other end of the sensor cable is unterminated, for straightforward connection into the desired monitoring system.

If longer cable runs are required, off-the-shelf 5-pin M12 cables can be connected between the Easidew transmitter and the cable provided by Michell Instruments.

**2.2.3 4...20 mA wiring schematics**

**Example 1:** Connecting the transmitter using an external power supply to provide the excitation voltage

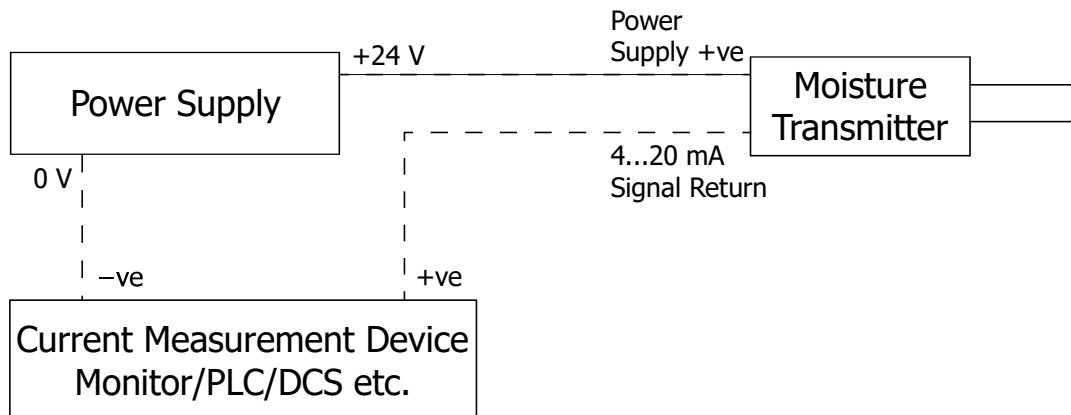

**Example 2:** Connecting the transmitter to a device that provides its own excitation voltage

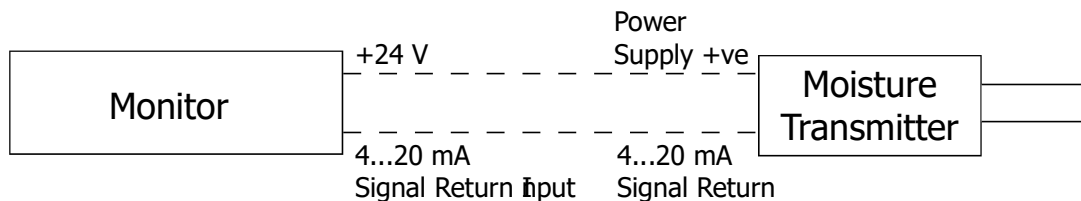

## 2.2.4 RS485 / Modbus RTU communication & wiring schematics



The M12 version of the transmitter should be used if continuous monitoring or measurement via the RS485 / Modbus interface is required. The RS485 interface on the DIN version is intended for configuration and diagnostics and should only be used with a Michell Instruments communications kit. Incorrect wiring of the transmitter may result in permanent damage.

Modbus RTU over RS485 communication is available on the Easidew M12 and can be used simultaneously with the 2-wire current output.

Full details of the Modbus communications is contained within Appendix B.

**Example 1:** Using only the RS485 / Modbus communications interface

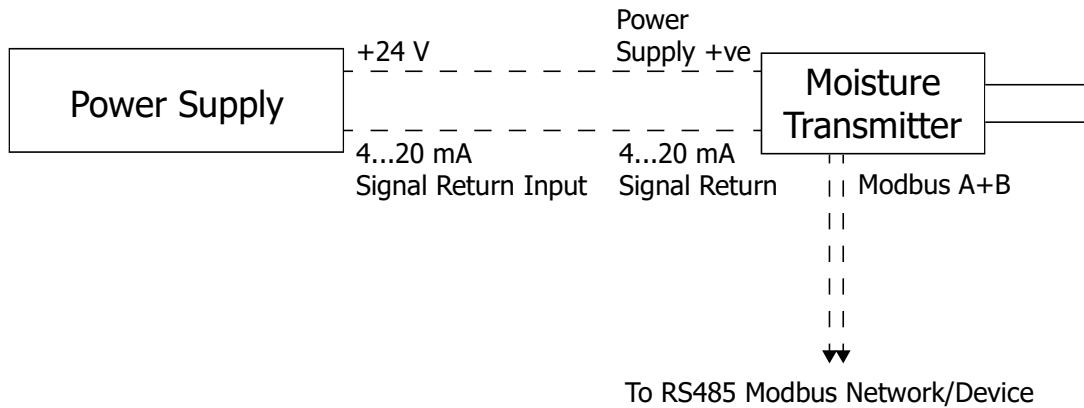

**Example 2:** Using both the 4...20 mA & RS485 / Modbus communication interfaces simultaneously

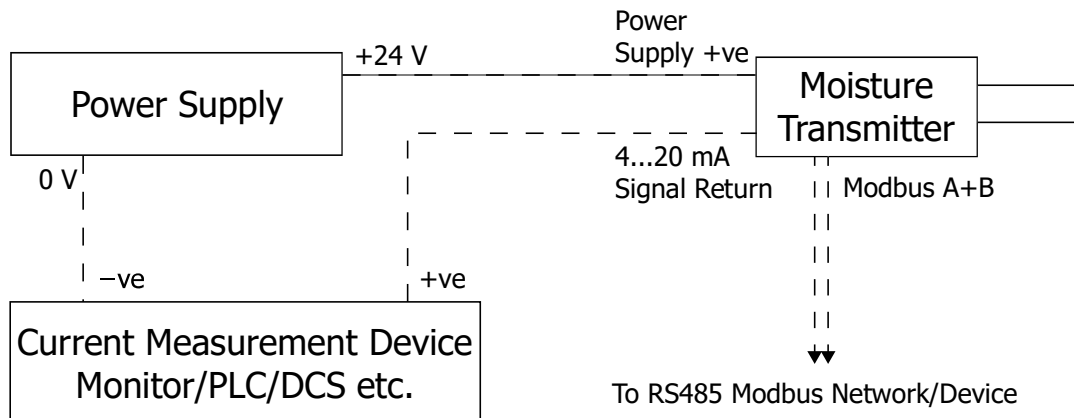



**2.2.5 Cable Selection for Self-Assembled Cables**

It is recommended to use 3-core screened cable. For short runs, a cable with individual conductor sizes of 24 AWG / 0.21mm<sup>2</sup> would be a typical choice. For longer runs, a cable with larger conductors may be required to keep loop resistance within allowable limits. A chart of maximum loop resistance vs supply voltage is provided in the following section to aid in cable selection.

**2.2.6 Maximum Loop Resistance vs Supply Voltage**

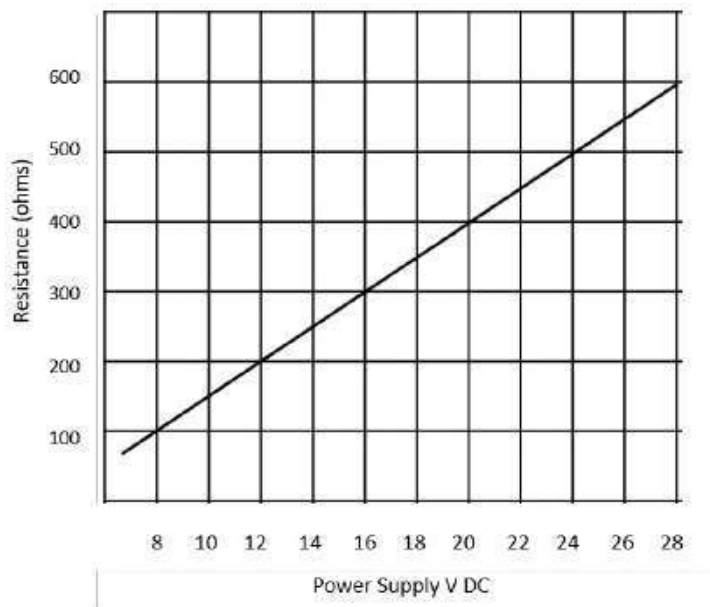

Figure 7 *Maximum Load of Easidew – Including Cable Resistance*

**NOTE:** Cable resistance of the entire loop must be considered when calculating loop resistance.

## 2.3 Transmitter Mounting

### 2.3.1 5/8" 18 UNF Version

1. Remove the protective cover and desiccant capsule from the transmitter and retain for future use
2. Prevent any contamination of the sensor before installation by handling the transmitter by the main body only, avoiding contact with the sensor guard.
3. Pass the bonded seal over the 5/8"- 18 UNF mounting thread.
4. Screw the transmitter into the sampling location or sample block by hand using the wrench flats only. **DO NOT grip and twist the sensor cover when installing the sensor.**
5. When installed, fully tighten using a wrench to a torque setting of 30.5 Nm (22.5 ft-lbs)

### 2.3.2 3/4" - 16 UNF Version

1. Remove the protective cover and desiccant capsule from the transmitter and retain for future use.
2. Prevent any contamination of the sensor before installation by handling the transmitter by the main body only, avoiding contact with the sensor guard.
3. Ensure that the O-ring is seated in the recess at the top of the transmitter body.
4. Screw the transmitter into the sampling location or sample block by hand using the wrench flats only. **DO NOT grip and twist the sensor cover when installing the sensor.**
5. When installed, fully tighten using a wrench to a torque setting of 40 Nm (29.5 ft-lbs).

### 2.3.3 G1/2" BSPP Version

1. Remove the protective cover and desiccant capsule from the transmitter and retain for future use
2. Prevent any contamination of the sensor before installation by handling the transmitter by the main body only, avoiding contact with the sensor guard.
3. Pass the bonded seal over the G1/2" mounting thread.
4. Screw the transmitter into the sampling location or sample block by hand using the wrench flats only. **DO NOT grip and twist the sensor cover when installing the sensor.**
5. When installed, fully tighten using a wrench to a torque setting of 30.5 Nm (22.5 ft-lbs)

### 2.3.4 Transmitter Mounting – Sample Block (Optional)



These procedures must be carried out by a qualified installation engineer.

#### 2.3.4.1 Sample Block Gas Connections

Sample gas connections are made to the Gas In and Gas Out ports on the sample block see *Figure 8*. Either port on the sample block may be used as the Gas Input port (i.e. for connection purposes the ports are interchangeable).

Normally, connections are made via stainless steel pipework, in which case the sensor block/transmitter assembly will be self supporting. If PTFE tubing is used it may be necessary to support the assembly with a body clip.

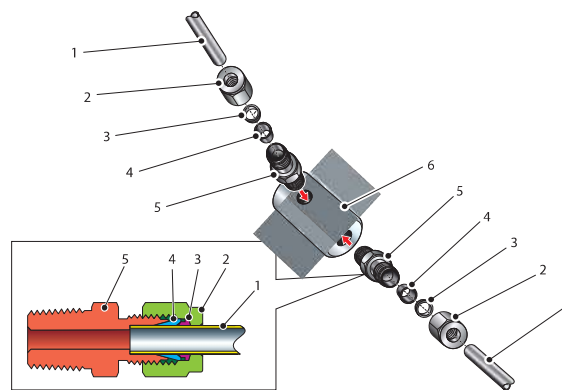

Figure 8 *Sample Block Gas Connections*

Both the Input and Output gas connections are  $\frac{1}{8}$ " NPT. It is recommended that both the Gas Input and Output connections are made via  $\frac{1}{8}$ " NPT to 6mm or  $\frac{1}{8}$ " NPT to  $\frac{1}{4}$ " stainless steel tube adaptors (2 to 5 – *Figure 8*). The method of connection to the sensor block (6) is as follows:

**NOTE: The following description relates to 6mm tube fixings. The sample block ports are both  $\frac{1}{8}$ " NPT female process connections. Tube adaptors are not supplied with the equipment but can be obtained by contacting your local**

1. Cut a suitable length of 6mm ( $\frac{1}{4}$ " U.S.) stainless steel tubing (1) and, if necessary, bend to shape to suit the location of the sensor block assembly. **NOTE: To facilitate ease of connection to the port, at least 75mm (3") of the tubing coming out of the Gas In port should be straight.**
2. Clean and deburr the inside and outside rim of the tubing at the connection point.
3. Using gas-fitters PTFE tape, wrap the NPT thread 2–3 times. The wrapping should leave the first thread clear and follow the direction of the thread.
4. Screw the  $\frac{1}{8}$ " NPT Swagelok adaptor (5) into the  $\frac{1}{8}$ " NPT inlet port in the sensor block (6) and tighten to a torque setting of 35 Nm (25 lbf-ft).

5. Pass the stainless steel tubing (1) through the locking nut (2). NOTE: Threads towards the gas port.
6. Fit the back ferrule (3) over the stainless steel tubing (1) with the bevelled end facing the back of the front ferrule (4).
7. Place the front ferrule (4) over the stainless steel tubing (1), bevelled end towards the adaptor (5).
8. Push the stainless steel tubing (1) as far as it will go into the adaptor (5) and tighten up the locking nut (2) finger tight.
9. Hold the adaptor (5) flats with a spanner and tighten up the locking nut (2) to a torque setting of 35 Nm (25 lbf-ft) (1¼ turns). This action compresses the front ferrule (4) and back ferrule (3) onto the tubing to form a gas tight seal.
10. Connect up the other gas port as described in steps 1 to 9 above.

### 2.3.4.2 Sensor Installation

To mount the transmitter into the sensor block (preferred method), proceed as follows, refer to *Figure 9*.

1. Ensure that the protective cover (2), and its desiccant capsule (2a), have been removed from the tip of the transmitter.
2. Fit the bonded seal (4) over the threaded part of the transmitter body.



**WARNING: Under no circumstances should the sensor guard be handled with the fingers.**

3. Screw the transmitter (1) into the sample block (3) and tighten to the recommended torque setting. **NOTE: Use the flats of the hexagonal nut and not the sensor body.**
4. Fit the transmitter cable/connector assembly to the plug located on the base of the transmitter and tighten the fixing screw (see Section 2.3.4.1).

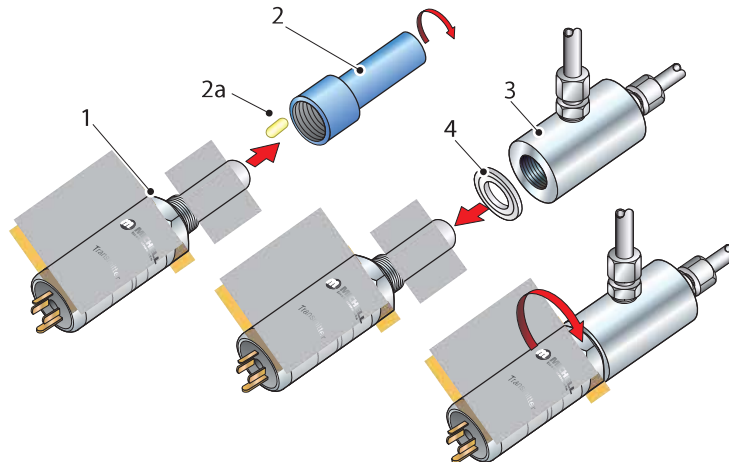

Figure 9 Transmitter Mounting – Sensor Block

### 2.3.5 Transmitter Mounting – Direct Pipeline Connection

The transmitter may be directly mounted into a pipe or duct, as shown in *Figure 10*.



**CAUTION: Do not mount the transmitter too close to the bottom of a bend where any condensate in the pipeline might collect and saturate the probe.**

The pipe or duct will require a thread to match the transmitter body thread. Fixing dimensions are shown in *Figure 10*. For circular pipework, to ensure the integrity of a gas tight seal, a mounting flange will be required on the pipework in order to provide a flat surface to seal against.



**The following procedure must be carried out by competent personnel.**

1. Ensure that the blue protective cover (and its desiccant capsule) has been removed from the tip of the transmitter.



**WARNING: Under no circumstances should the sensor guard be handled with the fingers.**

2. Fit a bonded seal (2) over the threaded part of the transmitter body.
3. Screw the transmitter (3) into the pipe (1). Tighten enough to obtain a gas tight seal. (Torque will depend upon the pipeline material.) **NOTE: Do not overtighten or the thread on the pipework may be stripped.**

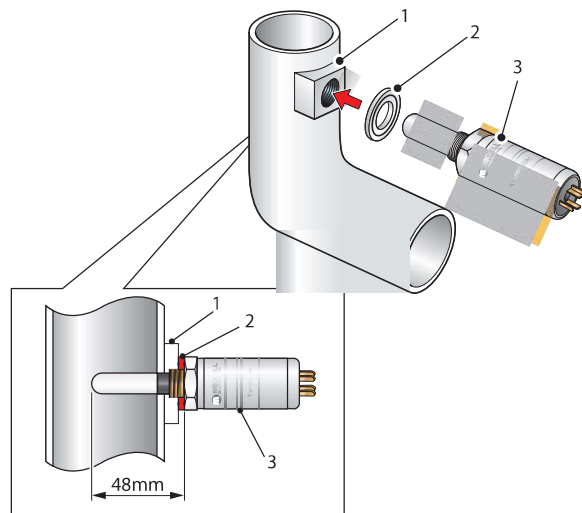

Figure 10 Transmitter Mounting – Pipe or Duct

## 2.3.6 Transmitter Mounting – With Additional Process Connection Adapter



**The following procedure must be carried out by a qualified installation engineer.**

To mount the adapter into the transmitter, proceed as follows (see *Figure 11*) :

1. Ensure that the protective cover (2), and its desiccant capsule (2a), have been removed from the tip of the transmitter.
2. Fit the bonded seal (3) over the threaded part of the transmitter body.
3. Screw the adapter (4) onto the threaded part of the transmitter and tighten to torque settings recommended in Section 4. **NOTE: Use the flats of the hexagonal nut and not the sensor body.**



**WARNING: Under no circumstances should the sensor guard be handled with the fingers.**

4. Screw the transmitter (1) with its seal (3) and adapter (4) into the sample block (see Section 2.3.4) or pipeline (see Section 2.3.5) and fully tighten using a wrench until the seal is fully compressed and to the following torque settings:

G 1/2" BSP	56 Nm (41.3 ft-lbs)
3/4" - 16 UNF `	40 Nm (29.5 ft-lbs)
1/2" NPT	Use a suitable sealant e.g. PTFE tape using correct taping procedures

**NOTE: Use the flats of the hexagonal nut and not the sensor body.**

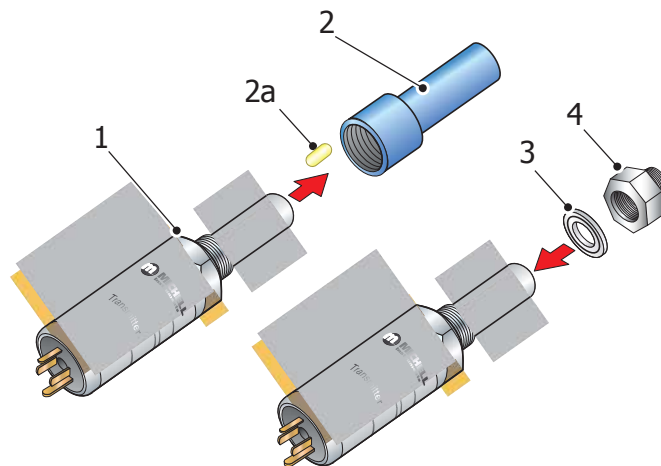

Figure 11 Transmitter Mounting with Adapter

## 3 MAINTENANCE

### 3.1 Maintenance and Calibration

Routine maintenance of the Easidew Transmitter is confined to regular re-calibration. For most applications, annual re-calibration ensures that the stated accuracy of the Easidew Transmitter is maintained.

Specialist calibration instrumentation is required to calibrate the transmitter and a true calibration can only be performed by exposure of the dew-point sensor to a reference gas of known dew point.

Calibration services are offered by Michell Instruments at their accredited calibration laboratories. All calibrations are traceable to national standards either via the National Physical Laboratory (UK) or the National Institute of Standards and Technology (USA).

The Easidew transmitter can be returned to Michell Instruments either directly or via the authorized distributor, for calibration.

Alternatively, Michell Instruments can provide an exchange transmitter. Prior to re-calibration, an exchange transmitter can be ordered from Michell Instruments or an authorized distributor.

Once the replacement transmitter and calibration certificate have been received, the original transmitter can be disconnected and the replacement transmitter fitted in its place. The original transmitter should be packed in its original packing, if possible, and returned to Michell Instruments, either directly or via an authorized agent.

#### Sensor Guard Replacement

The sensor is supplied with a white HMWPE guard (standard) or a stainless steel guard (if specified at time of order).

The sensor guard should be replaced if the surface shows any damage or signs of discoloration. When replacing a guard, make sure to wear clean disposable gloves, and handle by the threaded base section only.

Replacement HMWPE or stainless steel guards can be ordered from your Michell Instruments representative.

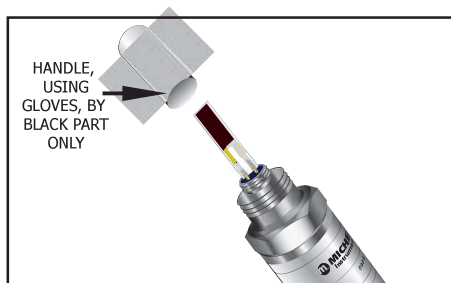

Figure 12 Replacement of HMWPE Guard

**Bonded Seal**

If the supplied bonded seal is damaged or lost, a pack of 5 replacement bonded seals can be obtained by your Michell Instruments representative.

**O-ring Seal**

If the supplied O-ring seal is damaged or lost a pack of 5 replacement O-ring seals can be obtained by contacting your Michell Instruments representative.



## 4 MEASUREMENT GUIDE

### 4.1 Sampling Considerations

There are two basic methods of measuring a sample with the Easidew Transmitter:

- In-situ measurements are made by placing the transmitter inside the environment to be measured.
- Extractive measurements are made by installing the sensor into a block within a sample handling system, and flowing the sample outside of the environment to be measured through this system.

Extractive measurements are recommended when the conditions in the environment to be measured are not conducive to making reliable measurements with the product.

Examples of such conditional limitations are:

- Excessive flow rate
- Presence of particulates matter
- Presence of entrained liquids
- Excessive sample temperature

The basic considerations for each measurement type are as follows:

## In-Situ

- Dew-Point Sensor Position** – will the sensor see an area of the environment that is representative of what you want to measure?

For example, if the sensor is to be mounted into a glove box, there are three different positions in which it could be installed – each giving a different measurement:

- Position A is on the purge inlet. In this position the sensor will confirm the dew point of the gas entering the glove box, but will not detect any leaks in the glove box itself, or any moisture released from the work piece.
- Position B is on the gas outlet. In this position the sensor will be exposed to the gas leaving the glove box, and will therefore be detecting any moisture which has entered into the system (e.g. ingress/leaks), or has been released by the work piece.
- Position C is in the glovebox itself, in this position the sensor will be only detecting any moisture in its immediate vicinity. Leaks not in close proximity to the measurement point may not be detected as this moisture could be drawn directly to the outlet.

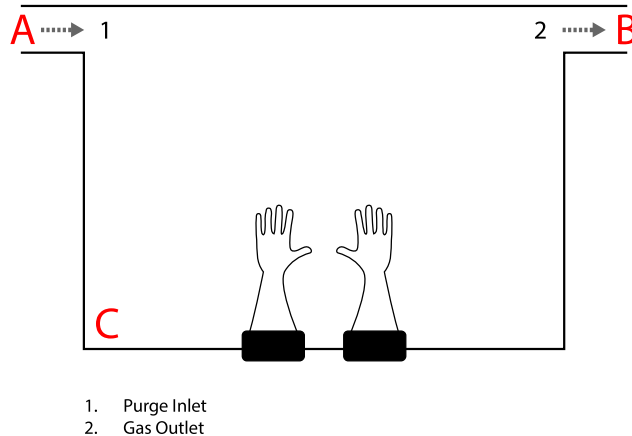

**Figure 13** *Installation Location*

If the transmitter is to be mounted directly into a pipe or duct, then consider that the installation point should not be too close to the bottom of a bend where oil or other condensate may collect.

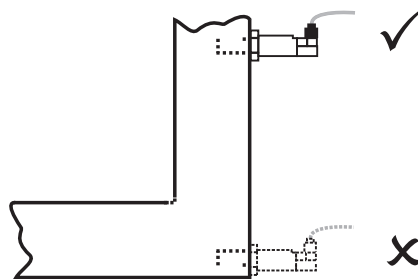

**Figure 14** *Installation Location*

- 2. Gas speed** – if you are planning on installing the sensor in a duct, consider how fast the sample gas is moving through it.

If the gas speed is very low, or occasionally static, then the moisture content through the length (and width, if it is more than a few cm across) of the duct is unlikely to be uniform.

Extremely high gas speeds can cause damage to the sensor. Direct insertion is not recommended in gas speeds in excess of 10m/s (32.8ft/s).

- 3. Particulates** – Particulates travelling at speed can cause severe and irreversible damage to the sensor. At low velocity they can cling to the sensor, reducing its' surface area, and therefore response speed.

The sensor is provided with a basic level of particulate protection in the form of a sintered guard; either HMWPE (10µm pore size) or Stainless Steel (80µm pore size). If the sample stream contains smaller particulates than this, or generally large amounts of dust; extractive measurement is recommended to accommodate proper in-line filtration.

- 4. Sample Temperature** – Although the Easidew can be operated at sample temperatures up to 60°C, it is advisable to keep the sample temperature as close to ambient, and as stable as possible to keep adsorption & desorption characteristics as consistent as possible (see Section 4.2, Sampling Hints, for more information).

### Extractive

If the sensor is to be mounted into a sample conditioning system, then the above points are still of relevance, but it is important to consider the extraction point itself – make sure that the chosen extraction point is representative of the process, i.e. that the sample of interest is flowing past the extraction point, and it is not being pulled from a dead volume.

## 4.2 Sampling Hints

Measurement of moisture content is a complex subject, but does not need to be difficult. This section aims to explain the common mistakes made in measurement situations, the causes of the problem, and how to avoid them. Mistakes and bad practices can cause the measurement to vary from the expectation; therefore a good sampling technique is crucial for accurate and reliable results.

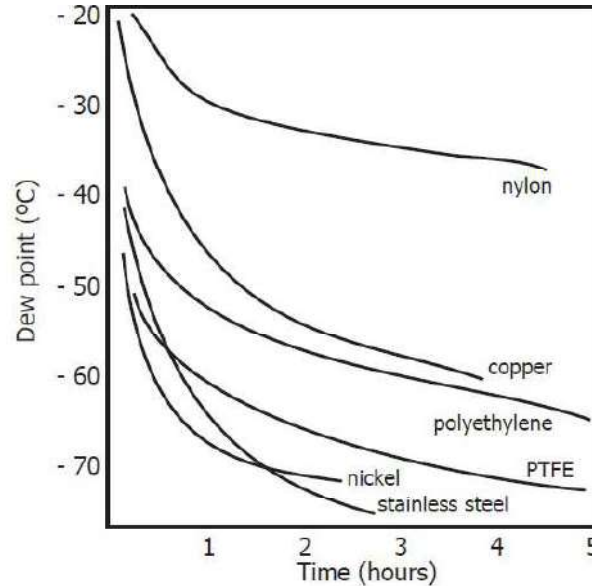

Figure 15 *Material Permeability Comparison*

All materials are permeable to water vapour, as the water molecule is extremely small compared to the structure of solids, even when compared to the crystalline structure of metals. The graph above shows the dew point inside tubing of different materials when purged with very dry gas, where the exterior of the tubing is in the ambient environment.

Many materials contain moisture as part of their structure, particularly organic materials (natural or synthetic), salts (or anything which contains them) and anything which has small pores. It is important to ensure that the materials used are suitable for the application.

If the partial water vapour pressure exerted on the outside of a compressed air line is higher than on the inside, the atmospheric water vapour will naturally push through the porous medium causing water to migrate into the pressurised air line. This effect is called transpiration.

### Adsorption and Desorption

Adsorption is the adhesion of atoms, ions, or molecules from a gas, liquid, or dissolved solid to the surface of a material, creating a film. The rate of adsorption is increased at higher pressures and lower temperatures.

Desorption is the release of a substance from or through the surface of a material. In constant environmental conditions, an adsorbed substance will remain on a surface almost indefinitely. However, as the temperature rises, so does the likelihood of desorption occurring.

In practical terms, as the temperature of the environment fluctuates, water molecules are adsorbed and desorbed from the internal surfaces of the sample tubing, causing small fluctuations in the measured dew point.

### Sample Tubing Length

The sample point should always be as close to the critical measurement point as possible, in order to obtain a truly representative measurement. The length of the sample line to the sensor or instrument should be as short as possible. Interconnection points and valves trap moisture, so using the simplest sampling arrangement possible will reduce the time it takes for the sample system to dry out when purged with dry gas.

Over a long tubing run, water will inevitably migrate into any line, and the effects of adsorption and desorption will become more apparent. It is clear from the graph shown above that the best materials to resist transpiration are stainless steel and PTFE.

### Trapped Moisture

Dead volumes (areas which are not in a direct flow path) in sample lines, hold onto water molecules which are slowly released into the passing gas; this results in increased purge and response times, and wetter than expected readings. Hygroscopic materials in filters, valves (e.g. rubber from pressure regulators) or any other parts of the system can also trap moisture.

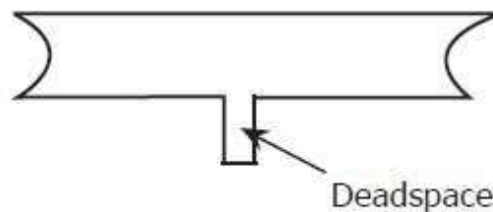

Figure 16 *Dead volume*

### Sample Conditioning

Sample conditioning is often necessary to avoid exposure of sensitive measuring components to liquids and other contaminants which may cause damage or affect the accuracy over time, depending on the measurement technology.

Particulate filters are used for removing dirt, rust, scale and any other solids that may be in a sample stream. For protection against liquids, a coalescing filter should be used.

The membrane filter is a more expensive but highly effective alternative to a coalescing filter. It provides protection from liquid droplets, and can even stop flow to the analyser completely when a large slug of liquid is encountered.

### Condensation and Leaks

Maintaining the temperature of the sample system tubing above the dew point of the sample is vital to prevent condensation. Any condensation invalidates the sampling process as it changes the water vapour content of the gas being measured. Condensed liquid can alter the humidity elsewhere by dripping or running to other locations where it may re-evaporate.

The integrity of all connections is also an important consideration, especially when sampling low dew points at an elevated pressure. If a small leak occurs in a high pressure line, gas will leak out but vortices at the leak point and a negative vapour pressure differential will also allow water vapour to contaminate the flow.

### **Flow Rates**

Theoretically flow rate has no direct effect on the measured moisture content, but in practice it can have unanticipated effects on response speed and accuracy. The optimal flow rate varies depending on the measurement technology, and can always be found in the instrument or sensor manual.

An inadequate flow rate can:

- Accentuate adsorption and desorption effects on the gas passing through the sampling system.
- Allow pockets of wet gas to remain undisturbed in a complex sampling system, which will then gradually be released into the sample flow.
- Increase the chance of contamination from back diffusion: ambient air that is wetter than the sample can flow from the exhaust back into the system. A longer exhaust (sometimes called a pigtail) can also help alleviate this problem.
- Slow the response of the sensor to changes in moisture content.

# Appendix A

## Technical Specifications

## Appendix A Technical Specifications

Product	Easidew, Easidew M12 and Easidew 34 Transmitter	Easidew I.S. Transmitter
<b>Performance Specifications</b>		
Measurement range	-110...+20 °C dew point; -100...+20 °C dew point; non standard ranges available on request	
Accuracy	±2°C dew point*	
Response time	5 mins to T95 (dry to wet)	
Repeatability	0.5 °C dew point	
Calibration	Traceable 13-point calibration certificate	
<b>Electrical Specifications</b>		
Output signal	4...20 mA (2-wire connection, current source); User configurable over range <b>Easidew M12:</b> Modbus RTU over RS485	
Output	Dew point or moisture content	
Analog output scaled range	<b>Dew point:</b> -110 up to +20°C; <b>Moisture content in gas:</b> 0 up to 3000 ppm <sub>v</sub>	
Supply voltage	12...28 V DC	
Load resistance	Max 250 Ω @ 14 V (500 Ω @ 24 V)	
Current consumption	23 mA max, depending on output signal	
Compliances	CE & UKCA	
UL approval	Approved	
<b>UL61010-1 &amp; CAN/CSA C22.2 No. 61010-1</b>		
<b>Operating Specifications</b>		
Operating temperature	-40...+60 °C	
Compensated temperature range	-20...+50 °C	
Storage Temperature	-40...+60 °C	
Operating pressure	45 MPa (450 barg) maximum	
Flow rate	1...5 Nl/min mounted in standard sampling block; 0...10 m/sec direct insertion	
<b>Mechanical Specifications</b>		
Ingress protection	IP66 in accordance with standard BS EN 60529:1992; NEMA 4 protection in accordance with standard NEMA 250-2003 <b>Easidew M12:</b> IP65	
Intrinsically safe area certificates	ATEX/UKCA: II 1 G Ex ia IIC T4 Ga (-20...+70 °C) IECEX: EX ia IIC T4 Ga (-20...+70 °C) TR CU@ 0Ex ia IIC T4 Ga (-20...+70 °C) cQPSus: Class I, Division 1, Groups A B C D, T4	
Oxygen service	<b>Optional: cleaned for enriched oxygen service</b>	
Housing material	316 stainless steel	
Dimensions	MiniDIN 43650 form C L=132 mm x ø45 mm (with connector cable) <b>Easidew M12:</b> M12 5 pin L = 155 mm x ø45 mm (with connector cable)	
Filter (sensor protection)	<b>Standard:</b> HDPE <10µm <b>Optional:</b> 316 stainless steel sintered guard <80µm	
Process connection	<b>Easidew:</b> 5/8" - 18 UNF <b>Easidew:</b> G1/2" BSPP <b>Easidew 34:</b> 3/4" - 16 UNF <b>Easidew M12:</b> 5/8" -18 UNF, 3/4" - 16 UNF, G1/2" BSP	
Weight	150 g	
Electrical connections	<b>Easidew:</b> MiniDIN 43650 form C <b>Easidew M12:</b> M12 5 Pin (A coded)	
Mating Electrical Connectors	Mating connector supplied as standard <b>Easidew M12:</b> optional 0.8, 2, 5 metre M12 A coded connector/cable available	
Diagnostic conditions (factory programmed)	<b>Condition</b> Sensor fault Under-range dew point Over-range dew point	<b>Output</b> 23 mA 4 mA 20 mA
Approved galvanic isolators	KFD2-CR-EX1.20200 KFD2-CR-EX1.30200 KFD0-CS-EX1.50P KFD0-CS-EX2.50P KFD2-STC4-EX1.H MTL5041 MTL5040	

NOTES \* Over Compensated Temperature Range



## Dimensions

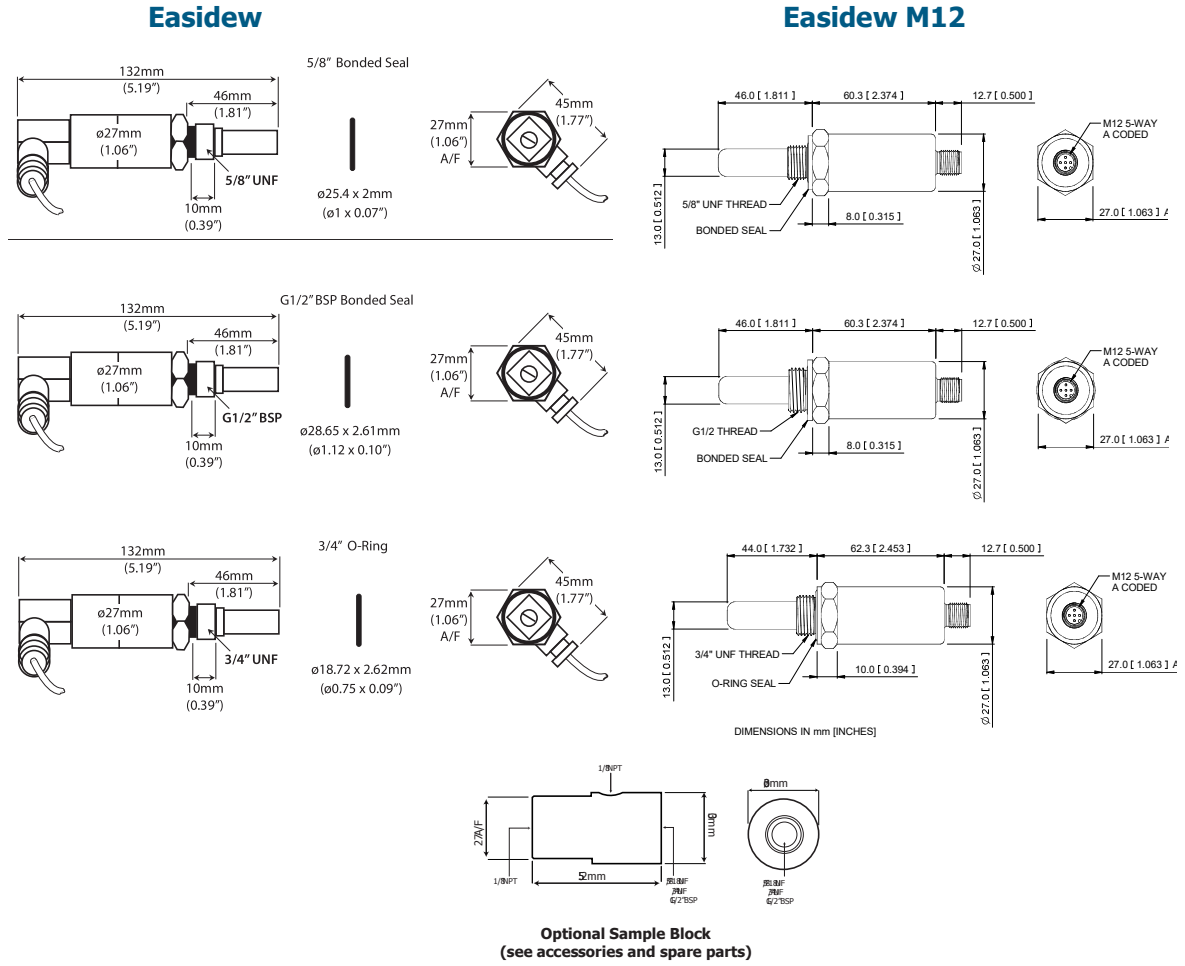

Figure 17 Dimensions – Easidew

# Appendix B

## Modbus Register Map

**Appendix B Modbus Register Map**

All the data values relating to the Easidew are stored in 16-bit wide holding registers. Registers can contain either measured or calculated values (dew-point, temperature, etc.), or configuration data (output settings).

**Modbus RTU Implementation**

This is a partial implementation of the Modbus RTU Standard with the following codes implemented:



Function Code	Description
3	Read Holding Register
6	Write Holding Register
16	Write Multiple Holding Registers

**Register Types**

Data Type	Description
uint16	16 bit unsigned integer, can contain options list e.g. 0 = Dew Point, 1 = Temperature.
int16	16 bit signed integer.
int32	32 bit signed integer, stored across 2 16 bit registers.
special	Refer to register description/comments for data structure.

**Serial Port Settings (RS485)**

9600 Baud Rate, 8 Data Bits, No Parity, 1 Stop Bit, No Flow Control

	<p>covering the basics of the Modbus protocol. Full descriptions of the function codes (FC03/FC06/FC16) can be found in the sidebar.</p>
	<p>online-hex-converter/ is an excellent resource for determining register types/byte order issues in raw received Modbus data.</p>

## Register Address

Dec	Hex	Access	Data Type	Description	Comment
0	0000	R/W	uint16	Instrument Modbus Address	1-255
3	0003	R	special	Status/Fault Indication	
				bit0, Sensor short circuit bit1, Sensor open circuit bit2, Thermistor short circuit bit3, Thermistor open circuit bit4, Sensor over range bit5, Sensor under range bit6, Thermistor over range bit7, Thermistor under range	
4	0004	R/W	special	Output Configuration	
				<u>Sensor fault output</u> bit0, 4mA bit1, 20mA bit2, 23mA bit3, 3mA <u>Dew-point under-range output</u> bit4, 4mA bit5, 20mA bit6, 23mA bit7, 3mA <u>Dew-point over-range output</u> bit8, 4mA bit9, 20mA bit10, 23mA bit11, 3mA <u>Output parameter</u> bit12, Temperature bit13, ppmV bit14, ppmW bit15, Natural gas	Only one bit can be set for each parameter, for example 'sensor fault' can be EITHER 4mA OR 20mA OR 23mA OR 3mA.  If bits 13 – 16 are not set, then the output will be dew point.  Natural gas parameter set in register 78.
8	0008	R	special	Transmitter Firmware Version	0x0100 = 1.0
10	000A	R/W	int16	Measurement Range Low	10x multiplier, i.e. -1000 = -100.0
11	000B	R/W	int16	Measurement Range High	10x multiplier, i.e. 200 = 20.0
15	000F	R	special	Sensor Batch Number	Batch 0xA123
16	0010	R	special	Sensor Serial Number	Serial 0x0001 Complete sensor serial would be A123-001
17	0011	R/W	special	Year of Calibration	0x2018 = 2018
18	0012	R/W	special	Month & Day of Calibration	0x317 = March 17th
54	0036	R/W	int16	Pressure value for ppmV (barg)	10x multiplier, i.e. 100 = 10.0

78	004E	R/W	special	Natural Gas Configuration & Precision Select	<u>Natural gas configuration</u> bit1, 0=IGT, 1=ISO bit2, lb/MMscf bit3, ppmV NG bit4, mg/m <sup>3</sup> NG <u>Precision Select</u> bit15, 0=1 Decimal Place, 1=4 Decimal Places
----	------	-----	---------	----------------------------------------------	-------------------------------------------------------------------------------------------------------------------------------------------------------------------------------------------------------

Register configuration in 1 decimal place precision mode

Dec	Hex	Access	Data Type	Description	Comment
1	0001	R	int16	Humidity Parameter	Default dew-point, selected with register 4 (and 78 for Natural gas)  10x multiplier, i.e. -811 = -81.1
2	0002	R	int16	Ambient Temperature	10x multiplier, i.e. 214 = 21.4

Register configuration in 4 decimal place precision mode

Dec	Hex	Access	Data Type	Description	Comment
1	0001	R	special	Humidity Parameter (Low Word)	Default dew-point, selected with register 4 (and 78 for Natural gas)  1000x multiplier, i.e. 14321 = 1.4321
2	0002	R	special	Humidity Parameter (High Word)	
7	0007	R	int16	Ambient Temperature	10x multiplier, i.e. 214 = 21.4

# Appendix C

## Quality, Recycling & Warranty Information

## Appendix C Quality, Recycling & Warranty Information

Michell Instruments is dedicated to complying to all relevant legislation and directives. Full information can be found on our website at:

This page contains information on the following directives:

- Anti-Facilitation of Tax Evasion Policy
- ATEX Directive
- Calibration Facilities
- Conflict Minerals
- FCC Statement
- Manufacturing Quality
- Modern Slavery Statement
- Pressure Equipment Directive
- REACH
- RoHS3
- WEEE2
- Recycling Policy
- Warranty and Returns

This information is also available in PDF format.

# Appendix D

## Return Document & Decontamination Declaration



## Appendix D Return Document &amp; Decontamination Declaration

## Decontamination Certificate

**IMPORTANT NOTE:** Please complete this form prior to this instrument, or any components, leaving your site and being returned to us, or, where applicable, prior to any work being carried out by a Michell engineer at your site.

Instrument			Serial Number	
Warranty Repair?	YES	NO	Original PO #	
Company Name			Contact Name	
Address				
Telephone #			E-mail address	
Reason for Return /Description of Fault:				
Has this equipment been exposed (internally or externally) to any of the following? Please circle (YES/NO) as applicable and provide details below				
Biohazards			YES	NO
Biological agents			YES	NO
Hazardous chemicals			YES	NO
Radioactive substances			YES	NO
Other hazards			YES	NO
Please provide details of any hazardous materials used with this equipment as indicated above (use continuation sheet if necessary)				
Your method of cleaning/decontamination				
Has the equipment been cleaned and decontaminated?			YES	NOT NECESSARY
Michell Instruments will not accept instruments that have been exposed to toxins, radio-activity or bio-hazardous materials. For most applications involving solvents, acidic, basic, flammable or toxic gases a simple purge with dry gas (dew point <-30°C) over 24 hours should be sufficient to decontaminate the unit prior to return. <b>Work will not be carried out on any unit that does not have a completed decontamination declaration.</b>				
<b>Decontamination Declaration</b>				
I declare that the information above is true and complete to the best of my knowledge, and it is safe for Michell personnel to service or repair the returned instrument.				
Name (Print)			Position	
Signature			Date	



1.800.561.8187

www.**itm**.com

information@itm.com