

Endurance™ 1R

2-Color Infrared Thermometer



Operating Instructions

Rev. E1 Sep 2015
59511

Contacts

Fluke Process Instruments

Fluke Process Instruments North America
Santa Cruz, CA USA
Tel: +1 800 227 8074 (USA and Canada, only)
+1 831 458 3900
solutions@flukeprocessinstruments.com

Fluke Process Instruments Europe
Berlin, Germany
Tel: +49 30 4 78 00 80
info@flukeprocessinstruments.de

Fluke Process Instruments China
Beijing, China
Tel: +8610 6438 4691
info@flukeprocessinstruments.cn

Worldwide Service

Fluke Process Instruments offers services, including repair and calibration. For more information, contact your local office or e-mail support@flukeprocessinstruments.com

www.flukeprocessinstruments.com

© Fluke Process Instruments
Specifications subject to change without notice.

Fluke Process Instruments

Made in Germany IP65

Model: E1RL-F2-V-0-0

Serial: 32130002

MAC: 00:1D:8D:20:00:11

Power Requirements: 20 - 48V  12W



WARRANTY

The manufacturer warrants this instrument to be free from defects in material and workmanship under normal use and service for the period of four years from date of purchase. This warranty extends only to the original purchaser. This warranty shall not apply to fuses, batteries, or any product which has been subject to misuse, neglect, accident, or abnormal conditions of operation.

In the event of failure of a product covered by this warranty, the manufacturer will repair the instrument when it is returned by the purchaser, freight prepaid, to an authorized Service Facility within the applicable warranty period, provided manufacturer's examination discloses to its satisfaction that the product was defective. The manufacturer may, at its option, replace the product in lieu of repair. With regard to any covered product returned within the applicable warranty period, repairs or replacement will be made without charge and with return freight paid by the manufacturer, unless the failure was caused by misuse, neglect, accident, or abnormal conditions of operation or storage, in which case repairs will be billed at a reasonable cost. In such a case, an estimate will be submitted before work is started, if requested.

THE FOREGOING WARRANTY IS IN LIEU OF ALL OTHER WARRANTIES, EXPRESSED OR IMPLIED, INCLUDING BUT NOT LIMITED TO ANY IMPLIED WARRANTY OF MERCHANTABILITY, FITNESS, OR ADEQUACY FOR ANY PARTICULAR PURPOSE OR USE. THE MANUFACTURER SHALL NOT BE LIABLE FOR ANY SPECIAL, INCIDENTAL OR CONSEQUENTIAL DAMAGES, WHETHER IN CONTRACT, TORT, OR OTHERWISE.

SOFTWARE WARRANTY

The manufacturer does not warrant that the software described herein will function properly in every hardware and software environment. This software may not work in combination with modified or emulated versions of Windows operating environments, memory-resident software, or on computers with inadequate memory. The manufacturer warrants that the program disk is free from defects in material and workmanship, assuming normal use, for a period of one year. Except for this warranty, the manufacturer makes no warranty or representation, either expressed or implied, with respect to this software or documentation, including its quality, performance, merchantability, or fitness for a particular purpose. As a result, this software and documentation are licensed "as is," and the licensee (i.e., the User) assumes the entire risk as to its quality and performance. The liability of the manufacturer under this warranty shall be limited to the amount paid by the User. In no event shall the manufacturer be liable for any costs including but not limited to those incurred as a result of lost profits or revenue, loss of use of the computer software, loss of data, the cost of substitute software, claims by third parties, or for other similar costs. The manufacturer's software and documentation are copyrighted with all rights reserved. It is illegal to make copies for another person.

Specifications subject to change without notice.



The device complies with the requirements of the European Directives.
EC – Directive 2004/108/EC (EMC)



Electromagnetic Compatibility Applies to use in Korea only. Class A Equipment (Industrial Broadcasting & Communication Equipment)
This product meets requirements for industrial (Class A) electromagnetic wave equipment and the seller or user should take notice of it. This equipment is intended for use in business environments and is not to be used in homes.

TABLE OF CONTENTS

1 SAFETY INSTRUCTIONS	7
2 PRODUCT DESCRIPTION	9
2.1 THEORY OF OPERATION FOR 2-COLOR SENSORS	10
2.1.1 <i>Partially Obscured Targets</i>	10
2.1.2 <i>Targets Smaller Than Field of View</i>	10
2.1.3 <i>Emissivity and 1-color (single wavelength) measurements</i>	11
2.1.4 <i>Slope (2-color ratio) measurements</i>	11
3 TECHNICAL DATA	12
3.1 MEASUREMENT SPECIFICATIONS.....	12
3.2 GENERAL SPECIFICATIONS.....	13
3.3 ELECTRICAL SPECIFICATIONS	14
3.4 DIMENSIONS.....	15
3.5 OPTICAL SPECIFICATIONS.....	16
3.6 SCOPE OF DELIVERY	17
4 ENVIRONMENT	18
4.1 AMBIENT TEMPERATURE	18
4.2 ATMOSPHERIC QUALITY	18
4.3 ELECTRICAL INTERFERENCE	18
5 INSTALLATION	19
5.1 MECHANICAL INSTALLATION	19
5.1.1 <i>Distance to Object</i>	19
5.1.2 <i>Sensor Placement (1-Color Mode)</i>	19
5.1.3 <i>Sensor Placement (2-Color Mode)</i>	20
5.1.4 <i>Viewing Angles</i>	21
5.1.5 <i>Aiming and Focusing</i>	22
5.2 ELECTRICAL INSTALLATION	23
5.2.1 <i>M16 12-Pin DIN Connector</i>	23
5.2.2 <i>M12 4-Socket LAN/Ethernet Connector</i>	24
5.2.3 <i>Accessory Cables and Terminal Block</i>	25
5.2.4 <i>Power Supply</i>	27
5.2.5 <i>Computer Interfacing via RS485 link</i>	27
5.2.6 <i>Addressing the Endurance sensor in a RS485 Multidrop Network</i>	28
6 OPERATION	29
6.1 CONTROL PANEL	29
6.1.1 <i>The Temperature Display (green 7-segment LED type)</i>	30
6.1.2 <i>The Screen / Menu Display</i>	30
6.1.3 <i>The Pointing Device Indicator LED (red)</i>	30
6.1.4 <i>The Status Indicator LED (green)</i>	30
6.1.5 <i>The four control elements (pushbuttons) of the control panel</i>	31
6.2 THE SELECTABLE SUBMENUS AND ASSOCIATED ENTRIES	32
6.2.1 <i>The INFORMATION MENU</i>	32

6.2.2 The CONFIGURATION MENU.....	32
6.2.3 The UNIT SETUP MENU.....	33
6.2.4 The INTERFACE MENU.....	33
6.2.5 The ANALOG MENU.....	33
6.3 TOTAL CONTROL PANEL (USER INTERFACE) STRUCTURE.....	34
7 SIGNAL POST PROCESSING DETAILS.....	35
7.1 AVERAGING.....	35
7.2 PEAK HOLD.....	35
7.3 VALLEY HOLD.....	36
7.4 SETPOINT.....	37
7.5 DEADBAND.....	37
7.6 OUTPUTS.....	38
7.6.1 Analog Output (current loop).....	38
7.6.2 Relay Outputs.....	38
7.6.3 Trigger.....	38
7.7 FACTORY DEFAULTS.....	39
8 OPTIONS.....	40
8.1 LASER SIGHTING.....	40
8.2 LED SIGHTING.....	41
8.3 VIDEO SIGHTING.....	41
8.4 AIR/WATER COOLED HOUSING.....	41
8.4.1 Avoidance of Condensation.....	43
9 ACCESSORIES.....	44
9.1 OVERVIEW.....	44
9.2 FIXED MOUNTING BRACKET.....	45
9.3 AIR PURGE COLLAR.....	45
9.4 POLARIZING FILTER END CAP.....	46
9.5 CABLES.....	47
9.6 INDUSTRIAL POWER SUPPLY.....	48
10 PROGRAMMING GUIDE.....	49
10.1 REMOTE VERSUS MANUAL CONSIDERATIONS.....	49
10.2 COMMAND STRUCTURE.....	49
10.3 TRANSFER MODES.....	50
10.3.1 Poll Mode.....	50
10.3.2 Burst Mode.....	50
10.4 COMMAND LIST.....	51
10.5 COMMAND EXAMPLES.....	53
11 MAINTENANCE.....	55
11.1 TROUBLESHOOTING MINOR PROBLEMS.....	55
11.2 FAIL-SAFE OPERATION.....	55
11.2.1 Fail-Safe Error Codes (displayed or transmitted via electrical interface).....	55
11.2.2 Analog Output (Current) values in dependence of Fail-Safe Error Codes.....	56
11.3 CLEANING THE LENS.....	58

11.4 CHANGING THE WINDOW	58
12 APPENDIX.....	59
12.1 DETERMINATION OF SLOPE (FOR 2 – COLOR OPERATION)	59
12.2 PERCENTAGE OF ALLOWED SIGNAL REDUCTION.....	59
12.3 DETERMINATION OF EMISSIVITY (FOR 1-COLOR OPERATION)	61
12.4 TYPICAL EMISSIVITY VALUES.....	61

1 Safety Instructions

This document contains important information, which should be kept at all times with the instrument during its operational life. Other users of this instrument should be given these instructions with the instrument. Eventual updates to this information must be added to the original document. The instrument can only be operated by trained personnel in accordance with these instructions and local safety regulations.

Acceptable Operation

This instrument is intended only for the measurement of temperature. The instrument is appropriate for continuous use. The instrument operates reliably in demanding conditions, such as in high environmental temperatures, as long as the documented technical specifications for all instrument components are adhered to. Compliance with the operating instructions is necessary to ensure the expected results.

Unacceptable Operation

The instrument should not be used for medical diagnosis.

Replacement Parts and Accessories

Use only original parts and accessories approved by the manufacturer. The use of other products can compromise the operation safety and functionality of the instrument.

Instrument Disposal



Disposal of old instruments should be handled according to professional and environmental regulations as electronic waste.

Operating Instructions

The following symbols are used to highlight essential safety information in the operation instructions:



Helpful information regarding the optimal use of the instrument.



Warnings concerning operation to avoid instrument damage and personal injury.



The instrument can be equipped with a Class 2 laser. Class 2 lasers shine only within the visible spectrum at an intensity of 1 mW. Looking directly into the laser beam can produce a slight, temporary blinding effect, but does not result in physical injury or damage to the eyes, even when the beam is magnified by optical aids. At any rate, closing the eye lids is encouraged when eye contact is made with the laser beam. Pay attention to possible reflections of the laser beam. The laser functions only to locate and mark surface measurement targets. Do not aim the laser at people or animals.















Pay particular attention to the following safety instructions.

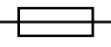

Use in 110/230 V~ electrical systems can result in electrical hazards and personal injury, if not properly protected. All instrument parts supplied by electricity must be covered to prevent physical contact and other hazards at all times.

Safety Instructions

General Symbols

	AC (Alternating Current)
	DC (Direct Current)
	Risk of danger. Important information. See manual.
	Hazardous voltage. Risk of electrical shock.
	Helpful information regarding the optimal use of the instrument.
	Earth ground
	Protective ground
	Fuse
	Normally-open (NO) relay
	Normally-closed (NC) relay
	Switch or relay contact
	DC power supply
	Conforms to European Union directive.
	Disposal of old instruments should be handled according to professional and environmental regulations as electronic waste.

2 Product Description

The Endurance 1R Series of instruments are 2-color infrared noncontact temperature measurement systems with variable focus, through-the-lens sighting, and parallax-free optics. They are energy transducers designed to measure accurately and repeatedly the amount of heat energy emitted from an object, and then convert that energy into a measurable electrical signal. Temperature measurements can be taken using either of the following modes:

- **1-color mode** – for standard temperature measurements. The 1-color mode is best for measuring the temperature of targets in areas where no sighting obstructions, either solid or gaseous, exist. The 1-color mode is also best where the target completely fills the measurement spot.
- **2-color mode** – temperatures are determined from the ratio of two separate and overlapping infrared bands. The 2-color mode is best for measuring the temperature of targets that are partially obscured (either intermittently or permanently) by other objects, openings, screens, or viewing windows that reduce energy, and by dirt, smoke, or steam in the atmosphere. The 2-color mode can also be used on targets that do not completely fill the measurement spot, provided the background is much cooler than the target.

Each model operates as an integrated temperature measurement subsystem consisting of optical elements, spectral filters, detector, digital electronics and an IP65 (NEMA-4) rated housing. Each is built to operate on a 100 percent duty cycle in industrial environments. Various output types are offered for easy integration into industrial monitoring and control environments.

Model	Temperature Range	2C 95% Attenuation Minimum Temperature	Optical Resolution (Nominal)
1RL	550 to 1800 °C (1022 to 3272°F) in 1C mode 600 to 1800 °C (1112 to 3272°F) in 2C mode	800°C (1472°F)	100:1
1RH	1000 to 3200°C (1832 to 5792°F)	1300°C (2372°F)	150:1

Focal Range F1 = Close Focus 300 mm to 600 mm (12" to 24")
 F2 = Standard Focus 600 mm to ∞ (24" to ∞)

Table 1: Models



For the percentage of allowed signal reduction at temperatures below the minimum temperature (95% attenuation) as shown above, refer to the 12 Appendix, page 59.

Product Description

2.1 Theory of Operation for 2-Color Sensors

Two-color ratio technology makes possible accurate and repeatable temperature measurements that are free from dependence on absolute radiated energy values. In use, a 2-color sensor determines temperature from the ratio of the radiated energies in two separate wavelength bands (colors).

The benefits of 2-color sensors are that accurate measurements can be made under the following conditions:

- When the field of view to the target is partially blocked or obscured.
- When the target is smaller than the sensor's field of view.
- When the target emissivity is low or changing by the same factor in both wavelength bands.

Another benefit is that 2-color sensors measure closer to the highest temperature within the measured spot (spatial peak picking) instead of an average temperature. A 2-color sensor can be mounted farther away, even if the target does not fill the resulting spot size. The convenience is that you are not forced to install the sensor at some specific distance based upon target size and the sensor's optical resolution.

2.1.1 Partially Obscured Targets

The radiated energy from a target is, in most cases, equally reduced when objects or atmospheric materials block some portion of the optical field of view. It follows that the ratio of the energies is unaffected, and thus the measured temperatures remain accurate. A 2-color sensor is better than a 1-color sensor in the following conditions:

- Sighting paths are partially blocked (either intermittently or permanently).
- Dirt, smoke, or steam is in the atmosphere between the sensor and target.
- Measurements are made through items or areas that reduce emitted energy, such as grills, screens, small openings, or channels.
- Measurements are made through a viewing window that has unpredictable and changing infrared transmission due to accumulating dirt and/or moisture on the window surface.
- The sensor itself is subject to dirt and/or moisture accumulating on the lens surface.



1-color sensors see polluted atmosphere and dirty windows and lenses as a reduction in energy and give much lower than actual temperature readings!

2.1.2 Targets Smaller Than Field of View

When a target is not large enough to fill the field of view, or if the target is moving within the field of view, radiated energies are equally reduced, but the ratio of the energies is unaffected and measured temperatures remain accurate. This remains true as long as the background temperature is much lower than the target's. The following examples show where 2-color sensors can be used when targets are smaller than the field of view:

- Measuring wire or rod — often too narrow for field of view or moving or vibrating unpredictably. It is much easier to obtain accurate results because sighting is less critical with two-color sensors.
- Measuring molten glass streams — often narrow and difficult to sight consistently with single-wavelength sensors.

2.1.3 Emissivity and 1-color (single wavelength) measurements

Emissivity is a calculated ratio of infrared energy emitted by an object to the energy emitted by a blackbody at the same temperature (a perfect radiator has an emissivity of 1.00). The emissivity is preset at 1.00. For information on determining an unknown emissivity, and for sample emissivities, refer to the appendix of this manual.

When target emissivity is uncertain or changing, a 2-color sensor can be more accurate than a 1-color instrument as long as the emissivity changes by the same factor in both wavelength bands. Accurate measurement results are dependent on the application and the type of material being measured. The emissivity of all real objects changes with wavelength and temperature, at varying degrees, depending on the material. To determine how to use 2-color sensors with your application when uncertain or changing emissivities are a factor, please contact our sales representative or technical support department.

2.1.4 Slope (2-color ratio) measurements

The slope is the quotient of the emissivities based on the narrow and the wide spectral range (first and second wavelength). The slope is preset at the factory at 1.000.

For information on determining an unknown slope, and for sample slopes, refer to the appendix of this manual.



The slope is the deciding parameter for measurements in 2-color mode! The emissivity affects only measurements in 1-color mode.

Technical Data

3 Technical Data

3.1 Measurement Specifications

Temperature Range

1RL 550 to 1800 °C (1022 to 3272°F) in 1C mode
600 to 1800 °C (1112 to 3272°F) in 2C mode

1RH 1000 to 3200°C (1832 to 5792°F)*
*(Indication only from 3000 to 3200°C (5432 to 5792°F))

Spectral Band Measured

1-color band 0.75 to 1.1 μm (1.0 μm nominal)
2-color bands 0.75 to 1.1 μm, 0.95 to 1.1 μm

System Accuracy

± (0.5% T_{meas} + 2°C), T_{meas} in °C *
*At 23°C ±5°C (73°F ±9°F), emissivity/slope = 1.0, no attenuation

Repeatability

±0.3% full scale

Temperature Resolution - Display and Outputs

1RL and 1RH 0.1°C (0.2°F)

Response Time (95% Response)

10 ms for signal to reach 95% of final temperature

Temperature Coefficient

0.03% full scale change per 1°C change in ambient temperature

Emissivity (1-color)

0.10 to 1.10, digitally adjustable in increments of 0.01

Slope (2-color)

0.850 to 1.150, digitally adjustable in increments of 0.001

Signal Processing

Peak hold or Averaging

Noise Equivalent Temperature (NET)

1°C peak to peak, target emissivity of 1.00, unobscured target
3°C peak to peak, for all specified attenuation conditions

Peak Hold Range

0.1 to 299.9 s (300 s = ∞)

Averaging Range

0.1 to 299.9 s (300 s = ∞)

Warm Up Period

15 minutes

3.2 General Specifications

Control Panel (User Interface)	Upper Display: Green 7-segment, 4 digits LED type for displaying the measured object temperature and error codes Lower Display: Green/Red background illuminated graphics display type. Resolution is 32 * 136 pixels to display 2 text lines of about 16 characters per line. It is the main screen/menu display, which shows all information and configuration topics. 2 individual (red/green) LED's to indicate the instrument status and Laser/LED/Video on/off. 4 individual control pushbuttons, to walk through the menu structure and to enter setup values
Environmental Rating	IP65 (NEMA-4)
Ambient Temperature	
Without cooling	0 to 65°C (32°F to 149°F)
With air cooling	0 to 120°C (32°F to 250°F)
With water cooling	0 to 175°C (32°F to 350°F)
With ThermoJacket	0 to 315°C (32°F to 600°F)
Storage Temperature	
Electronics Housing	-20 to 70°C (-4°F to 158°F)
Relative Humidity	10 to 95%, non-condensing at 22°C to 43°C (72°F to 110°F)
EMC	EN 61326-1:2006
Safety	EN 60825-1:2008-05 FDA laser safety compliant
Mechanical Shock	MIL-STD-810G (IEC 68-2-27), 5 G, 11 msec duration, 3 axis
Vibration	MIL-STD-810G (IEC 68-2-6), 2 G, 10 to 150 Hz 3 axis
Warm up Period	15 minutes
Weight (incl. nut & mnt. bracket)	
Endurance sensor	1551g (3.42 lbs)
With air/water-cooled housing	2688g (5.93 lbs)
Housing Material	
Stainless steel	Mat.-No.: 1.4305, Mat.-Name.: X8CrNiS18-9
Fail-Safe	Full or low scale, depending upon system failure. See section 11.2 Fail-Safe Operation, page 55.

Technical Data

3.3 Electrical Specifications

Power Supply	24 VDC nominal, 20 to 48 VDC allowed, max. 12W
Electrical Interfaces	all interfaces and I/O's are galvanically isolated
Outputs	
Analog (+mA Out, -mA Out)	0 - 20 mA, 4 - 20 mA, active output, 16 bit resolution max current loop impedance: 500 Ω
Digital RS485 (A, B)	Network compatible up to 32 sensors (2-wire half duplex) Data format: 8 bit, no parity, 1 stop bit Data rate: 1200, 2400, 9600, 19200, 38400 (default), 57600, 115200 Bit/s 2-wire half duplex, multidrop line capability
Alarm Output Relay (Relay, Relay)	Potential-free contact of a solid state relay, max. 48 V, 300 mA Contact behavior is settable via user interface between (NO = Normally Open, NC = Normally Close, PO = Permanently Open, PC = Permanently Close)

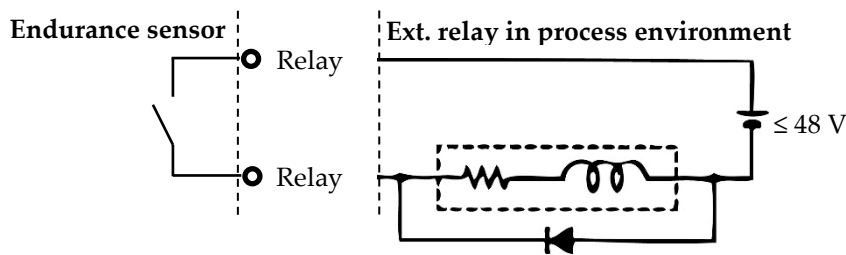

Figure 1: Spike Voltage Limitation for the Alarm Relay

Input	
External Trigger/Hold	Digital low/high, trigger for resetting AVERAGE, PEAK HOLD or VALLEY HOLD to restart signal processing

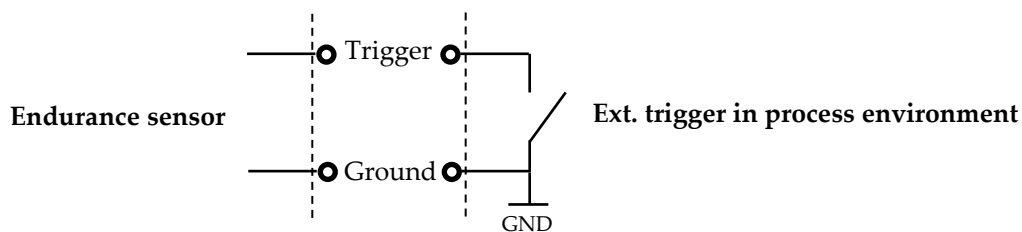

Figure 2: External Trigger/Hold Wiring

Network	4-Wire 10/100 Mbit LAN/Ethernet with "Power over Ethernet" capability to power the Endurance device via the interface. Please refer for the correct wiring to PoE standard IEEE 802.3af, mode A, 10/100 Mbit mixed DC & data.
----------------	---

3.4 Dimensions

The following illustrations show dimensions of a standard sensor, see Figure 3, a sensor with the air/water-cooled housing option, see Figure 4, and the adjustable bracket, see Figure 5.

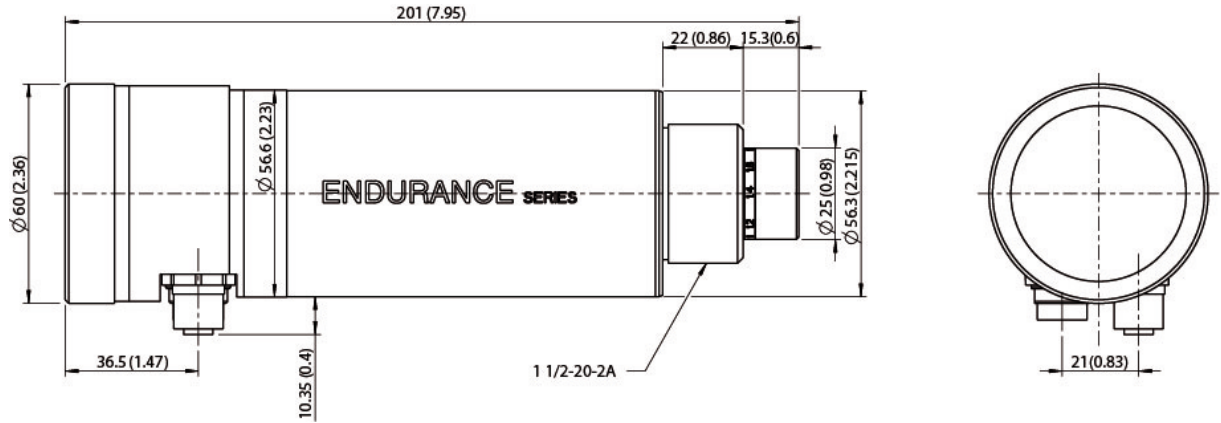

Figure 3: Dimensions of Endurance Head

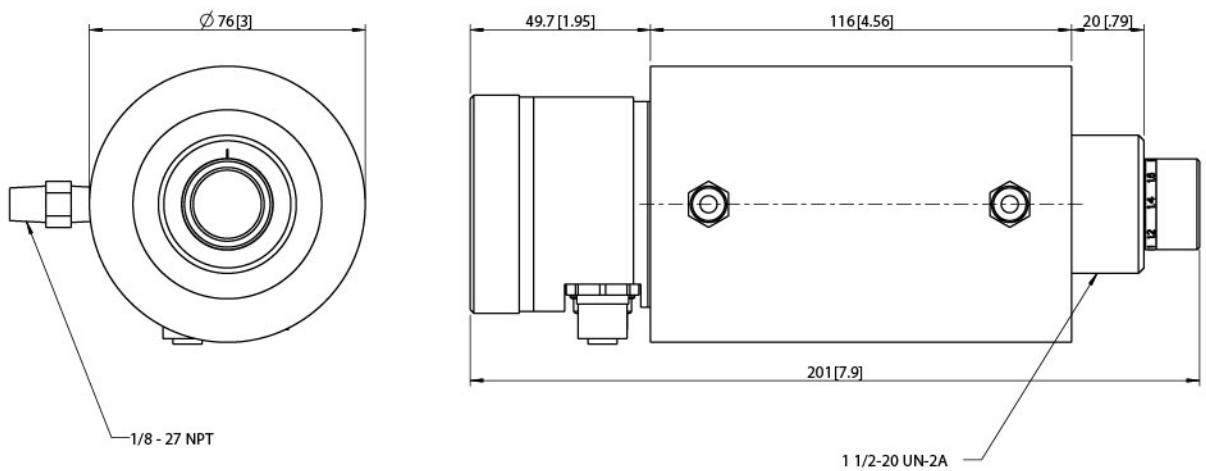

Figure 4: Endurance Head with Air/Water-Cooled Housing Option

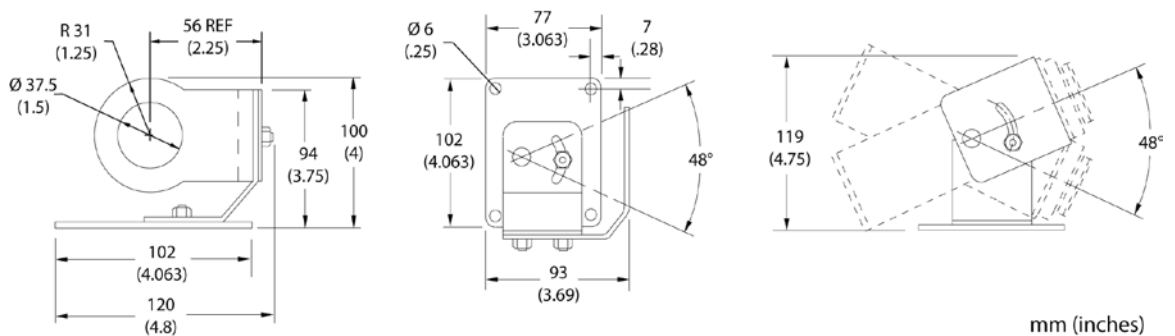

Figure 5: Adjustable Bracket

Technical Data

3.5 Optical Specifications

Optical Resolution D:S (assumes 95% energy at the focus point)

EN1RL	100:1
EN1RH	150:1

Because the sensor has variable focus, through-the-lens sighting, and parallax-free optics, it can be mounted almost anywhere. Adjustable focus distance range varies by model:

- F1 (Close Focus) models can be focused from 300 mm to 600 mm (12 to 24")
- F2 (Standard Variable Focus) models can be focused from 600 mm to infinity (24" to infinity)

For 1-color temperature measurements make sure the target completely fills the measurement spot. The spot size for any distance, when the unit is properly focused at that distance, can be determined using the following formula and Figure 6.

Divide the distance (D, in Figure 6) by the D:S specification. For example, if the D:S specification is 150:1, and the sensor is 2000 millimeters (80 inches) from the target, divide 2000 by 150 (80 by 150), resulting in a target spot size of which gives you a target spot size of 13.3 mm (0.5 in).

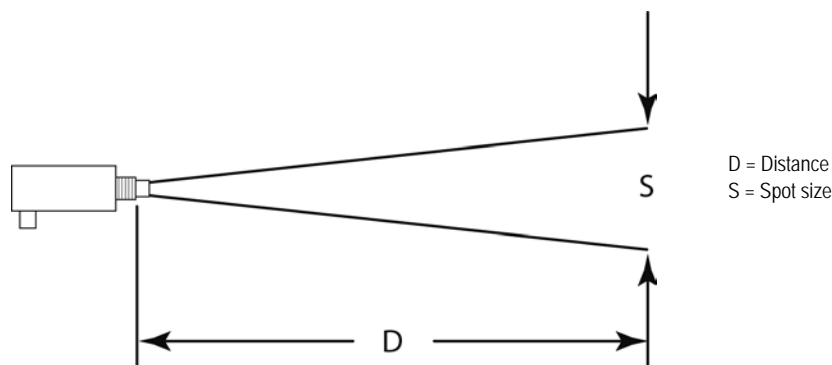

Figure 6: Spot Size Chart



The spot size calculated using this method is valid only at the focus distance. Spot sizes out of focus distances will vary from the rule.

3.6 Scope of Delivery

The ENDURANCE delivery includes the following:

- Endurance 1R 2-Color Infrared Thermometer
- Fixed mounting bracket (E-FB) with mounting nut
- End cap for display
- Mini-DVD with Endurance SW, Operating Instructions and Quickstart guide
- Printed Quickstart guide

Accessories, which have to be ordered separately!



- **Both Endurance communication and supply interface cables, a 12-wire a M16 12-socket DIN connector and a 4-wire LAN/Ethernet cable, selected for the needed temperature range**
- **The Endurance series terminal block with specific signal/wire assignment**
- **PoE (Power over Ethernet) injector to supply the Endurance device via the LAN/Ethernet cable**

Environment

4 Environment

Sensor location and configuration depends on the application. Before deciding on a location, you need to be aware of the ambient temperature of the location, the atmospheric quality of the location (especially for 1-color temperature measurements), and the possible electromagnetic interference in that location. If you plan to use air purging, you need to have an air connection available. Also, wiring and conduit runs must be considered, including computer wiring and connections, if used. The following subsections cover topics to consider before you install the sensor.

4.1 Ambient Temperature

The sensing head is designed to operate in ambient temperatures between 0°C (32°F) and 65°C (149°F). The internal ambient temperature can vary from 10°C (50°F) to 72°C (162°F). Internal temperatures outside this range will cause a failsafe error. In ambient conditions above 65°C (149°F), an optional air/water cooled housing is available to extend the operating range to 120°C (250°F) with air cooling, or 175°C (350°F) with water cooling. When using the water cooled housing, it is strongly recommended to also use the air purge collar to avoid condensation on the lens. In ambient conditions up to 315°C (600°F), the ThermoJacket accessory should be used.

When using air or water cooling with air purging, make sure air and water supplies are installed before proceeding with the sensor installation.

Water and air temperatures for cooling should be 15-30°C (60-86°F) for best performance. Chilled water or air below 10°C (50°F) is not recommended. For air purging or air cooling, clean (filtered) or “instrument” air is recommended.

4.2 Atmospheric Quality

Smoke, fumes, dust, and other contaminants in the air, as well as a dirty lens are generally not a problem when using the 2-color mode (as long as the attenuation is equal in both spectral bands). However, if the lens gets too dirty, it cannot detect enough infrared energy to measure accurately, and the instrument will indicate a failure. It is good practice to always keep the lens clean. The Air Purge Collar helps keep contaminants from building up on the lens.

If you use air purging, make sure an air supply with the correct air pressure is installed before proceeding with the sensor installation.

4.3 Electrical Interference

To minimize electrical or electromagnetic interference or “noise” be aware of the following:

- Mount the electronics enclosure as far away as possible from potential sources of electrical interference such as motorized equipment producing large step load changes.
- Use shielded wire for all input and output connections.
- Make sure the shield wire from the electronics to terminal block cable is earth grounded.
- For additional protection, use conduit for the external connections. Solid conduit is better than flexible conduit in high noise environments.
- Do not run AC power for other equipment in the same conduit.

5 Installation

5.1 Mechanical Installation

After all preparations are complete, you can install the sensor.

How you anchor the sensor depends on the type of surface and the type of bracket you are using. As noted before, all sensors, whether standard or with the air/water-cooled housing option, are supplied with an adjustable bracket and mounting nut. You can also mount the sensor through a hole, on a bracket of your own design, or on one of the other available mounting accessories, see section 9 Accessories, page 44. If you are installing the sensor in a ThermoJacket accessory, you should use the appropriate mounting device. (Refer to the ThermoJacket manual for further details.) If you do not have the focusing tool accessory, the sensor must be focused before mounting inside a ThermoJacket or before attaching an air purge collar.

5.1.1 Distance to Object

Sensor placement can be varied to suit the application. The following sections show sensor placement and the various conditions where 2-color temperature measurements can be taken.



When installing the sensor, check for any high-intensity discharge lamps or heaters that may be in the field of view (either background or reflected on a shiny target)! Reflected heat sources can cause a sensor to give erroneous readings.

5.1.2 Sensor Placement (1-Color Mode)

Sensor placement for one-color temperature measurements is more critical than two-color measurements. The sensor must have a clear view of the target. There can be no obstructions on the lens, window, or in the atmosphere. The distance from the target can be anywhere beyond the minimum requirements, as long as the target completely fills the field of view. The following figure illustrates proper placement when using the one-color mode.

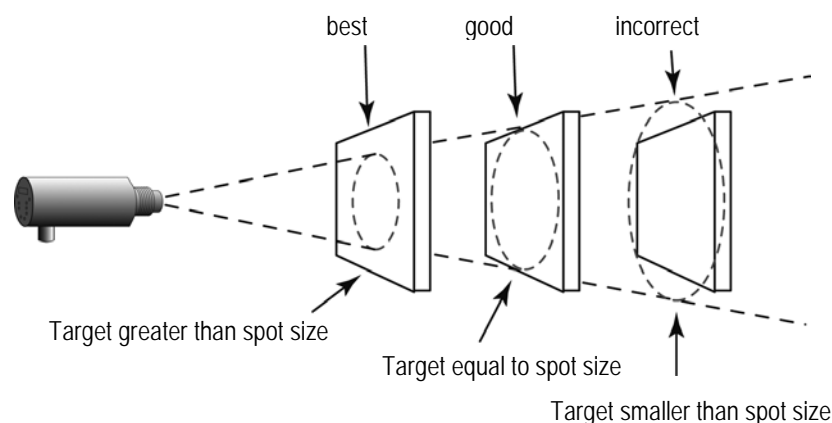

Figure 7: Proper Sensor Placement in 1-Color Mode

Installation

5.1.3 Sensor Placement (2-Color Mode)

The following figure shows head placement under various conditions where two-color temperature measurements can be taken. Note, however, that if the sensor signal is reduced more than 95% (including emissivity and obscuration of the target), the sensor accuracy also degrades.

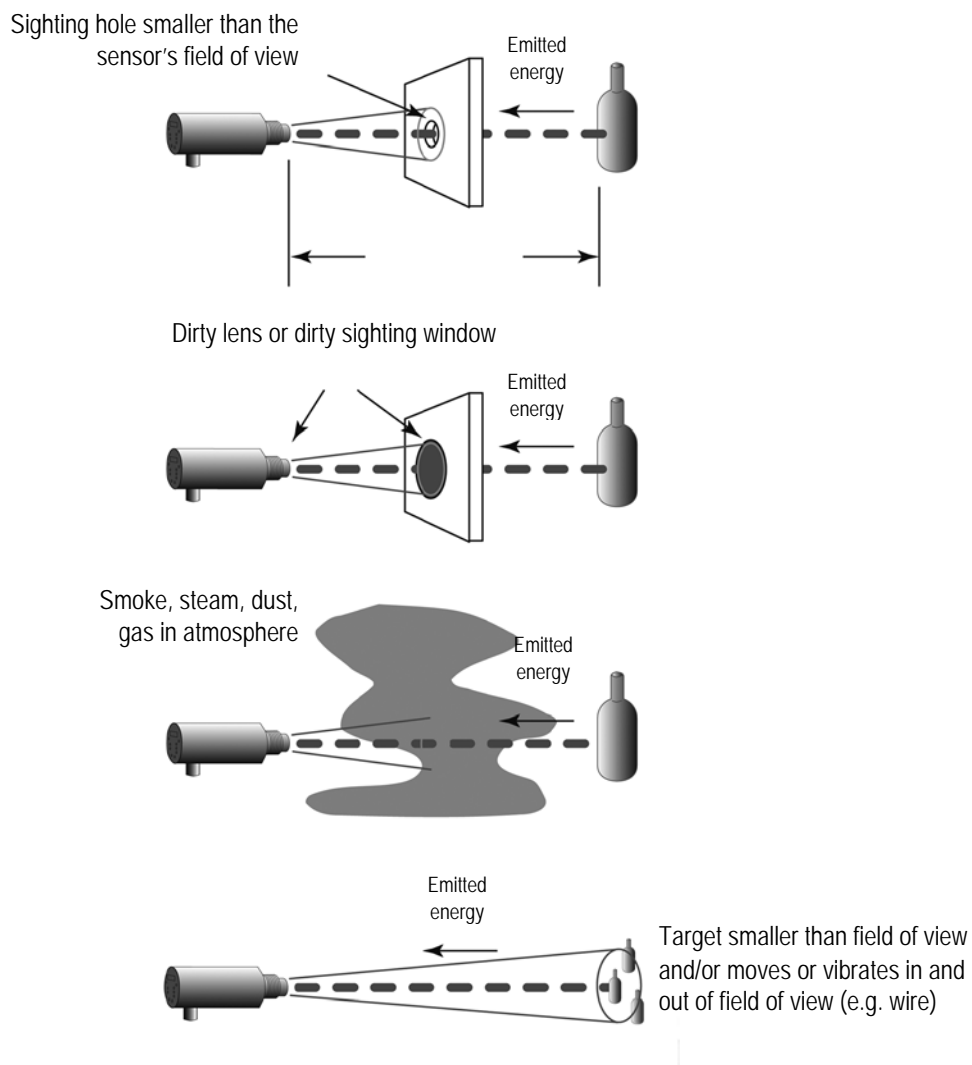

Figure 8: Sensor Placement in 2-Color Mode

5.1.4 Viewing Angles

The sensor can be placed at any angle from the target up to 30° for one-color mode, or 45° for two-color mode.

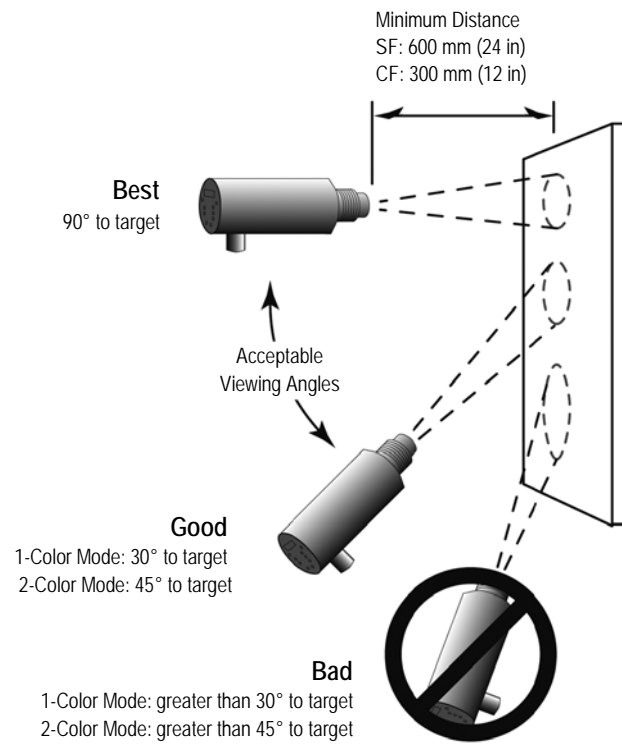

Figure 9: Acceptable Sensor Viewing Angles

Installation

5.1.5 Aiming and Focusing

Once you have the sensor in place, you need to aim and focus it on the target. To aim and focus the sensor, complete the following:

1. Loosen the nuts or bolts of the mounting base. (This can be either a factory-supplied accessory or customer-supplied base.)
2. Look through the eyepiece and position the sensor so the target is centered as much as possible in the middle of the reticle, see Figure 10. (Note that the target appears upside down.)
3. Turn the lens holder clockwise or counter-clockwise until the target is in focus. You can tell the lens is focused correctly by moving your eye from side to side while looking through the eyepiece. The target should not move with respect to the reticle. If it does, keep adjusting the focus until no apparent motion is observed.
4. Check again to be sure the target is still centered, and secure the mounting base. Focusing is complete.

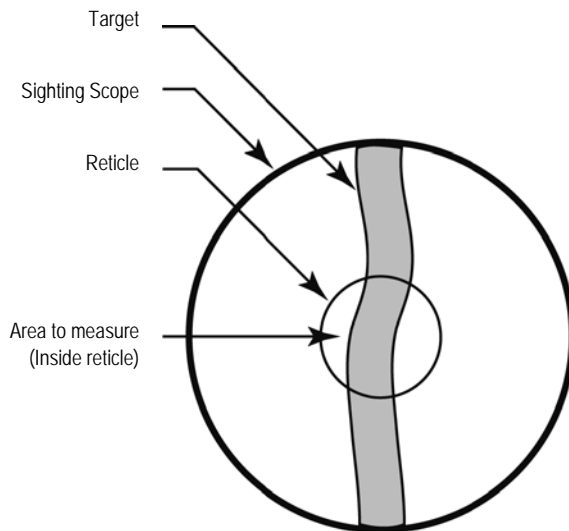

Figure 10: Sensor Eyepiece and Reticle



When focusing the sensor, do not depend on the clarity of the image through the eyepiece to determine the focus. Use the “move the eye” technique described in step 3 above. If the desired focus distance is known in advance, this focusing can be conveniently done in the office environment before installation.

5.2 Electrical Installation

The Endurance 1R infrared thermometer is equipped with two IP67 protected connector sockets. The M16 12-pin DIN connector houses a RS485 interface, trigger input, relay contact, current output and 24V power supply wires. The M12 4-socket connector houses a 100Mbit/s LAN/Ethernet link with integrated Power over Ethernet (PoE).

Endurance 1R is able to communicate via both integrated interfaces (LAN/Ethernet, RS485). It is possible to use the interfaces simultaneously!

5.2.1 M16 12-Pin DIN Connector

If you need to wire a new M16 12-socket DIN connector or rewire a supplied accessory cable connector, refer to the following illustration and table for the wiring layout.

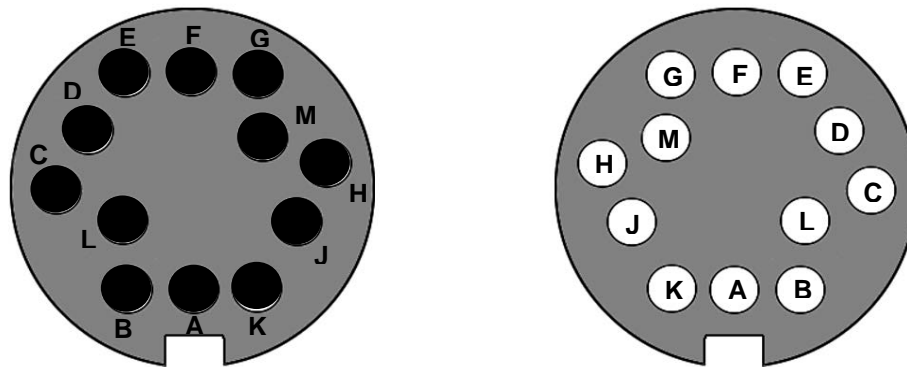

Figure 11: M16 12-Pin at the Endurance 1R (left) and the corresponding cable socket (right)

Pin	Color	Description
A	Black*	A
B	White*	B
C	Grey*	Not Connected
D	Purple*	Not Connected
E	White/Drain	Shield
F	Yellow	Trigger
G	Orange	Relay
H	Blue	Relay
J	Green	+ mA Out
K	Brown	- mA Out
L	Black	Power Ground
M	Red	+ 24 VDC

Note: Twisted Pairs* A/B and C/D

Figure 12: M16 DIN Connector signal assignment

Installation

5.2.2 M12 4-Socket LAN/Ethernet Connector

The LAN/Ethernet connector on Endurance 1R side is a M12 4-socket connector type, D-coded, suited for industrial Ethernet with IP67 protection rate and a screw retention feature. Via the LAN/Ethernet connector the Endurance 1R device can also be powered as a PD (Powered Device) by a PSE (Power Sourcing Equipment) in a PoE (Power over Ethernet) mode. In such operation mode a PoE injector or a PoE switch is needed. Refer to PoE standard IEEE 802.3af, mode A, 10/100 Mbit mixed DC & data.

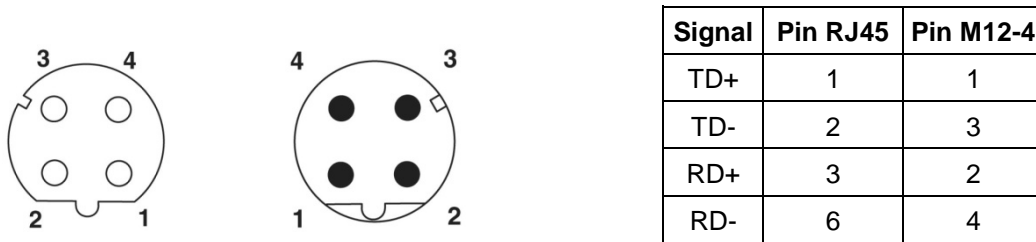

Figure 13: M12 Socket at the Endurance 1R (left) and the corresponding cable plug (right)

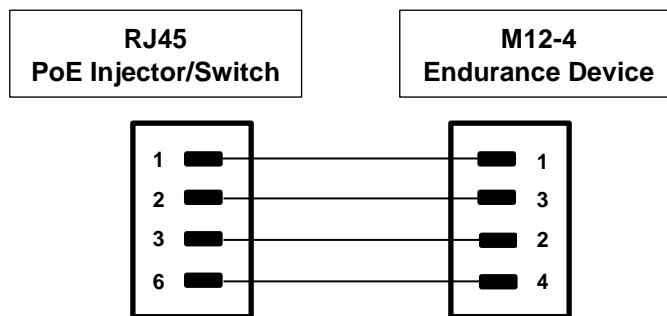

Figure 14: Ethernet Cable with M12 Plug and RJ45 Connector

5.2.3 Accessory Cables and Terminal Block

As accessories for the Endurance 1R devices there are two different communication cables and a specific terminal block available. Both sensor cables can be ordered in several cable lengths and two different ambient temperature ratings.



The sensor head is rated NEMA-4 (IEC 529, IP65).
Endcap must be securely installed to maintain proper sealing.



To prevent possible electrical shock, fire, or personal injury make sure that the sensor is grounded before use.

5.2.3.1 M16 12-Conductor shielded cable

The 12-conductor shielded connecting cable is used to wire all the fundamental inputs and outputs like RS485 interface, trigger input, relay contact, current input, current output and 24V power supply wires to the Endurance 1R sensor. The cable is equipped with an IP67 rated M16 12-socket DIN connector at one end and colored wires with cable end sleeves at the counter side.

See below the colored wire to signal assignments, which are identical to the specific terminal block labeling. For more cable details, see section 9.5 of this manual

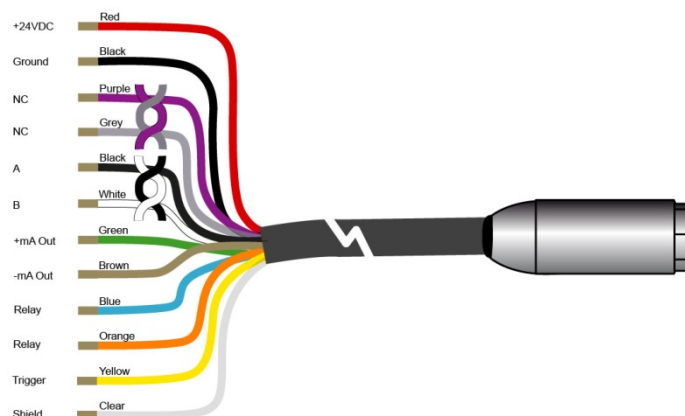

Figure 15

gnments



If you cut the cable to shorten it, notice that both sets of twisted-pair wires have drain wires inside their insulation. These drain wires (and the white wire that is not part of the twisted pair) must be connected to the terminal labeled CLEAR or SHIELD.

Installation



- Longer cables are available from the factory.
- Limit power cables to 60 m (200 ft) or less. RS485 cables can be extended up to 1200 m (4000 ft).
- Avoid installing the sensor cable in noisy electrical environments such as around electrical motors, switch gear, or induction heaters.

5.2.3.2 M12 4-Conductor shielded cable

The 4-conductor shielded connecting cable is used to link the Endurance 1R device to a LAN/Ethernet device. A standardized cable, equipped with a M12 4-pin connector type, D-coded, suited for industrial Ethernet with IP67 protection rate and a screw retention feature on one side and a RJ45 connector type on the counter side is used. Via the 4-conductor cable the Endurance 1R device can also be powered as a PD (Powered Device) by a PSE (Power Sourcing Equipment) in a PoE (Power over Ethernet) mode. Refer to PoE standard IEEE 802.3af, mode A, 10/100 Mbit mixed DC & data.



Figure 16: M12 4-Conductor shielded cable with RJ45 on counter side

5.2.3.3 Endurance 1R specific terminal block

To connect the Endurance 1R device via the 12-conductor shielded cable to the industrial process world, an Endurance 1R specific terminal block is available. Attach the color coded sensor cable wires to the color coded side of the terminal block.

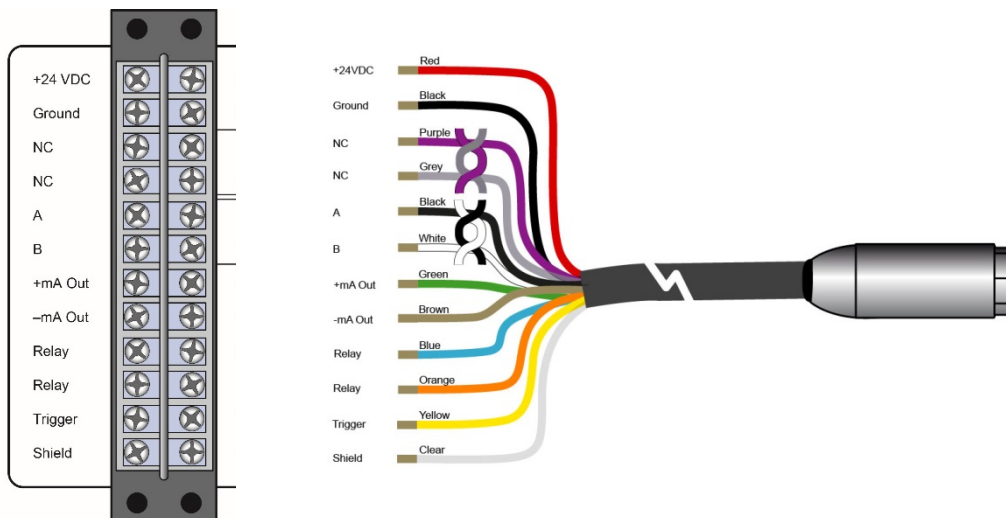

Figure 17: Endurance 1R labeled terminal block

5.2.4 Power Supply

Connections from a nominal 24VDC (500 mA or higher) power supply attach to the appropriate terminals on the electronic enclosure's terminal strip.



Isolated power is required, and this is provided by the appropriate manufacturer supplied power supply accessory. Beware of use of other power supplies which may not provide the necessary isolation and could cause instrument malfunction or damage!

5.2.5 Computer Interfacing via RS485 link

The distance between the sensor and a computer can be up to 1200 m (4000 ft.) via RS485 interface. This allows ample distance from the harsh environment where the sensing system is mounted to a control room or pulpit where the computer is located. The USB/RS485 Interface Converter allows you to connect your Endurance 1R sensor to computers by using an USB interface.

With auto configuration the converter is able to automatically configure RS485 signals without external switch setting. The converter is equipped with 3000 VDC of isolation and internal surge-protection to protect the host computer and the converter against high voltage spikes, as well as ground potential difference. When the converter is connected the computer gets one virtual COM port.

Technical Data

Power supply	5 VDC direct from USB port
Speed	max. 256 kBit/s
RS485	4 wire (full duplex) and <u>2 wire (half duplex)</u>
Terminal screwed	accepts 0.05 to 3 mm ² (AWG 13 to AWG 30)
USB connector	type B (supplied with type A to type B cable)
Ambient Temperature	0 to 60°C (32 to 140°F), 10-90% relative humidity, non-condensing
Storage Temperature	-20 to 70°C (-4 to 158°F), 10-90% relative humidity, non-condensing
Dimensions (L x W x H)	151 x 75 x 26 mm (5.9 x 2.9 x 1 in)

Just the 2-wire (half duplex) communication is supported on the Endurance 1R side. The disadvantage is that the data transfer is just alternating possible in one direction at a time. The maximum communication baud rate between the Endurance 1R device and the USB/RS485 converter is 115.200 kBaud. A Baud rate of 38.4 kBaud is the default (preset) value in the Endurance 1R device during factory setup.



The factory fix setting for the Endurance 1R is the 2-wire Mode!

Installation

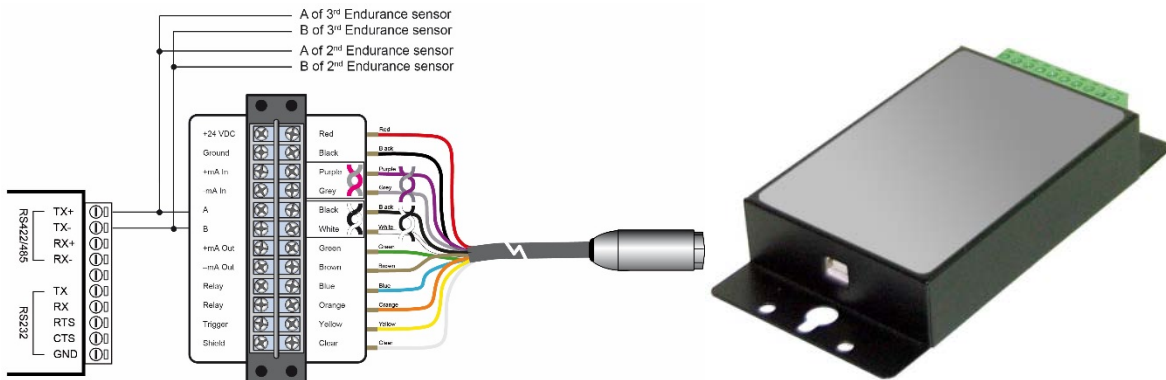

Figure 18: USB/RS485 Converter

Multiple Endurance sensors in a RS485 Multidrop Network

Wiring

For an installation of two or more Endurance sensors in a RS485 network (2-wire, half duplex), each Endurance sensor needs its specific RS485 network address (1 - 32), preset via the Endurance control panel (user interface) or alternatively via a standard terminal program (operating system dependent). Once all the units are addressed, wire up the units in the 2-wire multidrop manner, keeping all A & B signals to be common and connect these to the both signal lines of the selected USB/RS485 converter.

5.2.6 Addressing the Endurance sensor in a RS485 Multidrop Network

If you are installing two or more sensors in a multi-drop configuration, please be aware of the following:

- Each sensor must have a unique address greater zero (1 - 32).
- Each sensor must be set to the same baud rate (default is 38.4 kBaud).
- Once all the units are addressed, wire up the units in the 2-wire multidrop manner, keeping all A & B to be common.
- Now you can run own written communication software to access the Endurance sensor or use an individual terminal program to issue commands and receive the response from the sensor.

6 Operation

Once you have your sensor(s) positioned and connected properly, the system is ready for continuous operation. Operation is accomplished either through the back panel or through controlling software via the RS485 or LAN/Ethernet interface. An Endurance software, a MS-Windows based setup and configuration program is supplied with your sensor. You can also create custom programs using the communication protocols listed in section 10 Programming Guide.

6.1 Control Panel

The Endurance sensor is equipped with a control panel, which is the manually operated user interface and consists of two display types, one alarm and one status LED and several setting/controlling buttons, as shown in Figure 19. The panel is used primarily for setting up the instrument and is protectively covered over during normal use by the supplied end cap. You can configure sensor settings with the control panel or remotely with a computer.

The sensor has a remote locking feature that keeps the unit from being accidentally changed from the control panel (locked by default in multidrop mode). This lockout mode denies access to the submenu functions of the control panel. Via the RS485, the LAN/Ethernet connection or a specific key command on the control panel, the Endurance device can be unlocked.

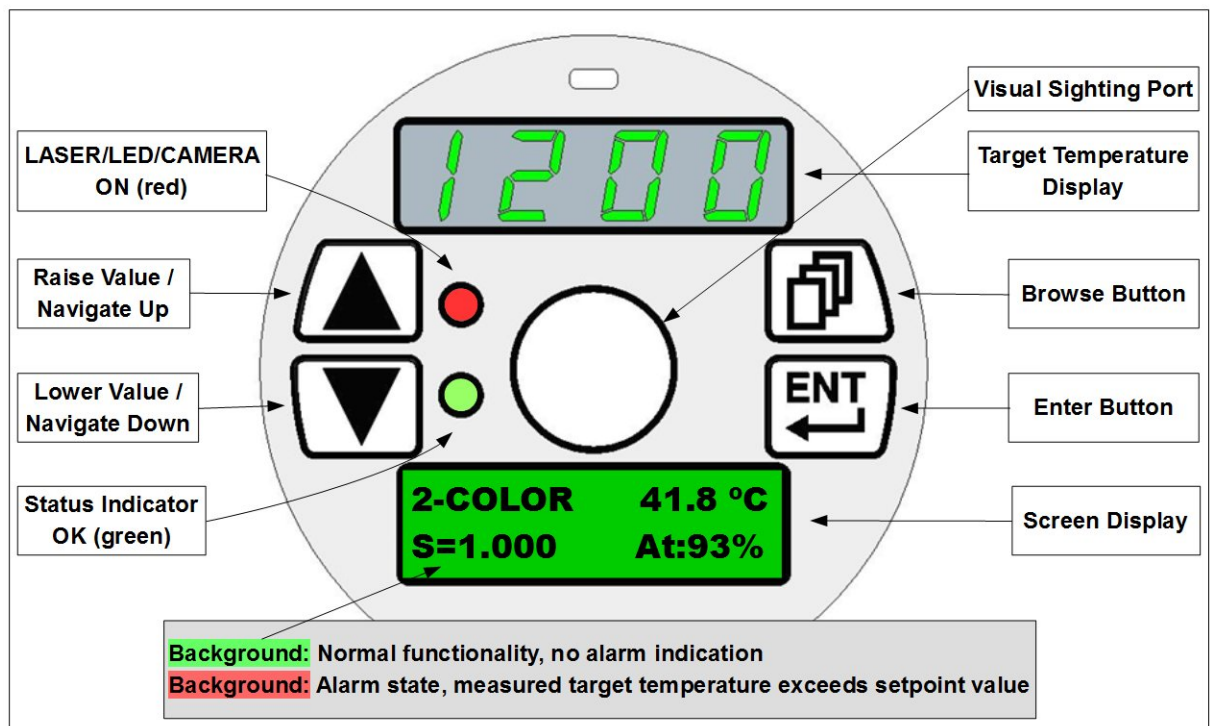
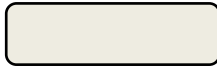

Figure 19: Control Panel

Operation

6.1.1 The Temperature Display (green 7-segment LED type)



The temperature display always shows the current value of the measured target temperature, including the result of any signal processing (such as Averaging, Peak Hold, Valley Hold). Units of measure are set in the screen display – Configuration mode – described later in this section.

The Temperature Display has to fulfill two tasks to inform the operator:

- In normal operation after warm up phase, it displays the current measured object temperature, including any signal processing like “Averaging Hold”, “Peak Hold” or “Valley Hold”. The displayed temperature depends on the preset measurement unit (°C or °F), done in the “CONFIGURATION MENU” and described hereafter.
- In abnormal operation, during warm up phase or in failure case, discovered through the failsafe-circuit, it displays an error code (e.g. ECHH, ECUU, EUUU, EAAA...). Please see section 11.2 **Fail-Safe Operation** on page 55.

6.1.2 The Screen / Menu Display

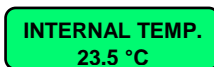

The Screen/Menu Display is the central user interface display, which shows all selected menus, their submenus and parameters. In dependence of the selected main menu item, it displays the first submenu item as default. The menu, submenu and entry selection will be done by specific buttons, described herein afterwards.

6.1.3 The Pointing Device Indicator LED (red)



Indicates the switched-on state of the integrated pointing device LASER, LED or CAMERA.

6.1.4 The Status Indicator LED (green)



Shows a steady green after warm up period to indicate an error free function of the Endurance device.

6.1.5 The four control elements (pushbuttons) of the control panel

6.1.5.1 The Browser Button

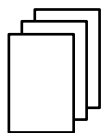

The Browser Button serves as a selector for one of the 5 integrated submenus. The specific submenu selection can be done in the following ways:

- Pressing the Browser Button several times in series to toggle between the 5 submenus
- Holding the Browser Button pressed, toggles between the 5 submenus about every 2 sec

Stop to press the Browser Button, if you've reached the preferred submenu, displayed on the Screen/Menu display. The first menu entry of the selected submenu will be displayed as default.

The available submenus are:

- INFORMATION MENU
- CONFIGURATION MENU
- UNIT SETUP MENU
- INTERFACE MENU
- ANALOG MENU

6.1.5.2 The ENTER Button



The Enter Button confirms the selection of a submenu or a specific submenu entry. After walking through the listed submenu entries by using the Navigate Buttons, the selection done by the Enter Button initiates a blinking of the modifiable entry, displayed in the 2nd row of the Screen/Menu display. To store updated entries a final press of the Enter Button is needed. With the Enter Button you also walk through multiple section entries, like network IP-addresses (4 subfields with a value range of 0-255).

6.1.5.3 The Navigate Up Button



The Navigate Up Button enables you to walk through the list of integrated entries per submenu, increases marked numerical values or toggles the specific entry.

6.1.5.4 The Navigate Down Button



The Navigate Down Button enables you to walk through the list of integrated entries per submenu, decreases marked numerical values or toggles the specific entry.

Operation

6.2 The selectable submenus and associated entries

6.2.1 The INFORMATION MENU

The INFORMATION MENU is just for information and displays several unchangeable status data.









The order in which the status data appears is the following:

- CONDENSED INFOS (content is color mode and signal processing dependent; MODE, INTERNAL TEMP. and EMISSIVITY is fix for 1-COLOR
 - 1-COLOR, AVERAGE e.g. 1-COLOR__44.2°C, E=1.00__Av:10.0s
 - 1-COLOR, PEAK HOLD e.g. 1-COLOR__44.2°C, E=1.00__Ph:10.0s
 - 1-COLOR, VALLEY HOLD e.g. 1-COLOR__44.2°C, E=1.00__Vh:10.0s
- 2-COLOR e.g. 2-COLOR__44.2°C, S=1.000__At:95%)
- INTERNAL TEMP. in °C or °F (e.g. 39.8 °C)
- ATTENUATION in % (e.g. 100%)
- LOW LIMIT in °C (e.g. 400.0 °C)
- HIGH LIMIT in °C (e.g. 3000.0 °C)
- SENSOR IDENT (e.g. E1RL-F2-D-0-0)
- SENSOR REVISION (e.g. 1.01.28)
- SERIAL NUMBER (e.g. 31760001)
- MAC ADDRESS (e.g. 001d8d200001)

6.2.2 The CONFIGURATION MENU

The CONFIGURATION MENU displays and accepts modifications of configuration data.











The order in which the configuration data appears is the following:

- MODE ( toggles between 1 – color and 2 - color)
- TEMP. UNITS ( toggles between °C and °F)
- RELAY MODE ( toggles between NORMALLY OPEN, PERMANENTLY CLOSE, PERMANENTLY OPEN, NORMALLY CLOSE)
- ATTENUATION RELAY ( toggles between 0% to 95%)
- ATTENUATION FAILSAFE ( toggles between 0% to 95%)
- POINTING DEVICE (content is dependent of integrated pointing device hardware
 - NO DEVICE FOUND e.g. LASER/LED/CAMERA, NOT PRESENT
 - LASER  toggles between OFF and ON
 - LED  toggles between OFF and ON
 - CAMERA  toggles between OFF and ON)
- FACTORY DEFAULT ( toggles between NO and YES)
- KEY ENTER (UNLOCKED)

6.2.3 The UNIT SETUP MENU

The UNIT SETUP MENU displays and accepts modifications of unit setup data.









The order in which the unit setup data appears is the following:

- SLOPE ( toggles between 0.850 to 1.150)
- EMISSIVITY ( toggles between 0.10 to 1.10)
- TRANSMISSIVITY ( toggles between 0.10 to 1.10)
- MATCH ( adapts displayed target temperature to real target temperature by adaption of Emissivity [1C-mode] or Slope [2C-mode])
- AVERAGE (  toggles between 0.0 sec. to 300.0 sec.)
- PEAK HOLD ( toggles between 0.0 sec. to 300.0 sec.)
- VALLEY HOLD ( toggles between 0.0 sec. to 300.0 sec.)
- SETPOINT ( toggles between 0.0 °C to >3000.0 °C)
- DEADBAND ( toggles between 1 °C to 55 °C)

6.2.4 The INTERFACE MENU

The INTERFACE MENU displays and accepts settings of both integrated communication interfaces (RS485 & LAN/Ethernet).



The order in which the interface setup data appears is the following:

- RS485 BAUD RATE ( toggles between 1200, 2400, 9600, 19200, 38400, 57600, 115200 bps)
- MULTIDROP ADDR. ( toggles between 000 to 032)
- TERMIN. RESISTOR ( toggles between OFF and ON)
- ETHERNET DHCP ( toggles between OFF and ON)
- ETHERNET IP (ENTER Button selects IP address byte aaa.bbb.ccc.ddd  toggles between 0 and 255)
- ETHERNET NM (ENTER Button selects network mask byte aaa.bbb.ccc.ddd  toggles between 0 and 255)
- ETHERNET GW (ENTER Button selects gateway addr. byte aaa.bbb.ccc.ddd  toggles between 0 and 255)
- ETHERNET PORT ( toggles between TCP/UDP port 0 to 65535)
- WEB SERVER ( toggles between OFF and ON)

6.2.5 The ANALOG MENU

The ANALOG MENU displays and accepts settings of the integrated current loop analog output interface (0 – 20mA, 4 – 20mA).

The order in which the analog setup data appears is the following:

- ANALOG OUT MODE ( toggles between 0 – 20mA, 4 – 20mA)
- OUT Lo LIMIT ( toggles between 0 °C to > 3000 °C)
- OUT Hi LIMIT ( toggles between 0 °C to > 3000 °C)

Operation

6.3 Total Control Panel (User Interface) Structure

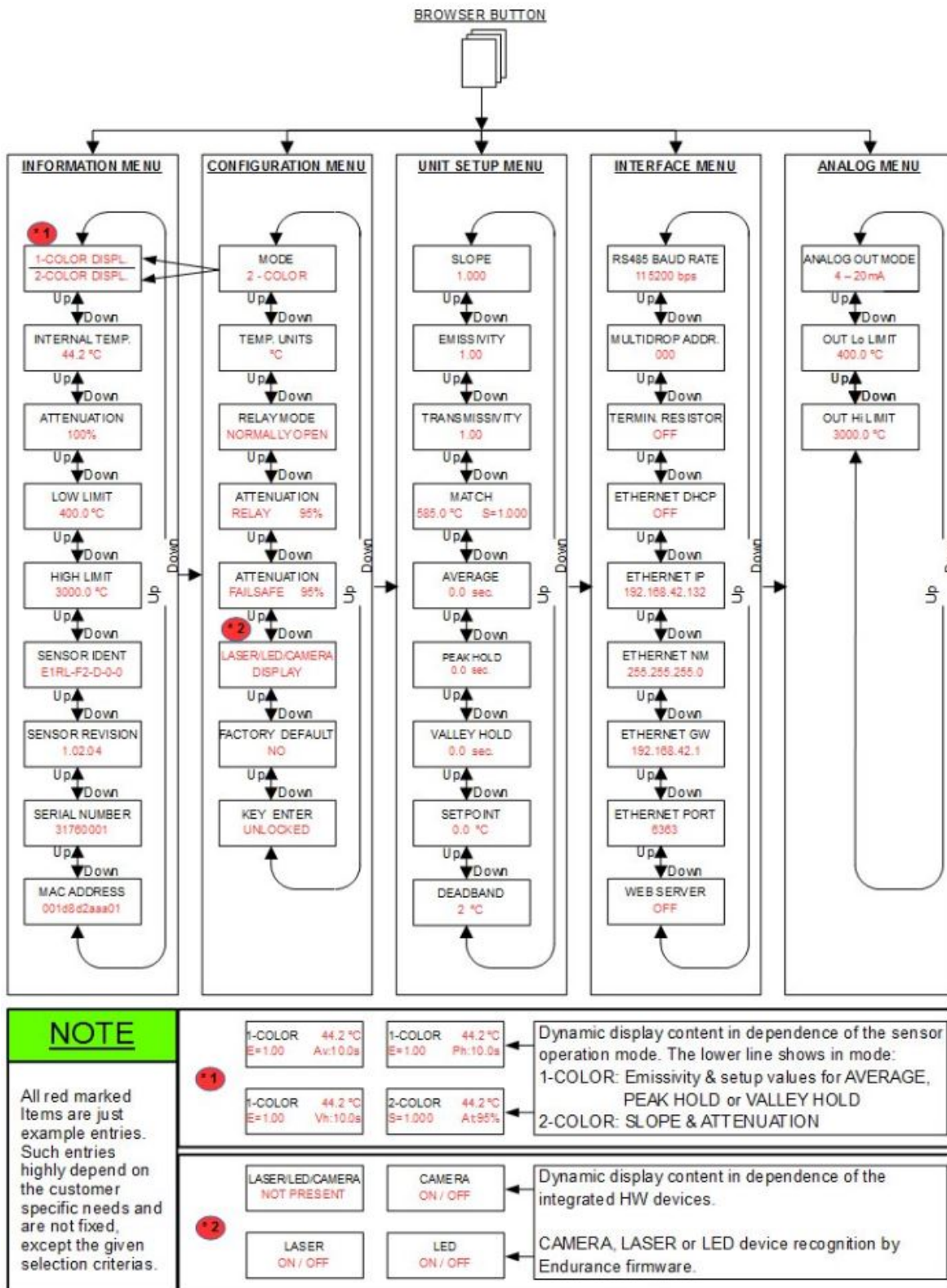

Figure 20: User Interface Flow Diagram

7 Signal Post Processing Details

7.1 Averaging

Averaging is used to smooth the output signal. The signal is smoothed depending on the defined time basis. The output signal tracks the detector signal with significant time delay in which noise and short peaks are damped. A longer average time smoothens the damping behavior. The average time is the amount of time the output signal needs to reach 90% magnitude of an object temperature jump. The range for the average time can be set from 0.1 to 300.0 seconds, whereas just 0.1 - 299.9 seconds will be interpreted as averaging duration. A value of 300.0 seconds indicates that averaging post processing depends on an external trigger signal. A low level input (GND) at external input (Trigger) will promptly interrupt the averaging and will restart the average calculation with the current temperature reading.

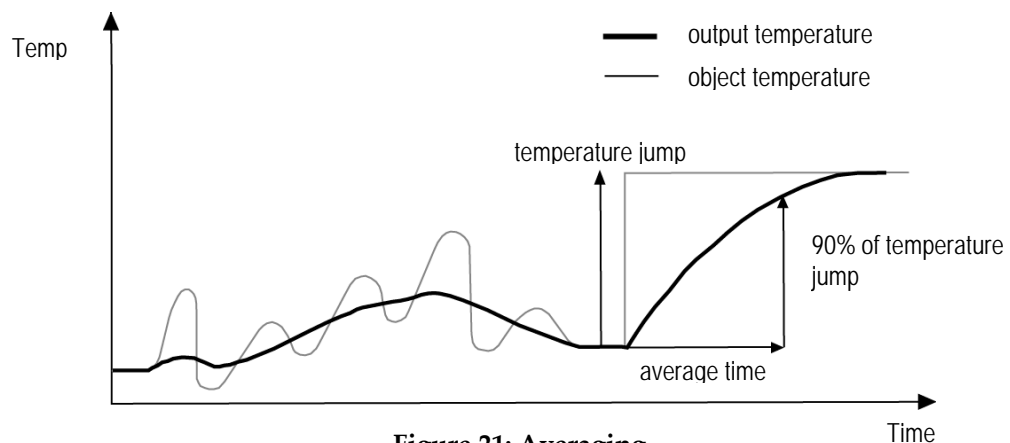

Figure 21: Averaging

Attention: The disadvantage of averaging is the time delay of the output signal. If the temperature jumps at the input (hot object), the output signal reaches only 90% magnitude of the actual object temperature after the defined average time.

Once Averaging is set above 0, it automatically activates. Note that other hold functions (like Peak Hold or Valley Hold) cannot be used concurrently.

7.2 Peak Hold

The output signal follows the object temperature until a maximum is reached. The output will „hold“ the maximum temperature value for the selected duration of the peak hold time. Once the hold time is expired, the peak hold function will reset and the output will resume tracking the object temperature until a new peak is reached. The range for the peak hold time can be set from 0.1 to 300.0 seconds, whereas just 0.1 - 299.9 seconds will be interpreted as peak hold duration. A value of 300.0 seconds indicates that peak hold post processing depends on an external trigger signal. A low level input (GND) at external input (Trigger) will promptly interrupt the peak hold function and restarts the peak holding with the current temperature reading.

Signal Post Processing Details

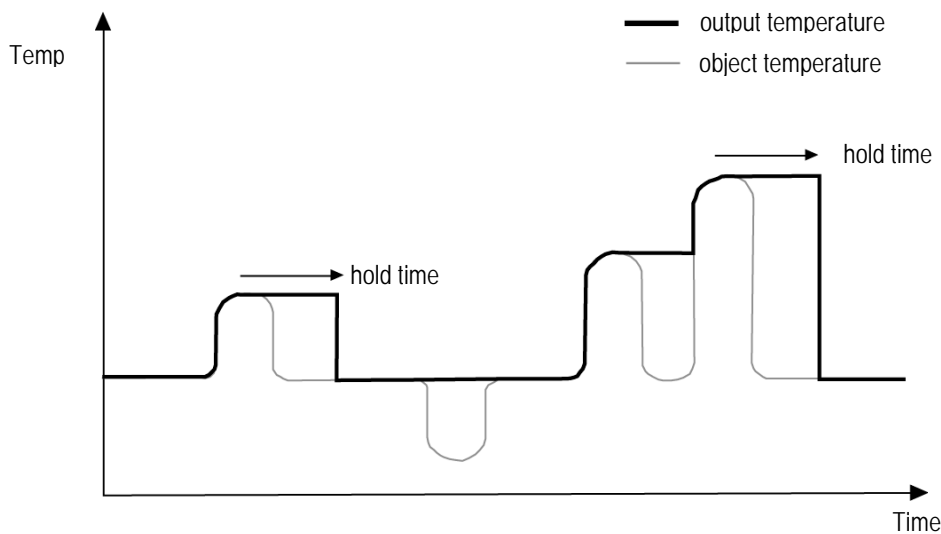

Figure 22: Peak Hold

Once Peak Hold is set above 0, it automatically activates. The output signal remains the same until one of two things happens:

- The peak hold time runs out. In this case, the signal reverts to actual temperature.
- The actual temperature goes above the hold temperature. In this case, starts holding new peak.

Note that other signal processing functions (like Averaging or Valley Hold) cannot be used concurrently with Peak Hold.

7.3 Valley Hold

The output signal follows the object temperature until a minimum is reached. The output will „hold“ the minimum temperature value for the selected duration of the valley hold time. Once the hold time is expired, the valley hold function will reset and the output will resume tracking the object temperature until a new valley is reached. The range for the valley hold time can be set from 0.1 to 300.0 seconds, whereas just 0.1 - 299.9 seconds will be interpreted as valley hold duration. A value of 300.0 seconds indicates that valley hold post processing depends on an external trigger signal. A low level input (GND) at external input (Trigger) will promptly interrupt the valley hold function and restarts the valley holding with the current temperature reading.

Signal Post Processing Details

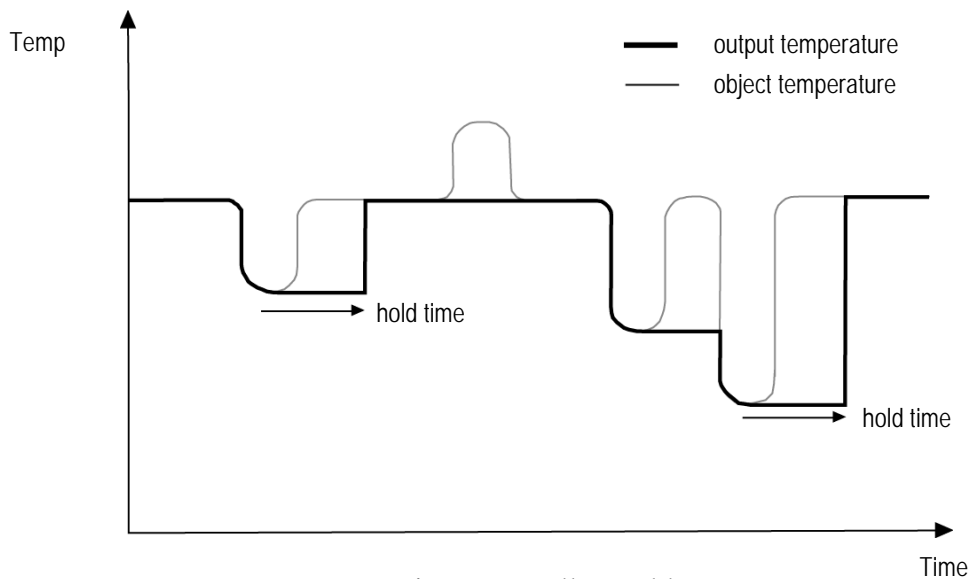

Figure 23: Valley Hold

Once Valley Hold is set above 0, it automatically activates. The output signal remains the same until one of two things happens:

- The valley hold time runs out. In this case, the signal reverts to actual temperature.
- The actual temperature goes below the hold temperature. In this case, starts holding new valley.

Note that other signal processing functions (like Averaging or Peak Hold) cannot be used concurrently with Valley Hold.

7.4 Setpoint

The Setpoint function is a temperature supervising alarm mechanism, which can be activated. A Setpoint entry defines a maximum supervising value for the target temperature. If the Setpoint value is exceeded, an alarm state will be signaled by a relays contact. A zero (0.0) entry as a Setpoint value deactivates the alarm functionality (Alarm mode off). To activate the alarm functionality, set the Setpoint entry to a value between the lowest and the highest measurable target temperature. Once the Setpoint is activated the relay changes state as the current temperature passes the setpoint temperature.

7.5 Deadband

Deadband is a zone of flexibility around the Setpoint. The alarm does not go abnormal until the temperature exceeds the Setpoint value by the number of set deadband degrees. Thereafter, it does not go normal until the temperature is below the Setpoint by the number of set deadband degrees. The Deadband is factory preset to $\pm 2^\circ$ (C or F). Adjusting the Deadband entry is accomplished through software or manual input via the control panel. For information regarding the Endurance sensor communication protocols, see section 10 Programming Guide page 49. The following figure is an example of the Deadband around a Setpoint temperature of 960°C (1760°F).

Signal Post Processing Details

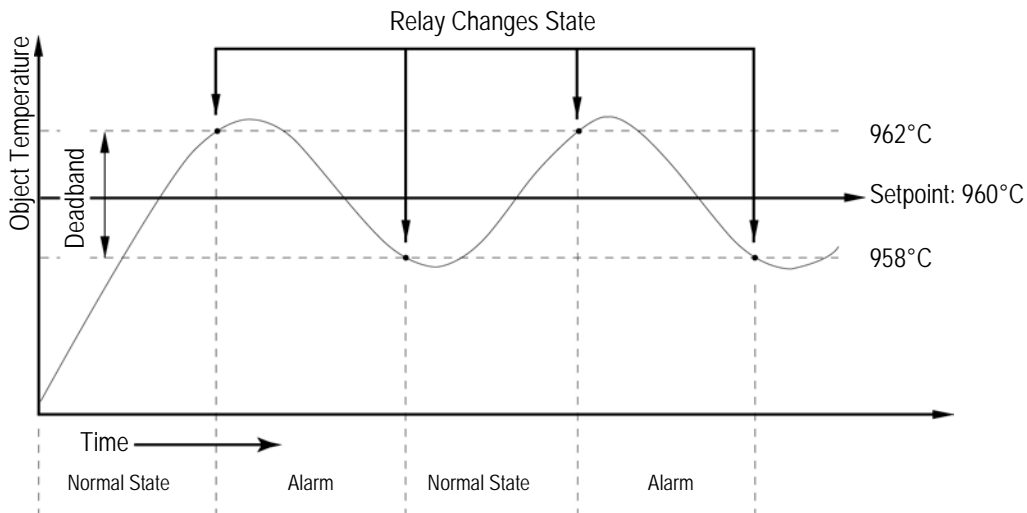

Figure 24: Deadband Example

7.6 Outputs

7.6.1 Analog Output (current loop)

A current loop output circuit, which can be set either to 0-20mA or 4-20mA output current range, drives the analog output signal. It can be connected directly to a recording device (e.g., chart recorder), PLC, or controller. The whole analog output circuit impedance is limited to 500Ω. The current loop resolution through a 16Bit DAC (Digital Analog Converter) per temperature unit is better than 0.1 (°C or °F) over the total measurement range. A specific feature for the testing or calibrating of connected equipment allows the current loop output to be set to specific values, under range or over range in RS485 or LAN/Ethernet operation mode. Via such functionality you can force the circuit, operating in the 4-20mA mode, to transmit an output current less than 4mA (e.g. 2.0 or 3.0mA) or above 20mA (e.g. 21.0 or 22.0mA).

7.6.2 Relay Outputs

The relay output is used as an alarm for failsafe conditions or as a setpoint relay. Please refer to section 11.2 Fail-Safe Operation on page 55. Relay output relate to the current target temperature, displayed on the green 7-segment LED display. The relay output can be used to indicate an alarm state or to control external actions. The relay functionality can either be set to

NO (NORMALLY OPEN), NC (NORMALLY CLOSE),
PO (PERMANENTLY OPEN), PC (PERMANENTLY CLOSE)

by the control panel (user interface), an RS485 or LAN/Ethernet command in dependence of the connected equipment. The relay PO and PC state can be used to detect wiring problems between the Endurance sensor and the process environment, where the relay contact signal acts as a trigger.

7.6.3 Trigger

AVERAGE, PEAK HOLD or VALLEY HOLD can be reset by shorting the Trigger input signal to Ground for a minimum of 10 msec. This can be done either with a momentary switch or a relay. The Reset signal causes a new reading of the current measured temperature and restarts the selected signal post processing function.

Signal Post Processing Details

7.7 Factory Defaults

To globally reset the unit to its factory default settings, go to the “factory default” menu item under the configuration screen menu display. The baud rate and communications mode (single device or multiple devices / multidrop) will not be affected.

Parameter	As shipped from Factory (Defaults)
Mode (1C / 2C)	2C- mode
Temperature Unit (°C / °F)	C
Slope	1.000
Emissivity	1.00
Transmissivity	1.00
Average	0.0
Peak Hold	0.0
Valley Hold	0.0
SETPOINT in (°C / °F)	0.0
DEADBAND in (°C / °F)	2
RS485 Communication Mode	2-wire half duplex, 38.400 Baud *
MULTIDROP ADDRESS	000 (single Endurance sensor)
TERMINAL RESISTOR	OFF
ETHERNET DHCP	OFF
ETHERNET IP-ADDRESS	192.168.42.132
ETHERNET NETMASK	255.255.255.0
ETHERNET GATEWAY ADDR.	192.168.42.1
ETHERNET PORTNUMBER	6363
WEB SERVER	OFF
ANALOG OUTPUT MODE	4 – 20mA
OUT Lo LIMIT for 4 mA	Low end of sensor temperature range (e.g. 400.0°C)
OUT Hi LIMIT for 20 mA	High end of sensor temperature range (e.g.3000.0°C)
Serial Output Transmission Mode	Burst mode, Default string = UTSI
Relay Output Control	Controlled by unit, NO function (indicates failsafe alarms)
Set Output Current	Controlled by unit, 4-20 mA
Lockout Control Panel Access	Unlocked

* RS485 Modes, like Baud Rate or 2-wire half duplex, are unchanged when the factory defaults are restored

Table 2: Factory Defaults

Options

8 Options

Options are items that are factory installed and must be specified at time of order. The following are available:

- Laser Sighting
- LED Sighting
- Video Sighting
- ISO Calibration Certificate, based on DAkkS (Deutsche Akkreditierungsstelle)
- Air/Water-Cooled Housing

8.1 Laser Sighting

The laser sighting allows fast and precise aiming at small, rapidly moving targets, or targets passing at irregular intervals. The laser is specially aligned with the sensor's lens to provide accurate, non-parallax pinpointing of targets. The laser comes as a small, bright red spot indicating the center of the area being measured.

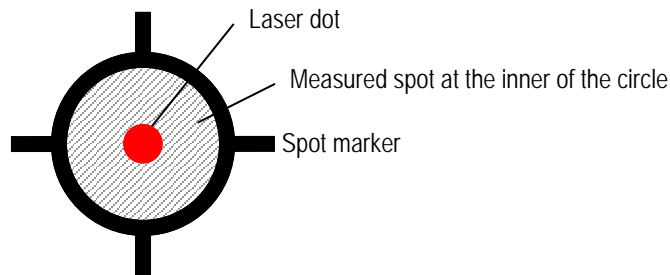

Figure 25: LASER Spot Size Indication

The laser is a Class II, AlGaInP type laser with an output power less than 1 mW, and an output wavelength of 650 nm. The laser complies with FDA Radiation Performance Standards, 21CFR, subchapter J, and meets IEC 825, Class 2 specifications.



To preserve laser longevity, the laser automatically turns off after approximately 10 minutes of constant use!

WARNING!

Avoid exposure to LASER light! Eye damage can result.
Use extreme caution when operating!
Never look direct into the LASER beam.
If LASER Sighting is activated, avoid looking through the Visual Sighting Port of the Control Panel, because mirror and dispersion effects can injure Eyes.
Never point directly at another person!



8.2 LED Sighting

The LED sighting allows fast and easy aiming at targets, which have to be centered in the measurement spot. The LED is specially aligned with the sensor's lens to provide accurate, non-parallax pinpointing of targets. The LED comes as a small, bright green spot, which indicates the whole dimension of the measurement area.

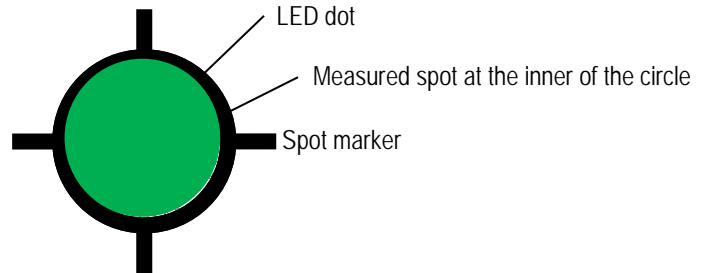

Figure 26: LED Spot Size Indication



To preserve LED longevity, the LED automatically turns off after approximately 10 minutes of constant use!

WARNING!

Avoid exposure to LED light! Eye damage can result.

Use extreme caution when operating! Never look direct into the LED beam.

If LED Sighting is activated, avoid looking through the Visual Sighting Port of the Control Panel, because mirror and dispersion effects can injure Eyes.



8.3 Video Sighting

The Video Sighting capability is an option to display the focused target area on an external computer monitor via LAN/Ethernet link. The video resolution and the refresh rate depends on the system architecture (single or multidrop) and the available network bandwidth. It can be used for picture capturing in different applications.

8.4 Air/Water Cooled Housing

The Air/Water Cooled Housing allows the sensor to be used in ambient temperatures up to 120°C (250°F) with air cooling, and 175°C (350°F) with water cooling. The cooling media should be connected using 1/8" NPT stainless steel fittings requiring 6 mm (0.24 in) inner diameter and 8 mm (0.31 in) outer diameter for the tube.

Options

Air flow should be 1.4 to 2.5 l/sec at 25°C (77°F). Water flow should be approximately 1.0 to 2.0 l/min (water temperature between 10 and 27°C / 50 to 80.6°F). The maximal pressure limit is 5 bar (73 PSI). Chilled water below 10°C (50°F) is not recommended.



The Air/Water Cooled Housing is delivered with plugs only removable with a 5 mm hex wrench. Check your supplier for appropriate fittings.

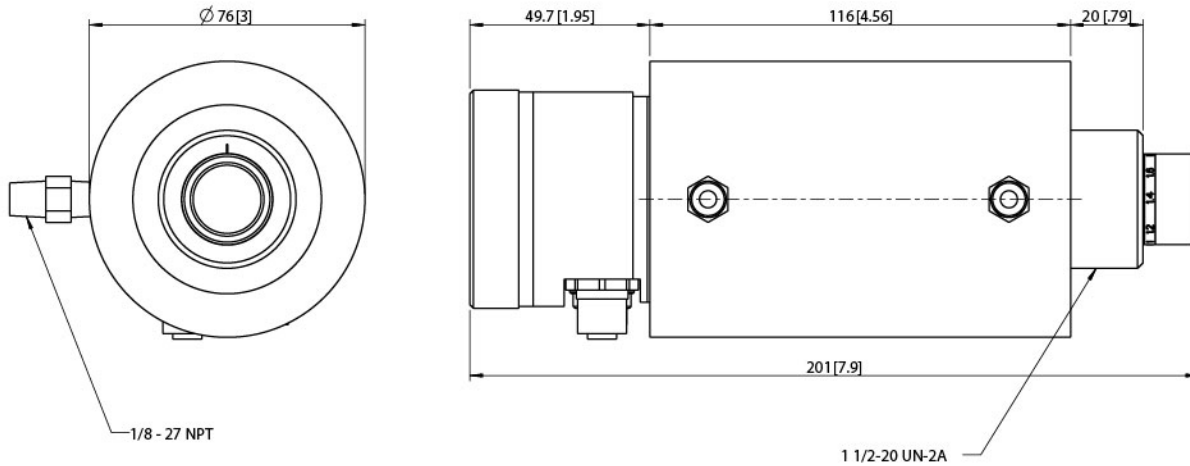

Figure 27: Endurance Head with Air/Water-Cooled Housing Option



For ambient temperatures exceeding 175°C (350°F), the ThermoJacket can be used. This accessory allows operation at ambient temperatures up to 315°C (600°F)!

8.4.1 Avoidance of Condensation

If environmental conditions makes water cooling necessary, it is strictly recommended to check whether condensation will be a real problem or not. Water cooling also causes a cooling of the air in the inner part of the sensor, thereby decreasing the capability of the air to hold water. The relative humidity increases and can reach 100% very quickly. In case of a further cooling, the surplus water vapor will condense out as water. The water will condense on the lenses and the electronics resulting in possible damage to the sensor. Condensation can even happen on an IP65 sealed housing.



There is no warranty repair possible in case of condensation within the housing!

To avoid condensation, the temperature of the cooling media and the flow rate must be selected to ensure a **minimum** device temperature. The minimum sensor temperature depends on the ambient temperature and the relative humidity. Please consider the following table.

		Relative Humidity [%]																		
		10	15	20	25	30	35	40	45	50	55	60	65	70	75	80	85	90	95	100
Ambient Temperature [°C/°F]	0/ 32	0/32	0/32	0/32	0/32	0/32	0/32	0/32	0/32	0/32	0/32	0/32	0/32	0/32	0/32	0/32	0/32	0/32	0/32	0/32
	5/ 41	0/32	0/32	0/32	0/32	0/32	0/32	0/32	0/32	0/32	0/32	0/32	0/32	0/32	0/32	0/32	0/32	0/32	0/32	5/41
	10/ 50	0/32	0/32	0/32	0/32	0/32	0/32	0/32	0/32	0/32	0/32	0/32	0/32	0/32	5/41	5/41	5/41	5/41	5/41	10/50
	15/ 59	0/32	0/32	0/32	0/32	0/32	0/32	0/32	0/32	0/32	5/41	5/41	5/41	5/41	10/50	10/50	10/50	10/50	10/50	15/59
	20/ 68	0/32	0/32	0/32	0/32	0/32	0/32	5/41	5/41	5/41	10/50	10/50	10/50	10/50	15/59	15/59	15/59	15/59	15/59	20/68
	25/ 77	0/32	0/32	0/32	0/32	5/41	5/41	10/50	10/50	10/50	10/50	15/59	15/59	15/59	20/68	20/68	20/68	20/68	20/68	25/77
	30/ 86	0/32	0/32	0/32	5/41	5/41	10/50	10/50	15/59	15/59	15/59	20/68	20/68	20/68	20/68	25/77	25/77	25/77	25/77	30/86
	35/ 95	0/32	0/32	5/41	10/50	10/50	15/59	15/59	20/68	20/68	20/68	25/77	25/77	25/77	25/77	30/86	30/86	30/86	30/86	35/95
	40/ 104	0/32	5/41	10/50	10/50	15/59	20/68	20/68	20/68	25/77	25/77	25/77	30/86	30/86	30/86	35/95	35/95	35/95	35/95	40/104
	45/ 113	0/32	10/50	15/59	15/59	20/68	25/77	25/77	25/77	30/86	30/86	35/95	35/95	35/95	35/95	40/104	40/104	40/104	40/104	45/113
	50/ 122	5/41	10/50	15/59	20/68	25/77	25/77	30/86	30/86	35/95	35/95	35/95	40/104	40/104	40/104	45/113	45/113	45/113	45/113	50/122
	60/ 140	15/59	20/68	25/77	30/86	30/86	35/95	40/104	40/104	40/104	45/113	45/113	50/122	50/122	50/122	50/122	50/122	50/122	50/122	60/140
	70/ 158	20/68	25/77	35/95	35/95	40/104	45/113	45/113	50/122	50/122	50/122	50/122	50/122	50/122	60/140	60/140				
	80/ 176	25/77	35/95	40/104	45/113	50/122	50/122	60/140	60/140	60/140	60/140	60/140	60/140							
	90/ 194	35/95	40/104	50/122	50/122	60/140	60/140													
	100/ 212	40/104	50/122	50/122	60/140	60/140														

Tab. 3: Minimum device temperatures [°C/°F]

Example:

Ambient temperature = 50 °C
 Relative humidity = 40 %
 Minimum device temperature = 30 °C

The use of lower temperatures is at your own risk!

Temperatures higher than 65°C (149°F) are not recommended due to the temperature limitation of the sensor.

Accessories

9 Accessories

9.1 Overview

A full range of accessories for various applications and industrial environments are available. Accessories include items that may be ordered at any time and added on-site. These include but are not limited to the following:

E-PS	Power Supply (24VDC, 110/220VAC input) & Endurance Terminal Block mounted in a NEMA 4 (IP65) enclosure
E-POE	PoE Injector provides power and also acts as a single Ethernet hub (110/220VAC input) includes 2M office grade Ethernet cable
E-SYSPS	24 VDC 1.2 A industrial power supply, DIN rail mount
E-TB	Endurance terminal block accessory
E-TBN4	Endurance terminal block in a NEMA 4 enclosure
E-AP	Air purge collar
E-PA	Pipe adapter (Sighting tubes listed below can be attached to this)
E-MN	Mounting nut (spare)
E-FB	Fixed bracket (spare)
E-AB	Adjustable bracket
E-SB	Swivel bracket
E-RA	Right angle mirror (for targets at right angles to sensor axis)
E-2CCON	12-pin DIN Cable connector
E-M5PK	M5 patch cable kit (To allow Endurance use with existing M5 cables)
E-M5WJAK	Modline 5 WJA adapter kit to allow for use of ER sensors in WJA
E-UAA	Endurance UAA (Universal Adapter Accessory)
E-AK-7	Adapter kit for mounting Endurance into existing WJ-5 water jacket installations
E-MF-7	Mounting flange
E-MFA-7	Flange adapter (to allow Endurance to mount to MF-7)
E-ECAP	Replacement glass end-cap for Endurance sensors
E- PW	Protective front window (includes O-Ring)
E-PFEC	Polarizing filter end cap (EN1R for reducing visual light in high temperature applications)
E-TJ1	ThermoJacket housing for Endurance sensors
E-TJ1M	ThermoJacket housing for Endurance sensors Metric Version
E-MF	Mounting Flange for ThermoJacket
E-MB	Adjustable mounting base for ThermoJacket
E-GTQ	Blast Gate Assembly with Quartz Window (HT model)
E-APA	Adjustable pipe adapter assembly
E-MST	Mounting flange for use with sighting tubes
E-STC12	30 cm (12") sighting tube, ceramic up to 1500°C (2730°F)
E-ST12	30 cm (12") sighting tube, stainless steel up to 800°C (1470°F)
E-BEESIGHT	30 cm (12") sighting tube, carbon steel with 45 degree end cut and slotted weep hole at base
E-2CFT	Focus adjustment tool, for use when Endurance sensors are installed in a ThermoJacket.
E-WR	Water flow regulator (water cooling)
E-AR	Air purging flow regulator assembly with air filter
E-CAFR	Cooling air flow regulator (high capacity)
E-USB485	USB to RS232/422/485 converter

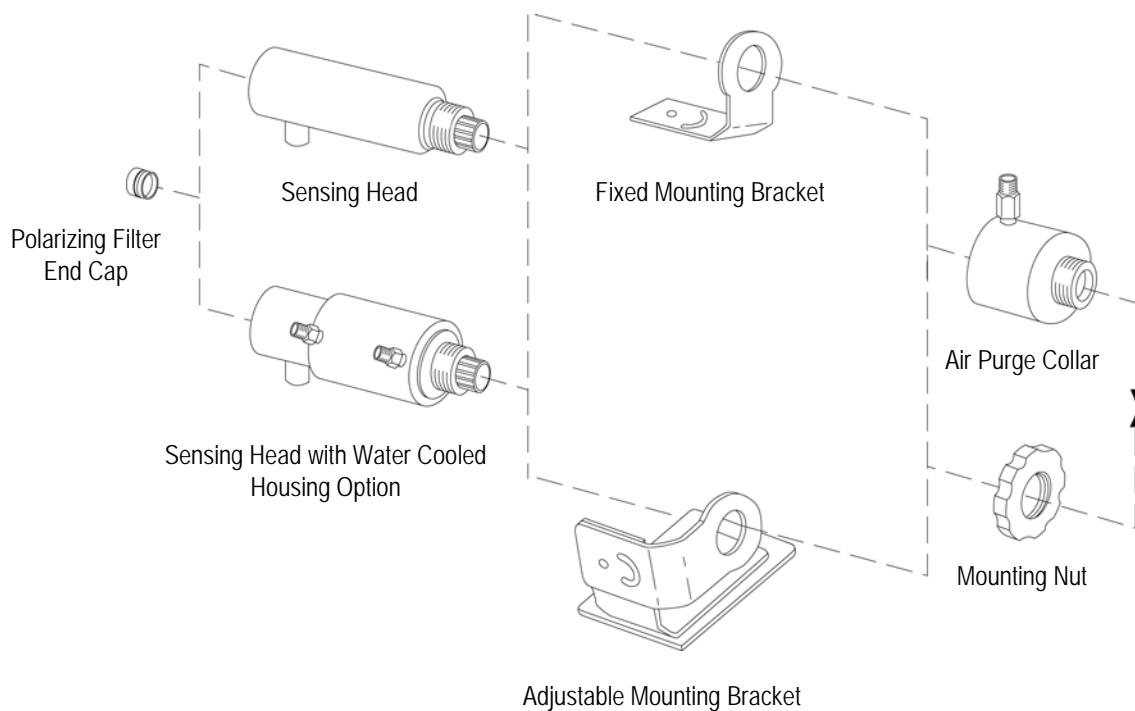

Figure 28: Sensing Head with Air/Water-Cooled Housing Option

9.2 Fixed Mounting Bracket

The Fixed Mounting Bracket accessory can be used if the sensor will always remain in a fixed location.

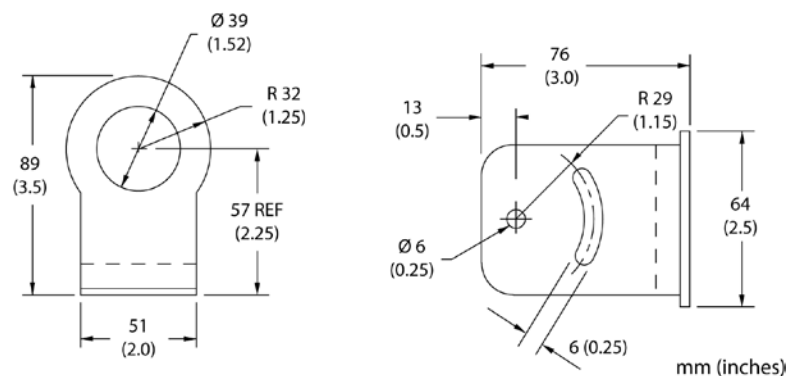

Figure 29: Fixed Mounting Bracket

9.3 Air Purge Collar

The Air Purge Collar accessory is used to keep dust, moisture, airborne particles, and vapors away from the lens. It can be installed before or after the bracket. It must be screwed in fully. Air flows into the 1/8" NPT fitting and out the front aperture. Air flow should be a maximum of (0.5 to 1.5 liters/sec

Accessories

or 0.13 to 0.4 gallon/sec). Clean (filtered) or “instrument” air is recommended to avoid contaminants from settling on the lens. Do not use chilled air below 10°C (50°F).



Focus the instrument before attaching the air purge collar.

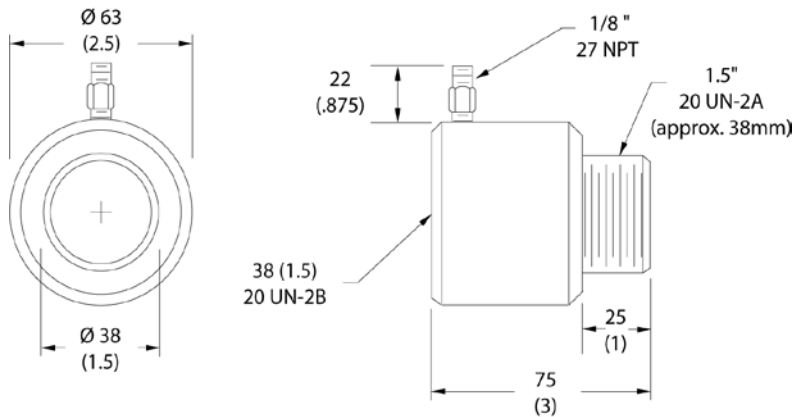

Figure 30: Air Purge Collar

9.4 Polarizing Filter End Cap

A specific Polarizing Filter End Cap with an integrated Polarizing Filter can be ordered. The Polarizing Filter will not fit in the standard Endurance end cap. The filter is foreseen for eye protection when sighting on bright, high temperature targets through the visual sighting port. The filter does not affect measured energy. It is solely for viewing comfort. Rotate the outer portion of the filter until you achieve the desired visual attenuation.

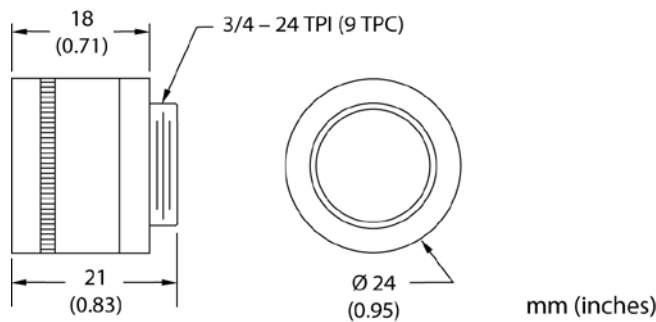

Figure 31 Polarizing Filter



Polarizing filter will not fit in the standard end cap. Do not look through the lens at extremely bright objects with your eyes unprotected. Eye damage could occur.

9.5 Cables

Two cable types are available for the Endurance sensor head. A shielded 12 conductor cable, made of 2 twisted pairs plus 8 separate wires, equipped with a M16 DIN connector on one side and wire sleeves at the counter side. This cable houses RS485 communication signals, 24VDC power lines and analog output signals. The second cable is a 4 conductor LAN/Ethernet cable, equipped with a M12 DIN connector on one side and a standard RJ45 connector on the counter side. Via the 4 connector cable, the Endurance device can also be powered by PoE, if a specific PoE injector will be used. Both cable types are available for low and high ambient temperature ranges and different cable lengths.



If you purchase your own shielded 12 conductor cable, use wire and shielding regarding the valid Fluke Process Instruments specification. Maximum RS485 cable length is 1200 meters (4000 feet). Power supply (24VDC) feed in distance to the sensor head should not extend the 60m limit.



If you cut the shielded 12 connector cable to shorten it, notice that both sets of twisted-pair wires have drain wires inside their insulation. These drain wires (and the white wire that is not part of the twisted pair) must be connected to the terminal labeled CLEAR. Refer to Section 5.2.3.3 for terminal block wiring diagram.

Accessories

9.6 Industrial Power Supply

The DIN-rail mount industrial power supply delivers isolated dc power and provides short circuit and overload protection.



To prevent electrical shocks, the power supply must be used in protected environments (such as inside electrical cabinets)!

Technical data:

Protection class	class II as per IEC/EN 61140
Environmental protection	IP20
Operating temperature range	-25°C to 70°C (-13°F to 158°F)
AC Input	100 – 240 VAC 50/60 Hz [L/N]
wire size	0.5 to 2 mm ² (AWG 24 to 12)
DC Output	24 VDC / 1.25 A [+/-]
wire size	0.5 to 2 mm ² (AWG 24 to 12)

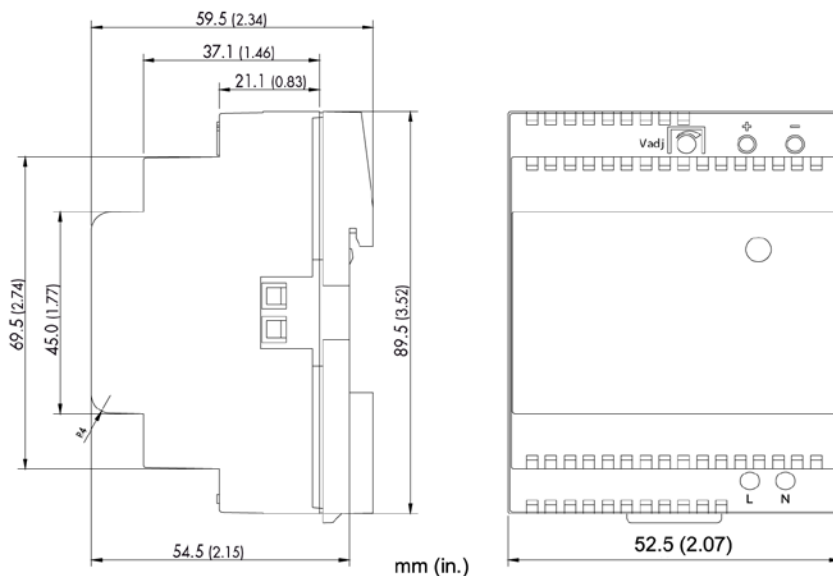

Figure 32: Dimension of Industrial Power Supply

10 Programming Guide

This section explains the sensor's communication protocol to be used when writing custom programs for your applications or when communicating with your sensor with a terminal program over RS485 or LAN/Ethernet interface.

10.1 Remote versus Manual Considerations

Since the sensor includes a local user interface, the possibility exists for a person to make manual changes to parameter settings. To resolve conflicts between inputs to the sensor, the following rules are valid:

- Command precedence: the most recent parameter change is valid, whether originating from manual or remote.
- If a manual parameter change is made, the sensor will transmit a "notification" string to the host. (Notification strings are suppressed in multidrop mode.)
- A manual lockout command is available in the protocols set so the host can render the user interface "display only," if desired.

All parameters set via the Control Panel (user interface), the RS485 (2-wire, half duplex) or the LAN/Ethernet interface are retained in the sensor's nonvolatile memory.



When a unit is placed in multidrop mode its manual user interface is automatically locked! It can be unlocked with the command XXXJ=U <CR>, where XXX is the multidrop address.

10.2 Command Structure

Protocols are the set of commands that define all possible communications with the sensor. The commands are described in the following sections along with their associated ASCII command characters and related message format information. Types of commands include the following:

1. A request for the current value of a parameter
2. A change in the setting of a parameter
3. Defining the information contents of a string (either continuously output or periodically polled at the option of the user)

The sensor will respond to every command with either an "acknowledge" or a "not acknowledge" string. Acknowledge strings begin with the exclamation mark (!) and are either a confirmation of a set command or a request of a parameter value. If the unit is in multidrop mode the 3-digit address has to be sent out before the exclamation mark.

For a new parameter setting by the user, a range check of allowed values will be performed by the Endurance firmware. If an out of range for a parameter is detected by the firmware, a Range Error is indicated and transmitted back by the Endurance sensor.



All commands via RS485 or LAN/Ethernet interface have to be entered in upper case (capital) letters.

Programming Guide

After transmitting one command via RS485 or LAN/Ethernet link, the sender has to wait for the response from the Endurance device before sending a subsequent one. The response time from the Endurance device back to the sender depends on the following factors:

- Operation mode of the Endurance sensor (single or multidrop), without or with leading device address bytes in the response string
- Chosen transmission link (RS485 or LAN/Ethernet) with different transmission speed
 - RS485: 1200 bps – 115.200 bps (~ 120 char/sec – 11.520 char/sec)
 - LAN/Ethernet: max. 100 Mbit/sec (~ 10.000.000 char/sec)

An asterisk * will be transmitted back to the sender in the event of an “illegal” instruction. An illegal instruction is considered to be one of the following:

- An “out-of-range” parameter value
- Any not defined command character or value entered in the incorrect format (syntax error)
- Lower case character(s) entered (all characters must be upper case)

10.3 Transfer Modes

The protocol allows the use of two different modes: the Poll Mode and the Burst Mode

10.3.1 Poll Mode

The current value of any individual parameter can be requested by the host. The unit responds once with the value at the selected baud rate. Additionally, the user-defined output string can be polled.

10.3.2 Burst Mode

The Endurance sensor transmits the user-defined output string continuously via RS485 (at selected baud rate) or LAN/Ethernet (max. 100Mbps) in a user defined burst interval time. A user defined burst string may contain several parameters in the user defined order.

The string may contain the following parameters:

1. Temperature unit (\$=U) in °C or °F
2. Target temperature (\$=T[2C-mode], \$=W[wide band], \$=N[narrow band]) in °C or °F
3. Power (\$=Q[wide band], \$=R[narrow band]) in mW
4. Emissivity (\$=E) in the range from 0.0 – 1.10
5. Transmissivity (\$=XG) in the range from 0.0 – 1.10
6. Attenuation (\$=B) in the range from 0 – 100%
7. Average time (\$=G) in the range from 0.0 – 300.0 sec
8. Peak hold time (\$=P) in the range from 0.0 – 300.0 sec
9. Valley hold time (\$=F) in the range from 0.0 – 300.0 sec
10. Internal ambient temperature (\$=I) in the range from 0.0 – 100.0 in °C or °F
11. Top of temperature range (\$=H) in the range from 0.0 – 9999.0 in °C or °F

An example string for the burst request command \$=UTQEGH<CR>

The cyclically transmitted Endurance sensor string is: C T1250.5 Q400.5 E1.00 G7.5 H3000.0 <CR><LF>

10.4 Command List

The table below describes the available commands via RS485 or LAN/Ethernet interface.

Description	Char	Format (2)	P (1)	B (1)	S (1)	Legal Values	Factory Default
Burst string format	\$	(3)	√		√	(3)	UTSI
Show list of commands	?		√				
Measured attenuation	B	nn - nnn	√	√		00 to 100%	
Burst speed	BS	n - nnnnn	√		√	5 msec – 10 sec (5 – 10000)	50 msec
Baud rate (6)	D	nnn - nnnn	√		√	012 = 1200 baud 024 = 2400 baud 096 = 9600 baud 192 = 19200 baud 384 = 38400 baud 576 = 57600 baud 1152 = 115200 baud	38400 baud
Digital filter	DF	n	√		√	0 = OFF, 1 = ON	0
DHCP (Dyn. Host Config. Protocol)	DHCP	n	√		√	0 = OFF, 1 = ON	0
Emissivity	E	n.nn	√	√	√	0.10 – 1.10	1.00
Error Codes (9)	EC	nnnnnnnn	√			0000 – FFFF (Hex)	
Valley hold time (4)	F	n.n - nnn.n	√	√	√	0.0 – 300.0 sec (300 s = ∞)	0.0
Average time (4)	G	n.n - nnn.n	√	√	√	0.0 – 300.0 sec (300 s = ∞)	0.0
Gateway Address	GW	nnn.nnn.nnn.nnn	√		√	0.0.0.0 - 255.255.255.255	192.168.42.1
Top of mA temperature range	H	n.n - nnnn.n	√	√	√	0.0 – 9999.0 (°C or °F)	Upper end of sensor range
Sensor internal ambient	I	n.n - nnn.n	√	√		0.0 – 999.0 (°C or °F)	
IP Address	IP	nnn.nnn.nnn.nnn	√		√	0.0.0.1 - 255.255.255.255	192.168.42.132
Switch panel lock	J	X	√		√	L = Locked U = Unlocked	Unlocked
Relay alarm output control	K	n	√		√	0 = off 1 = on 2 = Normally Open 3 = Normally Closed	2
Bottom of mA temperature range	L	n.n - nnnn.n	√	√	√	0.0 – 9999.0 (°C or °F)	Lower end of sensor range
Mode-ER series	M	n	√	√	√	1 = 1 - color 2 = 2 - color	2
MAC Hardware Address	MAC	nnnnnnnnnn	√			e.g. 001d8d2aaa01	Set at factory calibration
Target temp – 1-color narrow	N	n.n - nnnn.n	√	√			
Net Mask	NM	nnn.nnn.nnn.nnn	√		√	0.0.0.1 - 255.255.255.255	255.255.255.0
Output current	O	nn	√		√	00 = controlled by unit 02 = under range 21 = over range 00 – 20 = current in mA	00

Programming Guide

Description	Char	Format (2)	P (1)	B (1)	S (1)	Legal Values	Factory Default
Peak hold time (4)	P	n.n - nnn.n	√	√	√	0.0 – 300.0 sec (300 s = ∞)	0.0
IP Portaddress	PORT	n - nnnnn	√		√	1 - 65535	6363
Wide Power	Q	n.nnnnnnn	√	√			
Narrow power	R	n.nnnnnnn	√	√			
Video relative reticle diameter	RC	n.n - nn.nn	√				
Video relative reticle X-position	RX	n.n - nn.nn	√				
Video relative reticle Y-position	RY	n.n - nn.nn	√				
Slope	S	n.nnn	√	√	√	0.850 – 1.150	1.000
Set target temperature	STT	n.n - nnnn.n	√		√	0.0 – 9999.0 (5)	Set at factory calibration
Target Temperature 2-color	T	n.n - nnnn.n	√	√			
Terminator resistor	TR	n	√		√	0 = OFF, 1 = ON	0 = OFF
TCP/IP time out interval	TTI	n - nnn	√		√	0 = ∞, 1 – 240 sec	0
Temperature units (scale)	U	X	√	√	√	C or F	non-US: C
Poll/burst mode	V	X	√		√	B = Burst, P = Polled	P = Polled
Target temp: 1-color wide	W	n.n - nnnn.n	√	√		(5)	
Web server ON/OFF	WS	n	√		√	0 = OFF, 1 = ON	0 = OFF
Burst string contents (3)	X\$		√				
Multidrop address	XA	nnn	√		√	000 to 032	000
Low temperature limit	XB	n.n - nnnn.n	√			0.0–9999.0 (5)	Set at factory calibration
Deadband (7)	XD	nn	√		√	01 – 55 in °C / 01 – 99 in °F	02
Restore factory defaults	XF				√		
Transmissivity	XG	n.nn	√	√	√	0.10 – 1.10	1.00
High temperature limit	XH	n.n - nnnn.n	√			0.0–9999.0 (5)	Set at factory calibration
Sensor initialization	XI	n	√	√	√	0 = flag reset, 1 = flag set	1
LASER / LED / Video ON / OFF	XL	n	√		√	0 = OFF, 1 = ON	0 = OFF
Sensor model type	XM	X	√			L = Low Temp., H = Hi Temp	Set at factory calibration
0 - 20 mA / 4-20 mA analog output	XO	n	√		√	0 = 0 - 20 mA, 4 = 4 - 20 mA	4
Sensor firmware revision no.	XR	Xn	√			e.g. 1.02.11	Set at factory calibration
Sensor analog part revision no.	XRA	Xn	√			e.g. 1.02.01	Set at factory calibration
Setpoint / Relay function	XS	n.n - nnnn.n	√		√	0.0 to 3200.0°C / 5792.0°F (8)	0.0
Trigger	XT	N	√	√		0 = inactive, 1 = active	0
Identify unit	XU	Varies	√			e.g. E1RL-F2-V-0-0	Set at factory calibration
Sensor serial number	XV	nnnnnnnn	√			e.g. 31712345 (8 digits)	Set at factory calibration
Attenuation to activate relay	Y	nn	√	√	√	0 to 95% energy	95%
Attenuation for failsafe	Z	nn	√	√	√	0 to 99% energy reduction	95%

Programming Guide

Notes:															
(1) Commands may appear as Polled for (queried), Burst string item or Set command															
(2) n = number, X = uppercase letter.															
(3) see section 10.3.2 Burst Mode, page 50															
(4) Setting either Average, Peak Hold or Valley Hold, sets non concerned signal post processing settings to factory default value															
(5) In current scale °C or °F															
(6) The sensor restarts after a baud rate change. (Command is not allowed in multidrop mode.)															
(7) No effect if relay in alarm mode.															
(8) Non-zero setpoint value puts unit in setpoint mode. Setpoint is in current scale °C or °F and must be within unit's temperature range.															
(9) Error Codes returned out of ?EC-Command (16 Bit-Word, 0000000000000000 – 1111111111111111)															
2 ¹⁵	2 ¹⁴	2 ¹³	2 ¹²	2 ¹¹	2 ¹⁰	2 ⁹	2 ⁸	2 ⁷	2 ⁶	2 ⁵	2 ⁴	2 ³	2 ²	2 ¹	2 ⁰
Alarm detection	Narrow band temperature over range	Narrow band temperature under range	Wide band temperature over range	Wide band temperature under range	Two-color temperature over range	Two-color temperature under range	Attenuation > 95% ("dirty window")** (1)	Attenuation too high (> 95%) (1)	Energy too low	Narrow band detector failure	Wide band detector failure	Internal temperature under range	Internal temperature over range	Heater control temperature under range	Heater control temperature over range

Table 4 Command List

10.5 Command Examples

Description	HOST	SENSOR	HOST	WHERE USED (1)		
	Query →	Answer	Set →	P	B	S
Burst string format	001?\$	001!\$UTSI	001\$=UTSI	√		√
Show list of commands	001?			√		
Measured attenuation	001?B	001!B12		√	√	
Baud rate	001?D	001!D384	001D=384			√
Emissivity	001?E	001!E0.95	001E=0.95	√	√	√
Average time	001?G	001!G1.2	001G=1.2	√	√	√
Top of mA range	001?H	001!H2000.0	001H=2000.0	√	√	√
Sensor internal ambient	001?I	001!I37.9		√	√	
Switch panel lock	001?J	001!JL	001J=L	√		√
Relay alarm output control	001?K	001!K0	001K=0	√		√
Bottom of mA range	001?L	001!L1200.0	001L=1200.0	√	√	√
Mode – ER series	001?M	001!M1	001M=1	√	√	√
Target temperature, 1-color narrow	001?N	001!N1158.0			√	
Output current	001?O	001!O10	001O=10	√	√	√
Peak hold time	001?P	001!P5.6	001P=5.6	√	√	√
Power	001?Q	001!Q36.102000		√	√	
Narrow Power	001?R	001!R2.890000		√	√	
Slope	001?S	001!S0.850	001S=0.850	√	√	√
Target temperature, ER series 2-color	001?T	001!T1225.0		√	√	
Temperature units	001?U	001!UC	001U=C	√	√	√
Poll/Burst mode		001!VP	001V=P			√

Programming Guide

Target temperature, 1-color wide	001?W	001!W1210.0		√	√	
Burst string contents	001?X\$	001!UC T1200.5 S0.850 I37.9		√		
Multidrop address	001?XA	001!XA013	001XA=013	√	√	√
Low temperature limit	001?XB	001!XB400.0		√		
Deadband	001?XD	001!XD12	001XD=12	√		√
LASER / LED / Video ON / OFF	001?XL	001!XL1	001XL=1	√		√

Table 5: Command Examples

P = Poll Mode (Request for a parameters) B = Burst Mode (continuous sending of parameters in the burst string)
S = Set (Command for setting a parameters) N = Notification (Acknowledgment for setting a parameter)



The given examples are related to a unit in a multidrop network, addressed with address 001. Stand-alone units (address 000) don't have an address information in the command.

11 Maintenance

Our sales representatives and customer service are always at your disposal for questions regarding application assistance, calibration, repair, and solutions to specific problems. Please contact your local sales representative if you need assistance. In many cases, problems can be solved over the telephone. If you need to return equipment for servicing, calibration, or repair, please contact our Service Department before shipping. Phone numbers are listed at the beginning of this document.

11.1 Troubleshooting Minor Problems

Symptom	Probable Cause	Solution
No output	No power to instrument	Check the power supply
Erroneous temperature	Faulty sensor cable	Verify cable continuity
Erroneous temperature	Field of view obstruction	Remove the obstruction
Erroneous temperature	Window lens	Clean the lens
Erroneous temperature	Wrong slope or emissivity	Correct the setting
Temperature fluctuates	Wrong signal processing	Correct Peak Hold or Average settings

Table 6: Troubleshooting

11.2 Fail-Safe Operation

The Fail-Safe system is designed to alert the operator and provide a safe output in case of any system failure. Basically, it is designed to shut down the process in the event of a set-up error, system error, or a failure in the sensor electronics.



The Fail-Safe circuit should never be relied on exclusively to protect critical heating processes. Other safety devices should also be used to supplement this function!

11.2.1 Fail-Safe Error Codes (displayed or transmitted via electrical interface)

When an error or failure does occur, the temperature display indicates the possible failure area, and the output circuits automatically adjust to their lowest or highest preset level. The following table shows the values displayed on the 7-segment temperature display and transmitted over the RS485 or LAN / Ethernet interface.

Maintenance

Condition	2-Color	1-Color (wide band)**	1-Color* (narrow band)**
Heater control temperature over range	ECHH	ECHH	ECHH
Heater control temperature under range	ECUU	ECUU	ECUU
Internal temperature over range	EIHH	EIHH	EIHH
Internal temperature under range	EIUU	EIUU	EIUU
Wide band detector failure	EHHH	EHHH	<temperature>
Narrow band detector failure	EHHH	<temperature>	EHHH
Energy too low	EUUU	<temperature>	<temperature>
Attenuation too high (>95%)***	EAAA	<temperature>	<temperature>
Attenuation too high >95% ("dirty lens", relay will go to "alarm" state)***	<temperature>	<temperature>	<temperature>
2-color temperature under range	EUUU	<temperature>	<temperature>
2-color temperature over range	EHHH	<temperature>	<temperature>
Wide band temperature under range	<temperature>	EUUU	<temperature>
Wide band temperature over range	<temperature>	EHHH	<temperature>
Narrow band temperature under range	<temperature>	<temperature>	EUUU
Narrow band temperature over range	<temperature>	<temperature>	EHHH

* only available via RS485 or LAN / Ethernet command

** Wide and narrow band stands for the first and the second wavelength in 2-color mode

*** Note that the activation levels for these conditions may be set to different values. (e.g., "dirty lens" at 95%, EAAA at 98%)

Table 7: Fail-safe Error Codes

11.2.2 Analog Output (Current) values in dependence of Fail-Safe Error Codes

The relay is controlled by the temperature selected on the display. If any failsafe code appears on the display, the relay changes to the "abnormal" state. The exception is the "dirty window" condition. This causes the relay to change state, leaving a normal numerical temperature output.

Error Code	0 – 20 mA Output	4 – 20 mA Output
no error	according to temperature	according to temperature
ECHH	21 to 24 mA	21 to 24 mA
ECUU	0 mA	2 to 3 mA
EIHH	21 to 24 mA	21 to 24 mA
EIUU	0 mA	2 to 3 mA
EUUU	0 mA	2 to 3 mA
EHHH	21 to 24 mA	21 to 24 mA
EAAA	0 mA	2 to 3 mA

Table 8: Current Output Values in accordance to an Error

If two or more errors occur simultaneously, the error with the highest priority overrules the lower priority errors. The highest priority error will be displayed on the 7-segment temperature display and the assigned analog output (current) value (see Table 8) will be set. For instance, in 2-color mode, if the internal ambient temperature is over the limit and the attenuation is too high, the unit outputs EHH to the temperature display and sets an analog output current of 21 mA on the analog current loop output lines. However, since 2-color wide band and narrow band temperatures may all be presented simultaneously through RS485 or LAN / Ethernet interface, their over and under range conditions are independent.

Following order shows the priorities of the possible failsafe conditions:

1. Heater control temperature over range
2. Heater control temperature under range
3. Internal temperature over range
4. Internal temperature under range
5. Wide band detector failure
6. Narrow band detector failure
7. Energy too low
8. Attenuation too high (> 95%)
9. Attenuation > 95% ("dirty window")
10. Two-color temperature under range
11. Two-color temperature over range
12. Wide band temperature under range
13. Wide band temperature over range
14. Narrow band temperature under range
15. Narrow band temperature over range

highest priority



lowest priority

Examples of failsafe conditions:

1. One-color temperature is selected to show on the temperature display. Two-color temperature is transmitted in burst mode. Wide band temperature is under range. Two-color temperature is 999°C.

Outputs:

Temperature Display:	EUUU
RS485 or LAN/Ethernet:	C T999.0
Analog Output:	2 to 3 mA
Relay:	abnormal state

2. Two-color temperature is selected to show on the temperature display. All three temperatures are transmitted in burst mode. Two-color temperature is 1021.0°C. Wide band temperature is 703.0°C. Narrow band temperature is 685.0°C. Attenuation is above 95%, the "dirty window" threshold.

Outputs:

Temperature Display:	1021.0
RS485 or LAN/Ethernet:	C T1021.0 W703.0 N685.0
Analog Output:	scaled to temperature, between 4 and 20 mA
Relay:	abnormal state

Maintenance

11.3 Cleaning the Lens

Keep the lens clean at all times. Any foreign matter on the window will affect 1-color measurement accuracy and may affect two-color accuracy. However, care should be taken when cleaning the lens. To clean the window, do the following:

1. Lightly blow off loose particles with “canned” air (used for cleaning computer equipment) or a small squeeze bellows (used for cleaning camera lenses).
2. Gently brush off any remaining particles with a soft camel hair brush or a soft lens tissue (available from camera supply stores).
3. Clean remaining “dirt” using a cotton swab or soft lens tissue dampened in distilled water. Do not scratch the surface.

For finger prints or other grease, use any of the following:

- Denatured alcohol
- Ethanol

Apply one of the above to the lens. Wipe gently with a soft, clean cloth until you see colors on the surface, then allow to air dry. Do not wipe the surface dry, this may scratch the surface.

If silicones (used in hand creams) get on the window, gently wipe the surface with Hexane. Allow to air dry.



Do not use any ammonia or any cleaners containing ammonia to clean the lens. This may result in permanent damage to the lens' surface!

11.4 Changing the Window

Sometimes extremely harsh environments can cause damage to the window.

A replacement protective front window (E-PW) is available.

To replace the sensor's protective front window, complete the following:

1. With a very small flat-bladed screw driver (e.g., a jeweler's screwdriver), pry out the rubberized Buna-N 70 durometer O-ring. The O-ring is set in a groove in front of the window.
2. Turn the sensor face down (window pointing down), and the window should fall out.
3. Turn the sensor face up and insert the new window. (Make sure both sides of the window are clean.)
4. Replace the O-ring.



If you use a fine-bladed knife to remove the O-ring, be careful not to cut or sever the ring.

12 Appendix

12.1 Determination of Slope (for 2 – color operation)

The following slope settings are approximate and will vary depending on the metal alloy and surface finish, as well as the application. These are supplied here as examples.

Set the slope to approximately **1.000** for measuring the following metals with oxidized surfaces:

- Stainless Steel
- Iron
- Cobalt
- Nickel
- Steel

Set the slope to approximately **1.060** for measuring the following metals with smooth, clean, unoxidized surfaces:

- Iron
- Stainless Steel
- Cobalt
- Molybdenum
- Nickel
- Rhodium
- Steel
- Platinum
- Tantalum
- Tungsten

Molten iron also has an approximate slope setting of 1.060.

How to determine slope?

The most effective way to determine and adjust the slope is to take the temperature of the material using a probe sensor such as an RTD, thermocouple, or other suitable method. Once you determine the actual temperature, adjust the slope setting until the sensor's temperature reads the same as the actual temperature reading. This is the correct slope for the measured material.

12.2 Percentage of allowed signal reduction

Figure 33 and Figure 34 show each sensor model's percentage of allowed signal reduction at all temperatures. Refer to these graphs to estimate what percentage of target area must be visible to the sensor at temperatures below the minimum temperature (95% attenuation) as shown in Table 1: Models of this manual.

Appendix

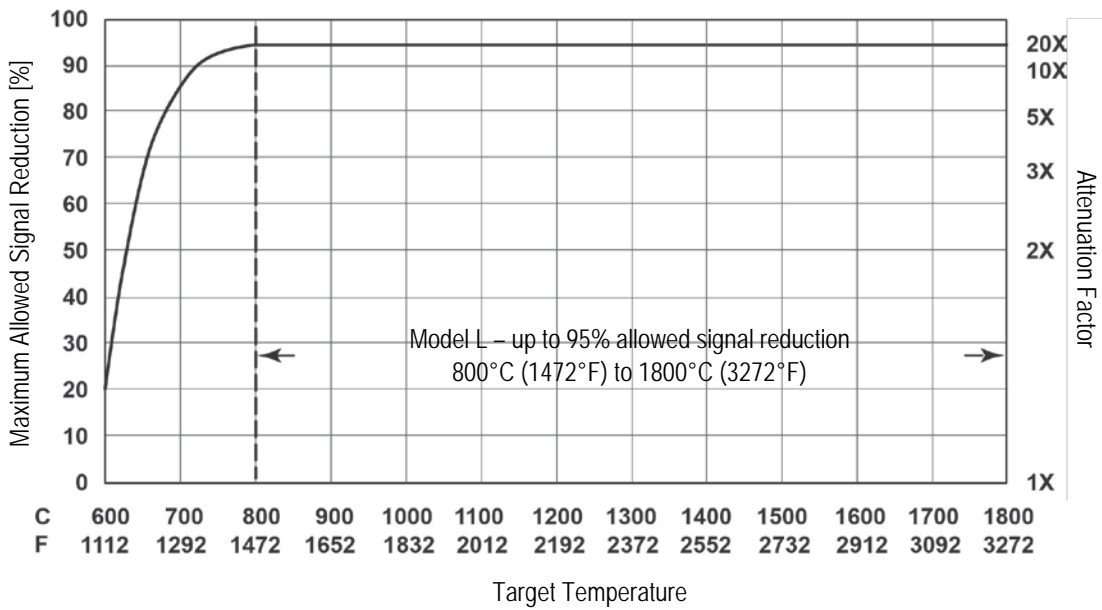

Figure 33: Model L Percentage of Allowed Signal Reduction

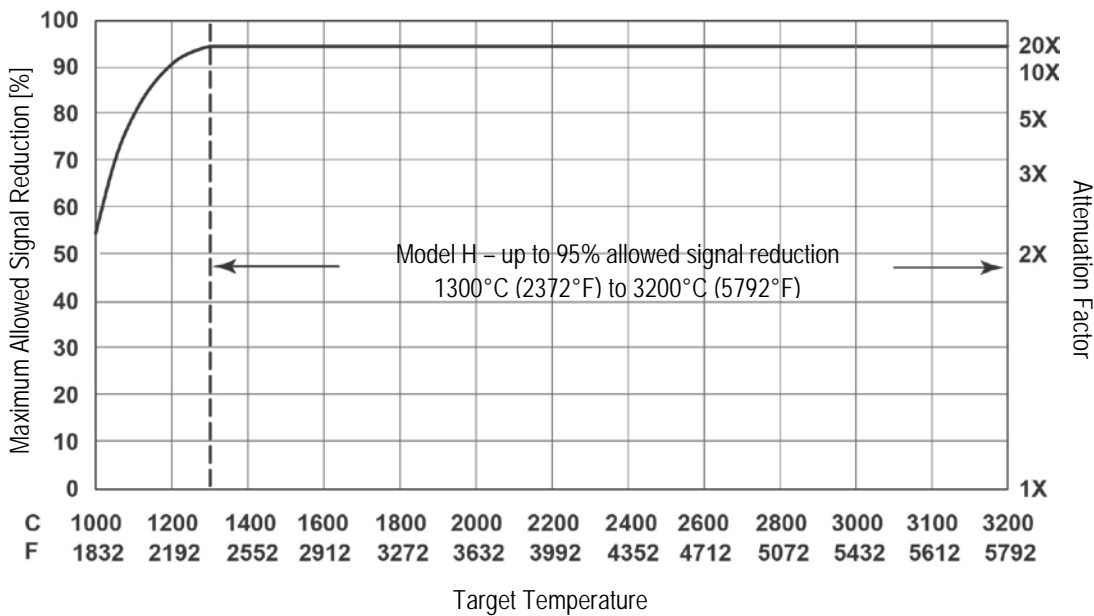

Figure 34: Model H Percentage of Allowed Signal Reduction

12.3 Determination of Emissivity (for 1-color operation)

Emissivity is a measure of an object's ability to absorb and emit infrared energy. It can have a value between 0 and 1.0. For example a mirror has an emissivity of 0.1, while the so-called "Blackbody" reaches an emissivity value of 1.0. If a higher than actual emissivity value is set, the output will read low, provided the target temperature is above its ambient temperature. For example, if you have set 0.95 and the actual emissivity is 0.9, the temperature reading will be lower than the true temperature.

An object's emissivity can be determined by one of the following methods:

1. Determine the actual temperature of the material using an RTD (PT100), a thermocouple, or any other suitable method. Next, measure the object's temperature and adjust emissivity setting until the correct temperature value is reached. This is the correct emissivity for the measured material.
2. If possible, apply flat black paint to a portion of the surface of the object. The emissivity of the paint must be above 0.98. Next, measure the temperature of the painted area using an emissivity setting of 0.98. Finally, measure the temperature of an adjacent area on the object and adjust the emissivity until the same temperature is reached. This is the correct emissivity for the measured material.

12.4 Typical Emissivity Values

The following table provides a brief reference guide for determining emissivity and can be used when one of the above methods is not practical. Emissivity values shown in the table are only approximate, since several parameters may affect the emissivity of a material. These include the following:

1. Temperature
2. Angle of measurement
3. Geometry (plane, concave, convex)
4. Thickness
5. Surface quality (polished, rough, oxidized, sandblasted)
6. Spectral range of measurement
7. Transmissivity (e.g. thin films plastics)

Appendix

EMISSION AT 1 μM FOR METALS	
Material	Emissivity
Aluminum	
unoxidized	0.1-0.2
oxidized	0.4
roughened	0.2-0.8
polished	0.1-0.2
Brass	
polished	0.1-0.3
Burnished	0.6
Chromium	0.4
Copper	
polished	0.05
roughened	0.05-0.2
oxidized	0.2-0.8
Gold	0.3
Haynes	
Alloy	0.5-0.9
Inconel	
oxidized	0.4-0.9
sandblasted	0.3-0.4
electropolished	0.2-0.5
Iron	
oxidized	0.4-0.8
unoxidized	0.35
molten	0.35

EMISSION AT 1 μM FOR METALS	
Material	Emissivity
Iron, cast	
oxidized	0.7-0.9
unoxidized	0.35
molten	0.35
Magnesium	0.3-0.8
Molybdenum	
oxidized	0.5-0.9
unoxidized	0.25-0.35
Monel (Ni-Cu)	0.3
Nickel	
oxidized	0.8-0.9
electrolytic	0.2-0.4
Silver	0.04
Steel	
cold rolled	0.8-0.9
polished sheet	0.35
molten	0.35
oxidized	0.8-0.9
stainless	0.35
Tin (unoxidized)	0.25
Titanium	
polished	0.5-0.75
Zinc	
oxidized	0.6
polished	0.5

Table 9: Typical Emissivity Values (Metals)

EMISSION AT 1 μM FOR NON-METALS	
Material	Emissivity
Asbestos	0.9
Ceramic	0.4
Concrete	0.65
Carbon	
unoxidized	0.8-0.95
graphite	0.8-0.9

Table 10: Typical Emissivity Values (Non-Metals)