

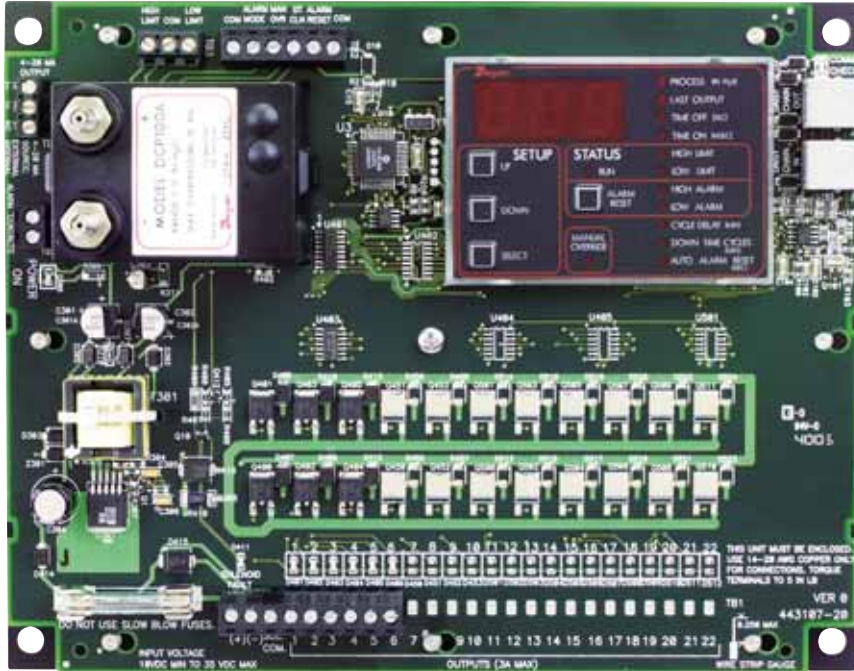

Series DCT1000DC Dust Collector Timer Controller

Specifications – Installation and Operating Instructions



Thank you for purchasing the Dwyer® DCT1000DC Dust Collector Timer Controller. You have selected a state of the art dust collector timer control that will provide years of dependable operation and service.

The Dwyer® DCT1000DC Dust Collector Timer Controller was designed to be used with pulse-jet type dust collectors for on-demand or continuous cleaning applications.

Continuous cleaning applications do not require external inputs and can be used for time based "on-demand" cleaning through use of the cycle delay feature.

For on-demand applications, the plug-in pressure modules (DCP100A/200A) can be used to take full advantage of all the features the DCT1000DC offers, or an external pressure switch can be used for High/Low limit control.

The Dwyer® DCT1000DC was designed so that it is easy to use, thus allowing for a quick and easy start up for your dust control applications. The contents inside this installation and operating manual will guide you through the features of the DCT1000DC and how they can be applied to get the most out of your dust control requirements.

SPECIFICATIONS

DCT1000DC Timer Controller:

Output Channels: 6, 10, & 22 channels.

Power Requirements: 10 - 30 VDC.

Solenoid Supply: 3A maximum per channel.

Fuse: 3A @ 250 VAC.

Temperature Limits: -40 to 140°F (-40 to 60°C).

Storage Temperature Limits: -40 to 176°F (-40 to 80°C).

On Time: 10 msec to 600 msec, 10 msec steps.

On Time Accuracy: ± 10 msec.

Off Time: 1 second to 255 seconds, 1 second steps.

Off Time Accuracy: ±1% of the value or ±50 msec, whichever is greater.

Weight: 1 lb 3.0 oz (538.6 g).

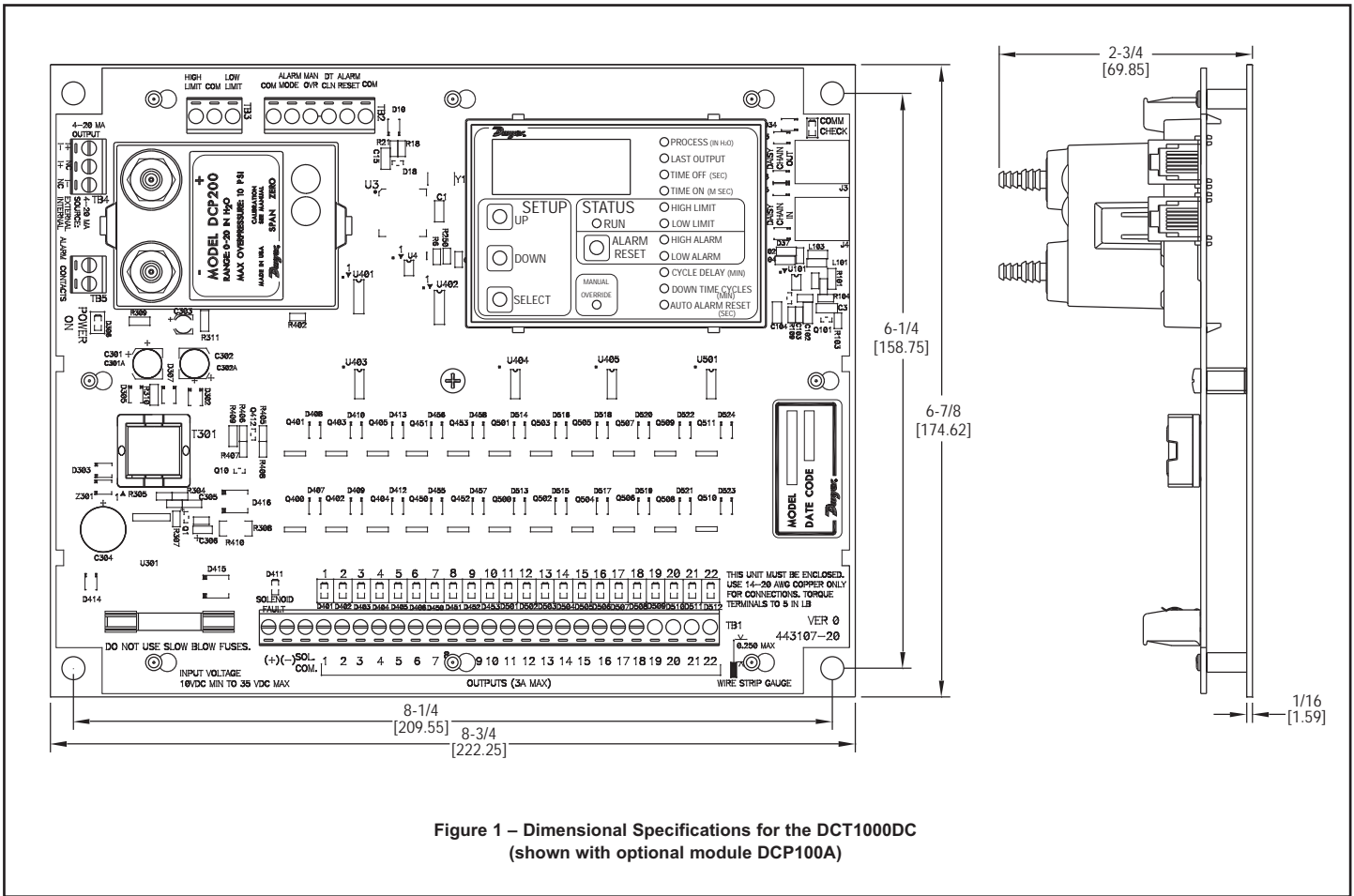
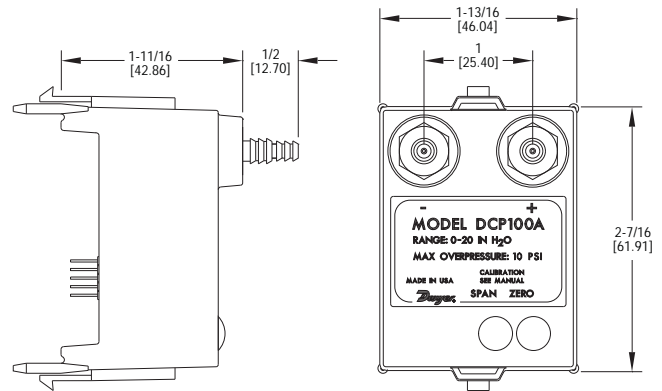

Figure 1 – Dimensional Specifications for the DCT1000DC (shown with optional module DCP100A)



The Dwyer® DCP100A or DCP200A pressure modules are designed exclusively for use with the DCT1000DC Dust Collector Timer Controller boards for on-demand cleaning requirements. These series of modules are available in 10" w.c. [2.49 kPa] or 20" w.c. [4.98 kPa] ranges, which allow for differential process pressure measurement as indicated on the display of the master controller. An isolated 4-20 mA readout channel is provided for remote pressure display. The 4-20 mA output may be wired either for use with an external power supply and indicator or using the isolated on-board 24 volt power supply to power the loop.

SPECIFICATIONS

- Pressure Ranges:** 10 in w.c. or 20 in w.c.
- Temperature Limits:** -40 to 140°F (-40 to 60°C).
- Pressure Limit:** 10 psi (68.95 kPa).
- Pressure Limit (differential):** 10 psi (68.95 kPa).
- Accuracy:** ±1.5% F.S. @ 73°F (22.8°C).
- Output Signal:** 4-20 mA.
- Alarm Contacts:** 1.5A inductive load, 3A resistive load @ 30 VAC or 40 VDC.
- Process Connections:** Two barbed connections for use with 1/8" (3.18 mm) or 3/16" (4.76 mm) I.D. tubing.
- Weight:** 5.5 oz (155.9 g).

Table of Contents	Page No.
Figure 1 Dimensional Specifications	2
1.0 Installing the DCT1000DC	3
1.1 Power Requirements	3
1.2 DCT1000DC Terminal Connections	3
1.2.1 External Pressure Connection	3
1.2.2 Manual Override Switch Connection	4
1.2.3 Down Time Clean Connection	4
1.2.4 Connecting Multiple Timer Boards	4
1.2.5 Continuous Cycle Mode	4
Figure 2 Wiring Connections	4
1.3 DCP Installation	5
Figure 3 DCP Installation	5
1.3.1 Location	5
1.3.2 Pressure Model Locking Pins	5
1.3.3 Connecting DCP to Master Controller	5
1.3.4 DCP Connections	5
1.3.5 DCP Maintenance	5
1.4 Alarm Mode Switch Connection	5
1.4.1 Alarm Reset Switch Connection	5
1.4.2 Connecting the 4-20 mA Loop	5
1.4.3 Connecting the Alarm Relay	6
1.5 Three Position Selection Switch Wiring	6
2.0 Programming the DCT1000DC Master Controller	6
2.1 Last Output Setup	6
2.2 Time Off Setup	6
2.3 Time On Setup	6
2.4 High Limit Setup	7
2.5 Low Limit Setup	7
2.6 High Alarm Setup	7
2.7 Low Alarm Setup	7
2.8 Cycle Delay Setup	7
2.9 Down Time Cycles Setup	7
2.10 Auto Alarm Reset Setup	7
3.0 Maintenance Support and Diagnostics	7
3.1 Restoring Factory Defaults	7
3.2 Power Indicator	7
3.3 Active Channel Indicator	7
3.4 Comm Check Indicator	7
3.5 Error Codes	8
4.0 Glossary of Terms	8
Customer Service Phone Number	8

1.0 Installing the DCT1000DC

The open frame design of the DCT1000DC will require an enclosure that meets appropriate safety and local code requirements. For optimal performance, the enclosure should also protect the controller from dirt, water and direct sunlight. There are no special orientation requirements, and the controller mounts easily using the mounting holes on the factory installed base plate.



Caution: Do not run control wires, communication cables, or other class 2 wiring in the same conduit as power leads. The system may malfunction if class 2 wiring is run together with power conductors.

1.1 Power Requirements

The DCT1000DC requires 10 to 30 VDC supply power. The solenoids must be matched to supply voltage. **DO NOT** exceed 35V, because transient suppression circuitry will begin to draw high current.

1.2 DCT1000DC Terminal Connections

The line and solenoid connections are located at the lower edge of the board below the plastic guard. The terminal block is a “Euro” style connector system that clamps the wire within the connector body. The connector will accept wire sizes from 14 to 22 AWG. The wire should be stripped to no more than 0.25 inches to avoid shorts. To assist you in determining the proper strip length, a strip gauge is provided at the lower right corner of the board. The connector system used on the DCT1000DC is specified for single connection but you can piggyback to a single lug provided that local codes allow for this and good workmanship practices are followed. To power up the master controller and the channel expander, connect line power to (+) and (-) (see Dimensional Specifications, Figure 1). Connect the solenoids between the selected output and the solenoid common. Solenoid common and (+) are internally connected. Switches connected to the control inputs at the top of the board must be isolated contacts connected only to the relevant terminal and to the common terminals. The following subparagraphs describe the external switch connections. Refer to figure 2 for switch connection illustration.

1.2.1 External Pressure Connection

The controller may be used with an external pressure limit switch or sensor to provide demand-cleaning operation. The high limit and low limit inputs may be used for this purpose. A simple on-off system can be established with a single pressure switch connected to the high limit input. In this on-demand mode, time on, time off, and cycle delay may be programmed to define the cleaning cycle. A three pin terminal block (TB3) provides connection for external high and low limit switches (see Figure 2 on the next page). These switches must be isolated contacts. The common line must not be connected to equipment ground or protective ground, since these may introduce electrical noise and cause improper operation or possible damage to the control board. The operation of these inputs are summarized as follows (see next page):

Current Operation	Low Limit Switch	High Limit Switch	Next Operation
Hold	Open	Open	Hold
Hold or Run	X	Closed	Run
Hold	∅	Open	Hold
Hold	Closed	∅	Run
Run	Closed	≠	Run
Hold	Closed	∅	Run
Run	≠	Open	Hold

∅ Transition from open to closed

≠Transition closed to open

X Either open or closed

Note: If a DCP100A or DCP200A pressure module is installed in the master controller, the switching functions are ignored.

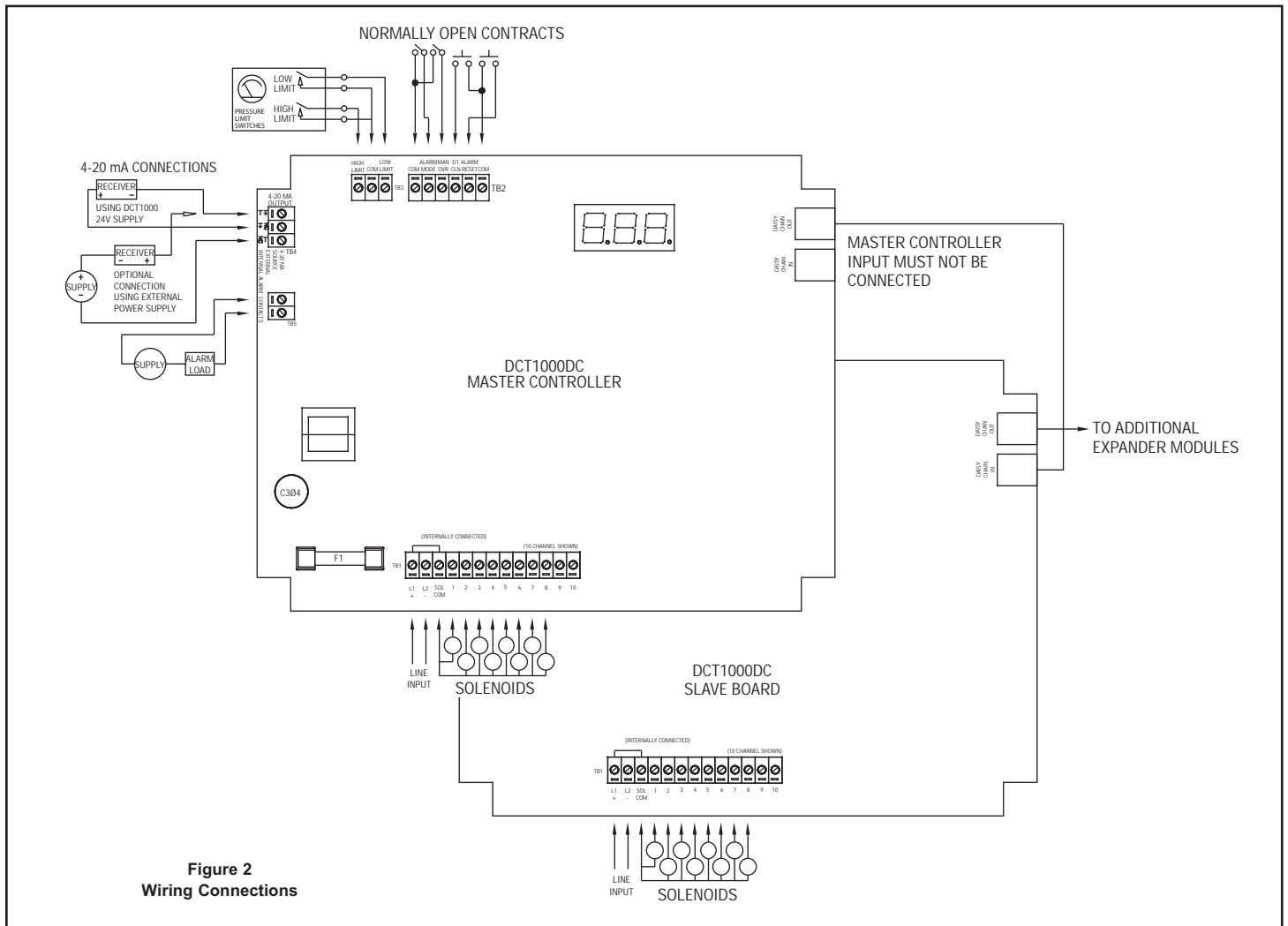

Figure 2
Wiring Connections

1.2.2 Manual Override Switch Connection

The manual override function allows the system to be set to the run mode regardless of other conditions. This mode is enabled when the manual override terminal and common are connected. It is disabled when they are disconnected. If the controller is to be run in continuous mode, a jumper wire may be wired across these terminals. When manual override is needed on a periodic basis, wire a SPST toggle switch between the manual override terminal and the common terminal.

1.2.3 Down Time Clean Connection

The down time clean operation forces the system into a run cycle for a programmed length of time between 0 – 255 minutes. The operation is initiated by connecting the down time clean terminal to a common terminal. This function is best accomplished through use of an external normally open switch.

1.2.4 Connecting Multiple Timer Boards

The DCT1000DC is available with up to 22 channels on single unit. Where the installation requires more than 22 channels, the system may be expanded up to 255 channels by daisy chaining multiple controller boards. The system will automatically detect the total number of channels and operate as a single system.

To connect multiple boards together you will need one or more jumper cables, Model DCA, available from Dwyer Instruments, Inc. in various lengths. These are connected to the telephone-style connectors at the upper right side of the controller boards. One board in the system is designated as the master. Subsequent units become slave boards. The master controller is the board at the head of the chain having no connection to its daisy chain connector. Connect the cable from the daisy chain out connector on connector on the master controller to the daisy

chain in connector of the first slave board. Subsequent slave boards are connected from the daisy chain out connector on one board to the daisy chain in on the next. The master controller must then be configured to the system requirements. The display and status indicators of slave boards are automatically disabled.



Caution: Do not use telephone jumper cables. These have a “twist” in the connection and may damage the controllers. Cables designed for use with the DCT1000DC are available from Dwyer Instruments Inc.

1.2.5 Continuous Cycle Mode

The DCT1000DC has several operating modes available for different applications. Starting with the most basic mode, it is capable of operating in a continuous cleaning cycle. This can be initiated by either placing a jumper between the high limit input and the common, or the manual override input to the common connection. Controlling this cycle are three setup parameters: time off, time on, and cycle delay. Time on and time off specifically deal with the solenoid on time and the time interval between the end of the on pulse and the start of the next. The cycle delay allows a delay of up to 255 minutes to be programmed between the end of one complete cleaning cycle and the beginning of the next. This allows additional options for defining a cleaning profile.

1.4.3 Connecting the Alarm Relay

With the pressure module installed, a relay contact is provided for controlling an external alarm. This relay is a single form-A contact. It is activated when either the high alarm threshold is exceeded, or the pressure drops below the low alarm threshold. The connection is made at the two-pin connector TB5. See Figure 2 Wiring Connections

1.3 DCP Installation



Caution: Prior to installing the DCP100A/200A please review the operating specifications carefully.

Some operating systems, especially in pneumatic conveying applications, may see static pressure or vacuum conditions that exceed the capability of the DCP100A/200A pressure module.

1.3.1 Location

The system should be located in an enclosure that meets relevant safety standards and electrical codes. There are no other special orientation requirements as the pressure module is not orientation sensitive. Care should be observed when routing the air hoses to ensure that any potential condensation or moisture will not drain into the sensor. Where heavy condensation is present, a drip loop or an in-line filter should be installed to ensure long term operation.

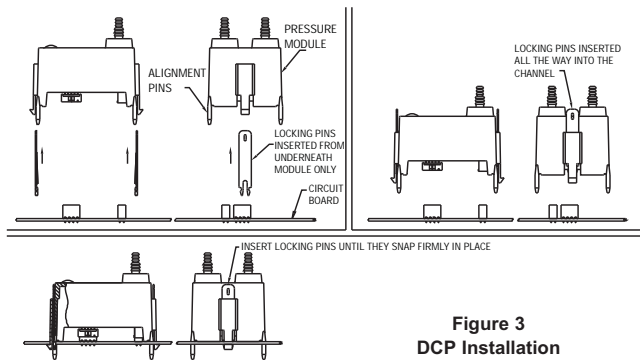

Figure 3
DCP Installation

1.3.2 Pressure Module Locking Pins

The DCP100A and DCP200A are supplied with locking pins to secure the module. In normal operation these are not required since the latching tabs are sufficient to secure the module even in a high vibration environment. However if the unit is to be shipped or used where severe mechanical shock could be encountered the locking pins ensure the module will not snap out of the board.

To install the locking pins, from underneath the module insert one locking pin behind each of the two latching tabs. Press these all the way into the channel. The ends of the tabs will extend through the slots at the top of these channels. Next insert the module in the board as described above, making sure it is properly aligned and snaps firmly in place. Press the exposed locking tabs down until the tab is seated behind the latch in the board. To remove the module, slide the locking tabs up using a small screw driver then remove the module as described above. See Figure 3.

1.3.3 Connecting DCP to Master Controller

The pressure module is attached to the Master Controller using integral connectors on both units. The insertion ports for the pressure module are located in the upper left quadrant of the DCT1000DC. The pressure module can be removed by compressing the retaining clips on each end of the module, then gently pulling the module out of the controller board.

When inserting the module, the following procedure should be adhered to insure proper installation:

- Examine the bottom of the pressure module and note the orientation of the connectors.
- Align the module so that these connectors match the connector receptacles on the controller board.
- Orient the module with the four alignment pins over their respective mounting holes.
- Gently press the module into the connectors and snap the retaining clips on either end of the module into their slots.
- Always install and service this device with the power off and a lockout installed if required. "Hot" plugging the pressure module into an operating system may damage the system or cause the calibration parameters to be erased.

When installing or removing the module make sure to orient the module straight with board. Installing or removing the module at any angle may break the alignment pins.



Caution: Do not force the module into the connectors. Forcing the insertion may damage the connectors. Properly aligned, the module should snap into place.

1.3.4 DCP Connections

When a pressure module is installed, the 4-20 mA process signal and the alarm relay contacts are available. The 4-20 mA circuit is isolated from ground and other signals. The alarm relay contacts are isolated, normally open contacts. Pressure connections may be made to the stepped hose barbs with either 1/8" (3.18 mm) or 3/16" (4.76 mm) I.D. tubing.

1.3.5 DCP Maintenance

The pressure module should require very little maintenance under normal operational conditions. However, periodic calibration may be desirable to assure accuracy of the readings. The module may be removed and returned to the factory for calibration.

1.4 Alarm Mode Switch Connection

The auto alarm reset is controlled by the alarm mode switch connection. To enable the auto alarm reset the alarm mode input must be connected to a common connection. A jumper may be used when auto alarm reset is always active. A switch may be used if there are times that the auto alarm reset must be disabled. The switch must be an isolated contact and wired such that no connection is made between either of the wires and ground. See Figure 2 Wiring Connections.

1.4.1 Alarm Reset Switch Connection

The alarm may be reset either by pressing the Alarm Reset button on the control panel or by an external switch connected between the alarm-reset terminal and one of the common terminals. The alarm reset will only operate if the pressure module is installed and the pressure has returned to a normal condition. See Figure 2 Wiring Connections.

1.4.2 Connecting the 4-20 mA Loop

The pressure module provides an isolated 4-20 mA output, which may be used to remotely monitor the differential pressure across the dust bags or cartridges. The connection is made on the master control module at the terminal block designated for this signal. The connection is a 2-wire configuration with the option of using either an external 15 to 35 VDC power source or using the internal 24 VDC source. See Figure 2 Wiring Connections.

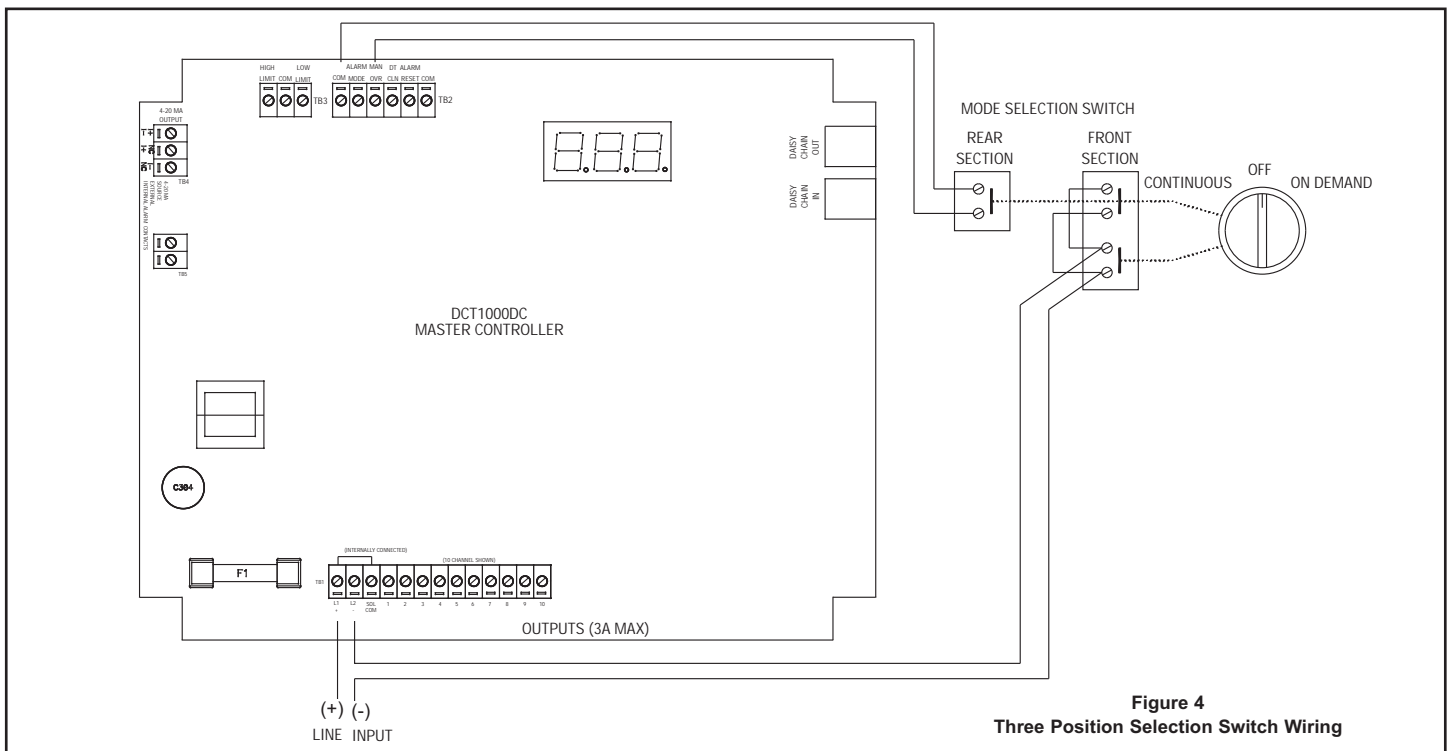

Figure 4
Three Position Selection Switch Wiring

1.5 Three Position Selection Switch Wiring

An optional mode selection switch is available with the weatherproof enclosure. With this switch the user may select either continuous cleaning, on-demand cleaning, or off. This switch is supplied factory wired as shown in Figure 4. The switch has a front and rear section. The front section, consisting of two independent contacts, controls the power to the board. These contacts must be wired in parallel as shown in the diagram. The rear section controls the manual override, which when closed will force the system into a continuous must be reconnected, follow the wiring diagram.



Caution: Do not interconnect the low voltage manual override leads with the power leads. This will destroy the control board as well as pose a serious shock hazard

2.0 Programming the DCT1000DC Master Controller

We've made it easy to navigate the DCT1000DC. Menu items can be accessed simply by pressing the "SELECT" button. The menu item that you are currently accessing is indicated by the illumination of an LED. To change menu items, all you have to do is push "UP" to increase a value or push "DOWN" to decrease a value. There are no keystrokes that you need to memorize, special combinations, or passwords that are required.

The master controller is equipped with an on board display and programming information center. The controller will power-up with the process indicator illuminated. If a pressure module is installed, the display will indicate the measured pressure in inches of water (w.c.); otherwise it will normally be blank.

2.1 • Last Output

The Last Output setup selects the last channel to be activated. When first selected, the display will flash the last output available in the system. With single board installations, this will be the number of channels installed, typically 6, 10 or 22. This value becomes more important when multiple modules are installed. The last output value flashed will be the sum of all channels available in the system.

After the last available channel indication has completed, the currently programmed last channel value is displayed. This value may be changed using the "UP" and "DOWN" buttons. The minimum value is one while the maximum value is the maximum number of installed channels, including all expansion modules.

The default value is the maximum number of channels. Pressing "SELECT" will change the setup mode to Time Off Setup.

2.2 • Time Off (Sec.)

Time off defines the period of time between solenoid activations when no channels are enabled. This may be set between one second and 255 seconds. The factory default is 10 seconds. The display will show the current time off setting when the time off setup mode is entered. The value may be changed using the Up and Down buttons. Pressing both "UP" and "DOWN" simultaneously and holding for approximately four seconds will restore the default value of 10.

2.3 • Time On (msec)

Time On Setup sets the solenoid on time. The display will indicate the currently programmed time on setting. This is measured in milliseconds. Using the "UP" and "DOWN" buttons, the value may be changed. The value may be set between 10 msec and 600 msec in 10 msec increments. Pressing the "UP" and "DOWN" buttons simultaneously for approximately four seconds will restore the factory default value of 100 msec. Pressing the "SELECT" button will advance the setup mode to the High Limit setup if the pressure module is installed. With no pressure module, it will step to Cycle Delay Setup.

2.4 • High Limit [Only available when DCP connected]

The High Limit Setup, available only with a pressure module installed, sets the pressure at which the cleaning cycle will begin. This value may be between zero and the pressure module full scale pressure. Normally, the High Limit should be above the Low Limit. If, however, the High Limit pressure is set below the Low Limit, the cleaning cycle will begin when the High Limit is exceeded and stop when the pressure falls below the High Limit. The Low Limit in this case will have no effect. Pressing "SELECT" will change the system to the Low Limit Setup mode.

2.5 • Low Limit [Only available when DCP installed]

The operation of the Low Limit, available only with a pressure module installed, is identical to the High Limit except this value sets the pressure where the cleaning cycle will end. The upper settable value is the calibration pressure of the pressure module and the lower limit is zero. Pressing "SELECT" will change the system to the High Alarm Setup mode.

2.6 • High Alarm [Only available when DCP installed]

The operation of the High Alarm Setup is identical to the High and Low Limit Setup and is only available when a pressure module is installed. The High Alarm default is 0. The upper settable value is the full scale pressure of the pressure module and the lower limit is zero. Pressing "SELECT" will change the system to the Low Alarm Setup mode.

2.7 • Low Alarm [Only available when DCP installed]

The operation of the Low Alarm Setup is identical to the High and Low Limit Setup. The Low Alarm default is 0. The upper settable value is the full scale pressure of the pressure module and the lower limit is zero. Pressing "SELECT" will change the system to the Cycle Delay Setup mode.

2.8 • Cycle Delay (min)

The cycle delay inserts a delay time between the end of the last channel and the beginning of the first channel. This may be set to between zero and 255 minutes. The factory default is zero. Setting the value to zero will disable the delay. Pressing "SELECT" will change the system to the Down Time Cycles Setup mode.

2.9 • Down Time Cycles (min)

The Down Time Cycles setup will select a value between zero and 255 minutes. The factory default is one minute. Selecting zero will disable the operation. When the down time cycles is activated by shorting the down time cycles input to the common terminal, (see figure 2) the system will enter a forced cleaning mode for the programmed duration. **Note:** The cycle delay, if one is programmed, will not be inserted in the timing cycle. Pressing "SELECT" will change the system to the Auto Alarm Reset Setup mode, if a pressure module is installed, or to Process when no pressure module is available.

2.10 • Auto Alarm Reset (sec) [Only available when DCP installed]

The Auto Alarm Reset Setup, available only when a pressure module is installed, allows the auto alarm reset time to be selected. This value may be set between zero and 255 seconds. The factory default value is five seconds. When the auto alarm reset is enabled by shorting the auto alarm reset terminal to a common terminal, (See Figure 1) the alarm will be reset after the pressure returns to the normal range and the timeout has expired. Pressing "SELECT" will change the system to Process mode.

3.0 Maintenance Support and Diagnostics

We have also included a number of features that will aid maintenance personnel in diagnosing problems or verifying that the system is operating.

3.1 Restoring Factory Defaults

The DCT1000DC has been programmed with factory default values that meet most industry operating conditions. In the event that you want to restore all of the parameters to the original factory default values:

(1) Return the master controller to the process mode.

(2) Press and hold both "UP" and "DOWN" buttons.

The display will indicate a 10-second countdown, at the end of which all parameters will be restored to factory defaults. Releasing the switches prior to the end of the count will stop the process and no modification will be made. Likewise, in each of the parameter setup modes, pressing and holding the "UP" and "DOWN" buttons simultaneously will reset the individual default value, leaving other settings unchanged.

3.2 Power Indicator

A power on LED indicator is provided at the center left edge of the board. This will be illuminated when the power supply is operating properly. If the power LED is not illuminated, the primary power may be off or there is a fault in the power circuit.

3.3 Active Channel Indicator

Located just above the solenoid terminations, you will find that each channel is provided with an LED that is illuminated when the triac switch is on. This allows a visual correlation between the channel being pulsed and the operation of the solenoid.

3.4 Comm Check Indicator

The comm check indicator can be found in the upper right hand corner of the slave and master controller board (just above the "out" terminal, a telephone style connector). This indicator is used for two purposes. First, on a master controller a brief flash once per second is produced to indicate that the system is operating. Second, this indicator is used to show when the communication check operation is performed on slave boards. The master controller will check each of the slave boards at a rate of about one inquiry per second, starting with the slave board connected directly to the master controller and ending with the last slave board in the chain. The master controller will flash its Comm Check LED for about 250 msec each time it makes a communication check. The external module selected for test will also flash its Comm Check LED for about the same time each time it is interrogated. Observing this test sequence will indicate that the communication between boards is operational. When a slave board powers up, the Comm Check LED will be illuminated continuously. It will be extinguished when the master controller has initialized its communication channel. This indicator then shows that a master controller is operating and that each slave board is responding properly on the daisy chain.

3.5 Error Codes

Error codes will be displayed on the three-digit display when certain faults occur. Most of these indicators are associated with the daisy chain communication, but certain error codes pertain to single board operation also. These codes are:

Display	Meaning	Action Required
Err 1	This is a "watchdog" reset that is enabled when the master controller isn't able to cycle through its operation.	Make sure all electrical connections are appropriately shielded so the master controller is not disrupted by noise.
Err 2	The pressure module has failed to respond to the request of the master controller.	The master controller will try to recover from the fault. If unsuccessful, replace the pressure module.
Err 3	Communication error in the daisy chain interface. This will only appear when the master controller is used in conjunction with a slave board.	Make sure the control cable used in the daisy chain interface is properly shielded from noise.
Err 4	The master controller has detected a change in module configuration or a fault in one of the modules.	Reinstall all modules in accordance with the instructions in the factory IOM.
Err 5	If the fault described in "Err 4" is not corrected, the master controller will reconfigure the modules that are responding properly and operate at a degraded condition.	Reinstall all modules. Contact factory if the problem persists.
Err 6	A message error affecting the software of the master controller or one of its modules.	Check the integrity of all connecting cables used to drive slave boards for additional solenoids. Also check the electrical grounding of the system installation.
Err 7	Indicates that one of the triac drivers are not functioning.	Return to factory for evaluation and repair.
Err 8	Internal Error.	Contact the factory.
Err 9	Unassigned message code.	Contact the factory.

4.0 Glossary of Terms

- **Run Mode:** The term used when the timer board is firing the solenoids.
- **Pressure Module:** The pressure measurement subsystem that includes the software and hardware for on-demand cleaning, alarms and signal retransmission of the process variable (i.e., the differential pressure across the dust bags).
- **Master Controller:** The primary timer board that contains all of the major features, connections for external inputs and power to drive the DCT1000DC Dust Collector Timer Controller system.
- **Power DC Guard:** A plastic shield that covers the output triacs and other line voltage circuitry.
- **Demand Cycle Mode:** A process in which the run mode is enabled through the on-board pressure module or an external switch.
- **Euro Connector:** A "caged" connection used to terminate solenoids, incoming power, or external switches on the DCT1000DC.
- **Continuous Cycle Mode:** A time based cycling mode dependent on solenoid time on/off settings and time set between complete cycles.
- **Manual Override:** Allows the user to override the DCT1000DC remotely or from the master controller panel through use of a switch or a wire jumper.
- **Slave Board:** A channel expander that is used in conjunction with the master controller to accommodate additional solenoids on larger dust collection systems. It can be recognized easily as it does not have the on-board display panel or the power supply present. A master controller may also be used as a slave board.

Still need help? Please feel free to contact one of our customer service representatives or visit us on the web at www.dwyer-inst.com. Thank you for choosing Dwyer Instruments, Inc.