

A8332-8F2D Modbus Flex IO Module
Obvius, LLC

Installation and Operation Manual

Date Jun 21, 2010

Copyright Information

Copyright © 2008 - 2010 by Obvius

Obvius and **AcquiSuite** are trademarks of Obvius Holdings LLC

Other brand and product names are trademarks or registered trademarks of their respective holders.

U.S. Government Restricted Rights: Use, duplication or disclosure by the Government is subject to restrictions set fourth in subparagraph (a) through (d) of the Commercial Computer Restricted Rights clause at FAR 52.227-19 when applicable, or subparagraph (c) (1) (ii) of the Rights in Technical Data and Computer Software clause at DFARS 252.227-7013, and in similar clauses in the NASA FAR Supplement.

Limited Warranty

OBVIUS IS PROVIDING THIS WARRANTY IN LIEU OF ALL OTHER EXPRESS OR IMPLIED WARRANTIES, INCLUDING ANY WARRANTY OF MERCHANTABILITY OR FITNESS FOR A PARTICULAR PURPOSE. THIS WARRANTY IS BUYER'S EXCLUSIVE REMEDY FOR ALL CLAIMS AGAINST OBVIUS. OBVIUS SHALL NOT BE LIABLE FOR ANY CONSEQUENTIAL OR INCIDENTAL DAMAGES. OBVIUS'S TOTAL LIABILITY FOR ALL CLAIMS SHALL BE LIMITED TO THE PRICE PAID FOR ITS PRODUCT.

Obvius promises buyer that any standard product manufactured by Obvius shall be free from all material defects in design, material, or manufacturing for a period of 2 years from the manufacture date; provided, however, that the warranty shall not extend to ordinary wear and tear or to normally replaceable components (e.g., batteries). During the warranty period, Obvius may repair or replace (in its sole discretion) any product suffering from a warranty defect and returned freight prepaid by buyer, with no charge to buyer for any warranty repair or replacement. The warranty shall remain in full force and effect for such 2 year period, provided that the product: (1) was installed, operated, and maintained properly; (2) has not been abused or misused; (3) has not been repaired, altered, or modified outside of Obvius's authorized facilities; (4) has not been sold subject to other warranty terms specified at the time of sale; and (5) is still owned by the original purchaser. This warranty provides specific legal rights that may be varied by state law. Obvius's products are not designed for life or safety applications.

Product Application Limitation

Obvius products are not intended for use in critical applications such as nuclear facilities, human implantable devices or life support. Obvius is not liable, in whole or in part, for any claims or damages arising from such uses.

Obvius strongly believes in continuous improvement, therefore we must reserve the right to change specifications and product offerings without notice. Where possible, we will substitute products with equivalent functionality when necessary.

NOTICE

- This product is not intended for life safety applications.
- Do not install this product in hazardous or classified locations.
- The installer is responsible for conformance to all applicable codes.

FCC Part 15 Information

Note: This equipment has been tested by the manufacturer and found to comply with the limits of a class A digital device, pursuant to part 15 of the FCC rules. These limits are designed to provide reasonable protection against interference when the equipment is operated in a commercial environment. This equipment generates, uses, and can radiate radio frequency energy and, if not installed and used in accordance with the instruction manual, may cause harmful interference to radio communications. Operation of this equipment in a residential area is likely to cause harmful interference in which case the user will be required to correct the interference at his own expense. Modifications of this product without the express authorization of Obvius nullify this statement.

Table of Contents

Markings and Symbols.....	3
Hardware Overview.....	4
Features and Specifications.....	4
Installation Checklist.....	5
Configuration Software Required.....	5
Electrical Connections.....	6
Hardware Installation.....	6
Dipswitch Configuration.....	8
Operation.....	8
Troubleshooting.....	9
Pulse count input troubleshooting.....	9
Analog 4-20mA input troubleshooting.....	9
Analog 0-10V input troubleshooting.....	9
Modbus registers.....	10
Functions.....	10
Input Modes:	10
Mode Register value:.....	10
Pulse Mode:.....	10
Status Mode:.....	11
Voltage Mode, Current Mode, Resistance Mode:	11
Modbus Register Listing.....	12
Register Functions.....	14
Mechanical Drawings.....	15

Markings and Symbols:

WARNING: A potential risk exists if the operating instructions are not followed



General Warning Symbol: This symbol indicates the need to consult the operating instructions provided with the product.



This symbol indicates the presence of electric shock hazards.



This symbol indicates: Do not apply to or remove from hazardous live conductors.

== Direct Current symbol.

Hardware Overview

The A8332-8F2D is designed to read a variety of industry standard analog and pulse sensor devices and communicate the data values back to a Modbus master system using RS485. Applications include data acquisition systems reading gas/water/electric meters or analog sensors such as temperature, humidity, pressure, and flow.

Features and Specifications

Processor	Arm7, field upgradeable firmware.
LED	8 input status LEDs (red), 2 Modbus TX/RX (yellow), 1 power/alive status. (green)
Protocols	Modbus/RTU
Power Supply	24VDC, 200mA ³ , Required (not included) The unit is to be sourced by a Class 2 power supply with the following output: 24Vdc, 200 mA minimum but not to exceed 8A
Serial Port ¹	RS-485 two wire, 19200 or 9600 baud, 8N1
Inputs ¹	8 flex-io inputs with multiple modes: voltage, current, resistance, pulse and status.
Voltage mode:	0-10vdc (min/max/average/instantaneous data) accuracy: +/- 0.25% of full scale at 20°C
Current mode:	4-20mA (min/max/average/instantaneous data) accuracy: +/- 0.25% of full scale at 20°C
Resistance mode:	100 ohms to 100k. Accuracy: 100Ω – 1kΩ +/- 1% of 1kΩ at 20°C 1kΩ – 10kΩ +/- 1% of 10kΩ at 20°C 10kΩ – 47.5kΩ +/- 1% of 47.5kΩ at 20°C 47.5kΩ – 100kΩ +/- 1% of 100kΩ at 20°C 100kΩ – 10MΩ accuracy unrated.
Pulse mode:	intended for use with dry contact outputs. (consumption/rate/runtime/status) Standard and KYZ modes for form A and C relay outputs Input terminal supplies 5V at 5mA sense voltage to detect contact closures. Maximum rate: 10hz, minimum pulse width 50ms. Adjustable contact closure threshold: 100Ω to 5kΩ, broken wire sense above 10kΩ optional. Pulse count and runtime values are stored in non-volatile memory.
Outputs ¹ :	2 optically isolated outputs type: opto-fet, dry contacts. rating: 30vdc, 150mA max.
Isolation ² :	Pulse outputs are isolated to 1500VDC from main board. RS485 port is isolated to 1500VDC from the main board.
Environmental	Power input, RS232, and analog/pulse inputs and are non-isolated. Pollution Degree 2, Altitude up to 2000M. For indoor and outdoor use when used in an appropriate enclosure. The A8332-8F2D must be mounted inside a NEMA rated electrical enclosure for safety and isolation requirements.
Safety	North America: Indoor, temperature -30° - +70°C, 0 - 95% humidity, non-condensing. ⁴ UL61010 Recognized ⁴
EMC	File: E320540 (Model A8332-8F2D) FCC CFR 47 Part 15, Class A EN 61000, EN 61326
Size	4.13" x 3.39" x 1.18" (105mm x 86mm x 30mm)
Mass	3.7 oz (105 g)

¹ Inputs are intended for low voltage Class 2 outputs.

² If the product is used in a manner not specified by the manufacturer, the protection provided by the equipment may be impaired.

³ Power consumption listed does not include power consumed by attached sensor devices. The combined current draw requirements of all 8 input sensors should not exceed 200mA.

⁴ Devices manufactured before Feb 1, 2010 are rated to 0 ~ 50c, and are not UL recognized.

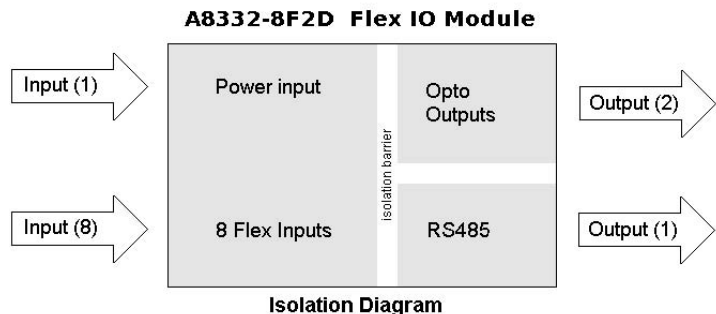

Installation Checklist

The following components are required for a complete A8332-8F2D I/O module installation:

- A8332-8F2D I/O module
- Screwdriver for terminals: 2.4mm slot/straight or equivalent.
- Obvius Configuration Console software.
- A computer with an RS232 or RS485 port and a serial cable, or a USB to serial adapter.
- Modbus/RTU master device such as an AcquiSuite™ A8812 server
- Pulse or analog output device
- Power supply: 24VDC
- Wire. Typically 18 to 24 gauge ³ for pulse or analog device connection.
- 2 wire, twisted pair with shield for Modbus/RS485 connection. (Belden 1120A or equivalent)³
- Optional: Termination resistor (120 ohm) for long RS485 runs over 200ft.

³ Insulation connected to pulse meters inside high voltage panels should have an insulation rating in excess of the service voltage. Consult a licensed electrician and local building codes for further requirements that may apply.

Configuration Software Required:

The A8332-8F2D requires configuration before it may be used. There are three primary ways to achieve this.

1) **Obvius Configuration Console:** The Obvius Configuration Console (OCC) is a software application designed to assist in the setup and commissioning of Obvius hardware products. The OCC software is available for free download at <http://obvius.com>. This manual makes a number of references to the OCC software. Installers are well advised to obtain a copy of the OCC software prior to installing the A8332-8F2D on the jobsite.

2) **AcquiSuite:** Installers can use the Obvius AcquiSuite configuration web page to set up features in the A8332-8F2D.

3) **3rd party software or hardware/plc.** If neither the OCC software or AcquiSuite are available, all features in the A8332-8F2D may be configured by writing modbus register values to the device. Installers may use a software tool such as ModScan32 or SimplyModbus to write to the registers. Also, many hardware data loggers or PLC systems can write to Modbus registers as well. Complete modbus register information is available in this document in the “Modbus Register setup” section for installers who wish to use 3rd party software or hardware to set up the A8332-8F2D.

Electrical Connections

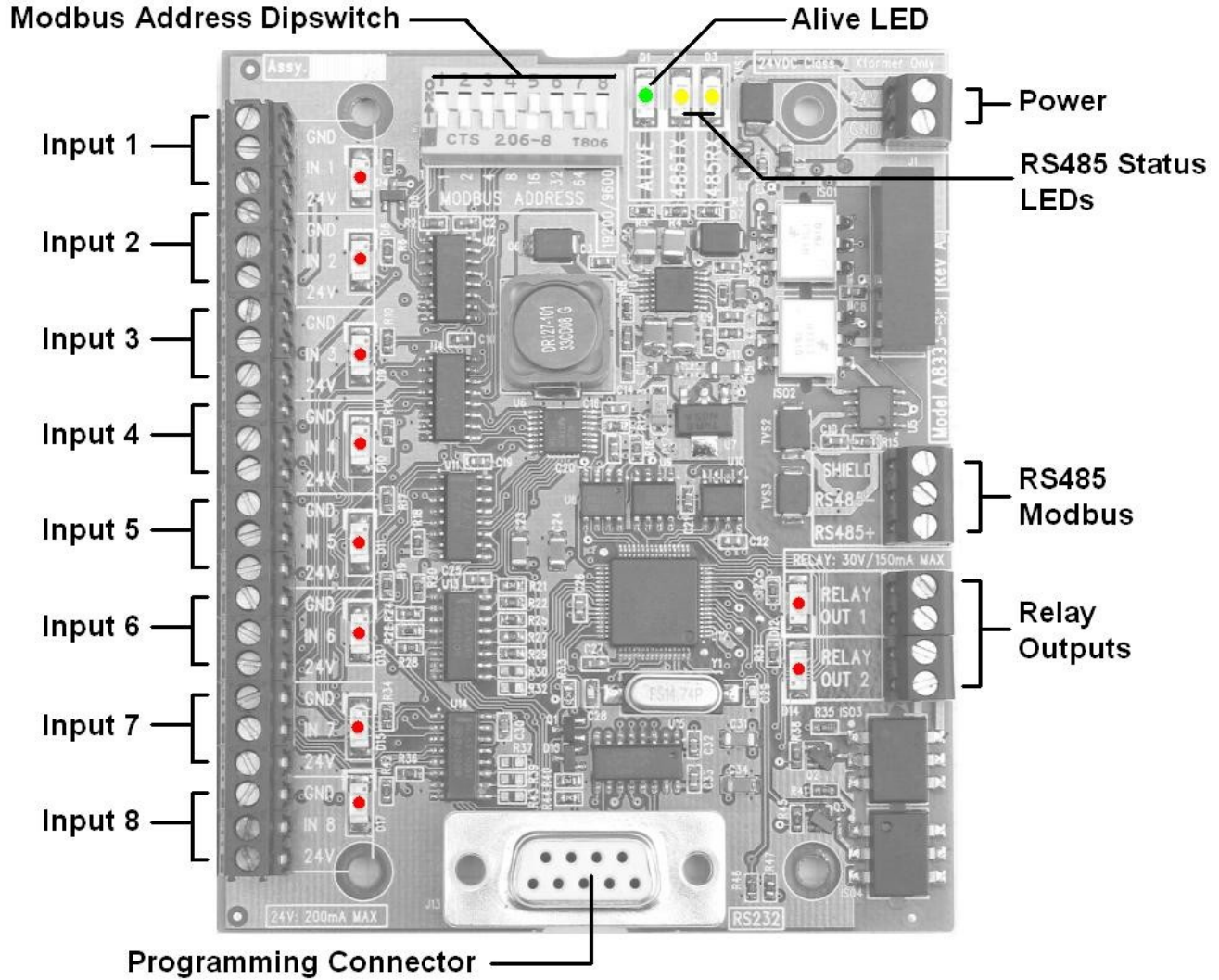

Hardware Installation

- 1) Mount the A8332-8F2D on a DIN-Rail or appropriate mounting enclosure.
- 2) Attach the power supply to the input terminals on the A8332-8F2D module.
- 3) Attach the RS485 +, - and shield wires to the A8332-8F2D module. Attach the other end of the RS485 line to the Modbus master device, such as an AcquiSuite. Be careful to observe polarity on both ends of the RS485 connection. RS485 wiring runs should be limited to 4000 ft.
- 4) Set the Modbus address dipswitches and baud rate dipswitch. For more information on the switch options, see the section below for configuration.
- 5) Turn on the power supply. Confirm the green Alive LED starts blinking about once per second.
- 6) Check the RS485 yellow LEDs.

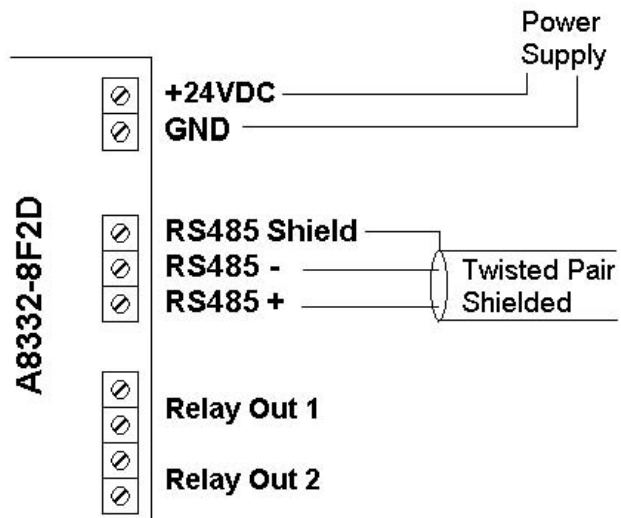

- If the A8332-8F2D receives any Modbus traffic on the RS485 port, the yellow RX led should blink.
- If the A8332-8F2D receives a Modbus query that is addressed to it specifically, the yellow TX LED should blink and it will respond to the query.

If you are using an AcquiSuite Data Acquisition Server, the A8332-8F2D should appear in the Modbus device list after about 2 minutes at the Modbus address set in step 4 above. Click on the device, and select “Configure” to give the A8332-8F2D a logical name. This will allow the AcquiSuite to begin logging data for the device. If you are using the Obvius Configuration Console, enter the Modbus address from step 4 above in the scan range field and click scan. The A8332-8F2D should appear in the device list with that Modbus address.

- 7) With the power disconnected, attach the pulse or analog input lines to the input terminals. Each input has a GND , Input#, and +24V terminal.

The A8332-8F2D provides 3-5 volts on the Input# terminal for sensing in pulse or contact closure mode. The remote pulse output device must not supply voltage to the terminals.

Wiring runs to input terminals should be kept as short as possible. Wiring runs longer than 200 ft should be avoided. Wiring should avoid proximity to sources of electrical noise such as running in parallel to electrical cable, and VFD systems.

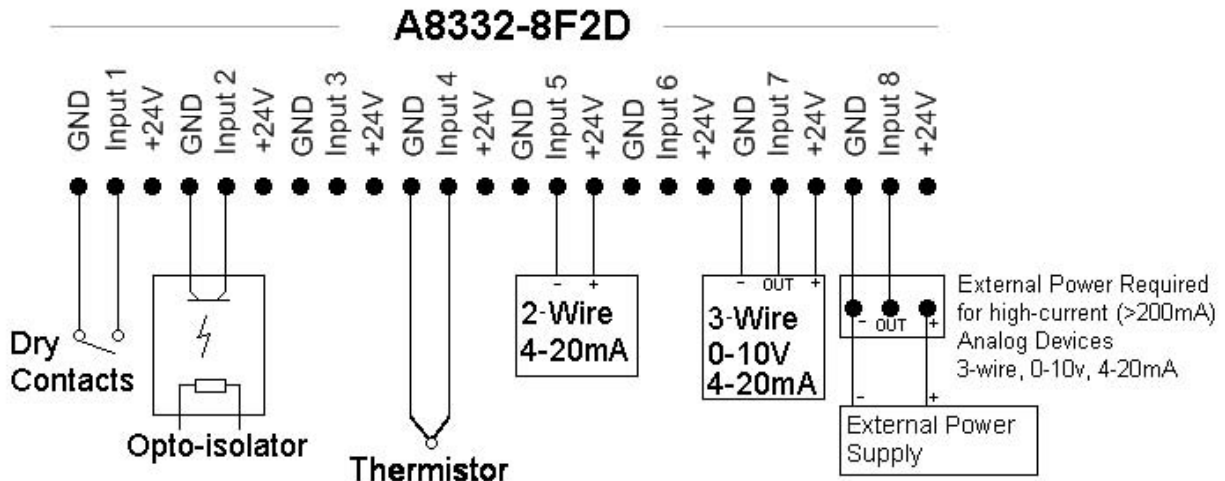

- 8) Power up the A8332-8F2D. The Alive LED should blink once per second. Use the AcquiSuite or the Obvius Config Console software or AcquiSuite to confirm the operation of each input.



WARNING: After wiring the A8332-8F2D, remove all scraps of wire or foil shield from the electrical panel. This could be dangerous if wire scraps come into contact with high voltage wires.

Dipswitch Configuration

Modbus Address: Before the A8332-8F2D can be used, you must set the Modbus address of the A8332-8F2D. This address must be unique among all Modbus devices in the system. The A8332-8F2D supports address 1 through 127.

Select an address, and set the dipswitches to match.

The sum of the value of the switches is the address. In the example to the right, address 52 is set by placing switch 4, 16 and 32 to the on position.

Note: $4 + 16 + 32 = 52$

Baud Rate: This option sets the serial port speed for the RS485 port. Set this option to “off” for 19200. Set the switch to “on” for 9600 baud.

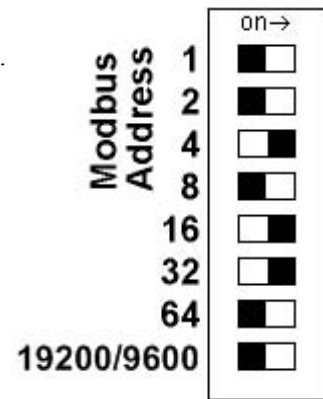

Operation

The device should power up and be ready in a few seconds. The LEDs should blink in the following manner.

- The green "Alive" LED should start to blink approximately once per second.
- The yellow RS485 TX and RX LEDs will blink for local Modbus activity.
- For each input, you MUST configure the input mode register. [40065 – 40072]. The mode register sets up the input for 4-20mA, 0-10V, pulse, or resistance type sensors. The default mode is “unconfigured”. The following methods can be used to configure each input. (you should choose only one method below)
 - Use the AcquiSuite device configuration page, select configure point. Pick the appropriate mode from the dropdown list. Also, you will need to configure each pulse input with a Name, Engineering Unit, and Multiplier.
 - Use the Obvius Config Console software available at obvius.com. Select the A8332-8F2D from the list, and choose the input mode from the dropdown list. Be sure to click the “Save” button at the bottom of the page.
 - If neither the AcquiSuite or the OCC software are available, you can use any modbus register writing software or hardware, such as ModScan32, or a PLC. Select the input mode register and write the appropriate value to that register. For a complete list of registers, and allowed mode values, please review the Modbus Register Listing section towards the end of this document.
- After configuring the input mode, the red input status LEDs will show information for each input depending on the configured mode of the input. Input status LEDs are adjacent to the corresponding input screw terminals.
 - For inputs configured for pulse, pulse-kyz, and status, the LED will turn on when the contact is closed.
 - For 4-20mA, 0-10V modes, the LED will show off-scale-high by blinking fast (2x second)
 - For 4-20mA and Resistance mode, the LED will show a broken wire alarm with a blink-blink-off pattern.
 - For unconfigured inputs, the LED will be off.

Troubleshooting

Pulse count input troubleshooting:

Verify the pulse output meter is connected to the GND and IN# terminals of the A8332-8F2D. (not the +24V terminal)

Use the OCC software or AcquiSuite configuration page. Verify the specific input mode is set to Pulse, Pulse-kyz, or Status.

Check the input LED for the specific input that is not working. The LED should blink when the pulse meter closes the contact output. If the LED is not blinking, try bridging the input terminals with a short piece of wire to confirm the LED comes on. Note: if the input LED lights up when you bridge the input terminals, the problem is likely with the meter, and/or the wiring to the meter.

If the LED is always on, you may have a short in the wires leading to the pulse output meter. Try removing the wires from the A8332-8F2D input to confirm the LED turns off. If so, repeat the test with the wires attached at the A8332-8F2D, and disconnected at the pulse output meter.

Try bridging the terminals at the other end of the pulse wiring run. This will confirm there are no breaks in the wire.

Verify the pulse output device is operating.

Disconnect the A8332-8F2D input and use a hand held digital meter and measure resistance of the pulse output device. Verify that the pulse output device is operational and the contact closure reads less than 1000 ohms when closed. For high resistance pulse devices such as intrinsic barriers, the “contact closure threshold” register may need to be configured to a larger value. The default is 1k however up to 2.5k is allowed. If using the OCC software or the AcquiSuite data acquisition server, use the advanced configuration page of the A8332-8F2D in the Modbus/device list to set this option.

Analog 4-20mA input troubleshooting:

Verify the analog output sensor is connected to the proper terminals. For a 2 wire 4-20mA sensor, this is typically the +24 and IN# terminals of the A8332-8F2D.

Use the OCC software or AcquiSuite configuration page. Verify the specific input mode is set to 4-20mA mode.

Check the input LED for the specific input that is not working. The LED should be off for normal operation. If the sensor reads below 4mA, the LED will show a blink-blink-off pattern. If the sensor is reading above 20mA, the LED will blink in a fast (2Hz) pattern.

Use the OCC software to view the mA output reading for the channel.

Use a hand-held meter. Select the DC mA reading mode of the meter and wire the meter in series with the sensor output, and the A8332-8F2D input terminal. Typically, the Red/+ meter probe connects to the sensor output wire, and the Black/- meter probe connects to the IN# terminal of the A8332-8F2D. Verify the mA reading on your meter matches the OCC software reading.

Analog 0-10V input troubleshooting:

Verify the analog output sensor is connected to the proper terminals. For a self-powered 2 wire 0-10V sensor, this is typically the GND and IN# terminals of the A8332-8F2D. For a 3 wire device that uses power supplied by the A8332-8F2D, all three input wires (GND, IN# and +24V) will be used.

Use the OCC software or AcquiSuite configuration page. Verify the specific input mode is set to 0-10V mode.

Check the input LED for the specific input that is not working. The LED should be off for normal operation. If the sensor is reading above 10V, the LED will blink in a fast (2Hz) pattern.

Use the OCC software to view the voltage output reading for the channel.

Use a hand-held meter. Select the DC Volts reading mode of the meter and wire the meter in parallel with the sensor output; this will use the Red/+ meter probe on the IN# terminal and the Black/- meter probe on the GND terminal. Verify the voltage reading on your meter matches the OCC software reading.

Modbus registers

Functions

The A8332-8F2D responds to the following Modbus/RTU functions:

function 0x11 Report slave id.
function 0x03 read holding registers (multiple)
function 0x06 preset single register

All Modbus registers are read-only unless otherwise noted. Registers listed as “NV” are options that are stored in non-volatile memory and will be preserved when power is removed from the device.

Input Modes:

Each of the 8 inputs has several different modes (4-20mA, 0-10v, pulse, etc) The following sections list the purpose of each of the Modbus registers depending on the selected mode.

Mode Register value:

The value of the mode register (40065 - 40072) controls the mode of the input (volts, pulse, etc). Users may write to the mode register, and it will be stored in non-volatile memory. Note however that the preferred operation is to use the OCC tool or the A8812 AcquiSuite web page interface to configure the input mode.

- 0 = unconfigured (return 0xFFFF for all registers associated with this input)
- 1 = reserved.
- 2 = Analog current mode, 4-20mA range.
- 3 = voltage mode, 0-10v range.
- 4 = resistance mode, as ohms measured. 0-10Mohm range.
- 5 = contact closure mode, reports closure count and dutycycle.
- 6 = pulse counter input. (standard) counts contact closures only.
- 7 = pulse counter input. (KYZ mode) counts closure and open.

Pulse Mode:

count: the number of pulses counted on the input port. In standard mode, the pulse is counted on the closure of the contact. If the KYZ option is enabled, both the closure and opening of the pulse are counted. The maximum pulse rate to be able to count is 10 Hz. Expect pulse width to be minimum of 20ms. The pulse count starts at zero (factory default) and always increments as pulses are counted. Rollover at 2^{32} (approx 4.3 billion). Count is stored in non-volatile memory. The pulse count can not be reset to zero.

rate-inst: This register reports the instantaneous rate of pulses received on the input, calculated based on the time the last N pulses were received. For example, if the pulse rate is 2Hz, and N is 5, then 5 pulses will be received in 10 seconds, and the rate-inst value will return 10. N is user selectable from 2 to 20. Note: as the value of rate-inst increases, the pulse rate it represents decreases. thus, a value of 20(seconds) represents a pulse rate that is 1/2 of a 10s value. If the pulse rate is very fast such that $rate-inst < N$ the value of rate-inst will be unusable due to the granularity of the measurement. This should be handled as off-scale-high by the Modbus master system. To properly handle this situation, reconfigure the pulse output meter with a slower pulse rate using a larger multiplier. The rate-inst register will report 65535 when off-scale-low. When reading large values from rate-inst, it is advisable to handle numbers as off-scale-low when the number of seconds exceeds the data logging interval.

rate-min: The minimum rate value as measured in rate-inst. Note: the minimum rate is actually the largest count of seconds seen in rate-inst.

rate-max: The maximum rate value as measured in rate-inst. Note: the maximum rate is actually the smallest count of seconds seen in rate-inst.

* **clear min/max** (register 41021): The Modbus registers for rate-inst, rate-min and rate-max may be cleared by writing to a Modbus register. It is assumed that these three fields will be cleared at the beginning of each new logging period by the Modbus master device. In pulse mode, clearing the inst register does not clear the pulse count history. The fields for inst/min/max will be valid after only one pulse value is received.

* **average rate:** (not an A8332-8F2D datapoint) The AcquiSuite will compute an average rate for the pulse count input. The calculation will be performed at the end of each logging cycle by subtracting the count at the start and end of the interval and dividing by the interval length. (DV/DT). This will provide the average rate over the log interval. If the unit of measure is power related, (kwh, kvarh, kvah, etc) the average rate will be called "demand" as it is the effective block demand value for the input. Because the rate value is not a Modbus register, Modbus master devices must use the "count" register and compute the average rate value.

Status Mode:

count: the number of pulses counted on the input port. In standard mode, the pulse is counted on the closure of the contact. If the KYZ option is enabled, both the closure and opening of the pulse are counted. The maximum pulse rate to be able to count is 10 Hz. Expect pulse width to be minimum of 20ms.

on-time: the cumulative number of seconds the contacts have been closed. The pulse count starts at zero (factory default) and always increments as pulses are counted. Rollover at 2^{32} (over 130 years). Count is stored in nv memory. This value has 1 second granularity, rounding is performed by sampling the input once per second and accumulating 1 second if the contact is closed at that time. For practical applications, the pulse width should be a minimum of 1 second.

dutycycle: The ratio of of time the contact is closed vs open. For example, if the contact is closed for 10 seconds and open for 30, the dutycycle register will report 25%. The register value returned must be divided by 1000 to convert it to a percentage with three decimal places.

status: returns 1 if the contact is presently closed, 0 if the contact is presently open.

* **clear min/max** (register 41021): the only value cleared in status mode is the dutycycle field. The data logger will clear this field at the beginning of each log period. The dutycycle register will be used to calculate the dutycycle for one log period only.

Voltage Mode, Current Mode, Resistance Mode:

(all 3 modes are the same unless otherwise noted)

instantaneous: The instantaneous reading will report the present status of the input, represented in ohms, mA, or volts. The value uses a short term average of the last 16 a/d converter readings to compute the value of this register. In voltage and current mode, the instantaneous value is calculated several times per second. In resistance mode, the value is calculated at least every two seconds. 0xFFFFFFFF will report an off-scale-high condition, or any other invalid data.

average: This register reports the longer term average of the input. Each time a short term average is calculated with all-new samples, the value is added to the cumulative average. This value should be reset using the clear min/max register at least once per hour. If not cleared, it will eventually start a moving average after memory storage is exceeded. The AcquiSuite will clear this register at the start of each data logging period.

min: the minimum value seen in the instantaneous register.

max: the maximum value seen in the instantaneous register.

* **Multipliers:** The register value for inst, average, min, and max must be divided by 1000 to convert the number to mA and Volts. Volts mode reports 0 to 10.000V. Current mode reports 0 to 20.000mA. In resistor mode value is reported in ohms and no division is required. Note: in current mode, the broken-wire register 40074 is set when the input goes below 4mA, however the current value reading will still be shown in the data register. Modbus master systems should typically discard readings below 4mA as broken-wire/invalid when reading a 4-20mA sensor.

* **clear min/max** (register 41021): This register clears the values for average, min, and max. The historical accumulation of samples for the average field will be cleared, and average, min, max will be set to the present instantaneous value after the next instantaneous value is recalculated.

Modbus Register Listing

Data points:

offset	point	type	desc	modes-->	Pulse	Status	Ohms, mA, volts
0	40001	UINT32	input 1	value MSW	(count/NV,	count/NV,	inst, inst, inst)
1	40002	UINT32	input 1	value LSW			
2	40003	UINT32	input 2	value MSW	(count/NV,	count/NV,	inst, inst, inst)
3	40004	UINT32	input 2	value LSW			
4	40005	UINT32	input 3	value MSW	(count/NV,	count/NV,	inst, inst, inst)
5	40006	UINT32	input 3	value LSW			
6	40007	UINT32	input 4	value MSW	(count/NV,	count/NV,	inst, inst, inst)
7	40008	UINT32	input 4	value LSW			
8	40009	UINT32	input 5	value MSW	(count/NV,	count/NV,	inst, inst, inst)
9	40010	UINT32	input 5	value LSW			
10	40011	UINT32	input 6	value MSW	(count/NV,	count/NV,	inst, inst, inst)
11	40012	UINT32	input 6	value LSW			
12	40013	UINT32	input 7	value MSW	(count/NV,	count/NV,	inst, inst, inst)
13	40014	UINT32	input 7	value LSW			
14	40015	UINT32	input 8	value MSW	(count/NV,	count/NV,	inst, inst, inst)
15	40016	UINT32	input 8	value LSW			
				modes-->	Pulse	Status	Ohms, mA, volts
16	40017	UINT32	input 1	ave MSW	(rate-inst,	on-time/NV,	ave, ave, ave)
17	40018	UINT32	input 1	ave LSW			
18	40019	UINT32	input 2	ave MSW	(rate-inst,	on-time/NV,	ave, ave, ave)
19	40020	UINT32	input 2	ave LSW			
20	40021	UINT32	input 3	ave MSW	(rate-inst,	on-time/NV,	ave, ave, ave)
21	40022	UINT32	input 3	ave LSW			
22	40023	UINT32	input 4	ave MSW	(rate-inst,	on-time/NV,	ave, ave, ave)
23	40024	UINT32	input 4	ave LSW			
24	40025	UINT32	input 5	ave MSW	(rate-inst,	on-time/NV,	ave, ave, ave)
25	40026	UINT32	input 5	ave LSW			
26	40027	UINT32	input 6	ave MSW	(rate-inst,	on-time/NV,	ave, ave, ave)
27	40028	UINT32	input 6	ave LSW			
28	40029	UINT32	input 7	ave MSW	(rate-inst,	on-time/NV,	ave, ave, ave)
29	40030	UINT32	input 7	ave LSW			
30	40031	UINT32	input 8	ave MSW	(rate-inst,	on-time/NV,	ave, ave, ave)
31	40032	UINT32	input 8	ave LSW			
				modes-->	Pulse	Status	Ohms, mA, volts
32	40033	UINT32	input 1	min MSW	(rate-min,	dutycycle,	min, min, min)
33	40034	UINT32	input 1	min LSW			
34	40035	UINT32	input 2	min MSW	(rate-min,	dutycycle,	min, min, min)
35	40036	UINT32	input 2	min LSW			
36	40037	UINT32	input 3	min MSW	(rate-min,	dutycycle,	min, min, min)
37	40038	UINT32	input 3	min LSW			
38	40039	UINT32	input 4	min MSW	(rate-min,	dutycycle,	min, min, min)
39	40040	UINT32	input 4	min LSW			
40	40041	UINT32	input 5	min MSW	(rate-min,	dutycycle,	min, min, min)
41	40042	UINT32	input 5	min LSW			
42	40043	UINT32	input 6	min MSW	(rate-min,	dutycycle,	min, min, min)
43	40044	UINT32	input 6	min LSW			
44	40045	UINT32	input 7	min MSW	(rate-min,	dutycycle,	min, min, min)
45	40046	UINT32	input 7	min LSW			
46	40047	UINT32	input 8	min MSW	(rate-min,	dutycycle,	min, min, min)
47	40048	UINT32	input 8	min LSW			
				modes-->	Pulse	Status	Ohms, mA, volts
48	40049	UINT32	input 1	max MSW	(rate-max,	status	max, max, max)
49	40050	UINT32	input 1	max LSW			
50	40051	UINT32	input 2	max MSW	(rate-max,	status	max, max, max)
51	40052	UINT32	input 2	max LSW			
52	40053	UINT32	input 3	max MSW	(rate-max,	status	max, max, max)
53	40054	UINT32	input 3	max LSW			
54	40055	UINT32	input 4	max MSW	(rate-max,	status	max, max, max)
55	40056	UINT32	input 4	max LSW			
56	40057	UINT32	input 5	max MSW	(rate-max,	status	max, max, max)
57	40058	UINT32	input 5	max LSW			
58	40059	UINT32	input 6	max MSW	(rate-max,	status	max, max, max)

```

59      40060    UINT32  input 6 max LSW
60      40061    UINT32  input 7 max MSW      (rate-max, status      max, max, max)
61      40062    UINT32  input 7 max LSW
62      40063    UINT32  input 8 max MSW      (rate-max, status      max, max, max)
63      40064    UINT32  input 8 max LSW

                                Mode setting options.  see above for value details.
64      40065    UINT16  input 1 mode (NV/r/w)
65      40066    UINT16  input 2 mode (NV/r/w)
66      40067    UINT16  input 3 mode (NV/r/w)
67      40068    UINT16  input 4 mode (NV/r/w)
68      40069    UINT16  input 5 mode (NV/r/w)
69      40070    UINT16  input 6 mode (NV/r/w)
70      40071    UINT16  input 7 mode (NV/r/w)
71      40072    UINT16  input 8 mode (NV/r/w)

72      40073    UINT16  input status bitmap. (pulse/status modes only)
73      40074    UINT16  input broken wire alarm bitmap. (resistance, current modes only)
                                Restive mode: bit set when resistance is off-scale-high.
                                4-20mA mode: bit is set when current is below 4mA.

74      40075    UINT16  relay output 1 (r/w) 0=open, 1=closed,
                                defaults to open on power-up.
                                r/w allowed when register 41030 = 0.
75      40076    UINT16  relay output 2 (r/w) 0=open, 1=closed

--- system settings and information ---

999     41000    UINT16  contact closure threshold (NV/r/w) in ohms, default 1000 = 1kohm.
                                (minimum value 100 ohms, maximum value 5000 ohms)
1000    41001    UINT16  contact open wire threshold (NV/r/w) in ohms,
                                default/unused = 0xFFFF, limit 100 to 10,000 ohms.
1001    41002    UINT16  number of pulses for inst rate (NV/r/w) default 5.
                                limit 2 to 20.

1002    41003    UINT16  serial number bytes 1,2
1003    41004    UINT16  serial number bytes 3,4
1004    41005    UINT16  serial number bytes 5,6

1005    41006    UINT16  firmware version (major)
1006    41007    UINT16  firmware version (minor)

1007    41008    UINT32  Reserved
1008    41009    UINT32  Reserved
1009    41010    INT16   Reserved
1010    41011    INT16   Reserved

1011    41012    UINT32  uptime MSW  number of seconds since IO module booted.
1012    41013    UINT32  uptime LSW

1013    41014    UINT16  hardware version (major) for example: 8332
1014    41015    UINT16  hardware version (minor) MSB = pcb rev, LSB = part rev.
                                value 1=Rev_A, 2=Rev_B, etc.

1015    41016    UINT32  hardware Date of Manufacture (MSW)
1016    41017    UINT32  hardware Date of Manufacture (LSW)
                                time, UTC, unix epoch, seconds past 1970.

1017    41018    UINT16  RS485 Stats: Good RX (all packets received)
1018    41019    UINT16  RS485 Stats: Total TX
1019    41020    UINT16  RS485 Stats: TX failed

1020    41021    UINT16  clear min/max/ave (r/w) read returns 0, write any value to clear
                                min/max/ave for all channels.

1021    41022    UINT8   reserved
1022    41023    UINT8   reserved
1023    41024    UINT8   reserved

1024    41025    UINT8   reason for reboot. 0x01=POR, 0x02=EXTR 0x04=WDTR 0x08=BODR,
                                0x8000=WDTOF

```

1025	41026	UINT16	power supply voltage monitor. scale: x100, volts
1026	41027	INT16	pcb temperature monitor. scale: x100, degrees F.
1027	41028	UINT16	5V internal power supply voltage monitor. scale: x100, volts
1028	41029	UINT16	RS485 baud rate. 2=9600, 3=19200.
1029	41030	UINT16	relay output 1 mode. (R/W, NV) 0>manual, 1=follow pulse input #1. Note: input must be in pulse or status mode.
1030	41031	UINT16	relay output 2 mode. (R/W, NV) 0>manual, 1=follow pulse input #2. Note: input must be in pulse or status mode.

Modbus function 0x11 Slave ID response will report the following:

"Obvius, A8332-8F2D, IO Module, 8-Flex, 2-DO", id=48

Register Functions

Pulse Count: The pulse count is stored as an unsigned 32bit integer. This allows for 2³² pulses (4.2billion) to be counted before rollover. On Modbus systems that do not allow you to read 32bit values, you can calculate the pulse count as follows:

$$\text{count} = (\text{MSW} * 65536) + \text{LSW}$$

or

$$\text{count} = (\text{MSW} \ll 16) | \text{LSW} \quad [\text{bit shift high order word by 16 bits and xor against low order word}]$$

Pulse count registers accumulate a total number of pulses received on each pulse input. The pulse count totals always increment and can not be cleared or set to an arbitrary value to prevent tampering. All pulse count totals are stored in non-volatile memory to preserve counts during power failure. The unsigned 32 bit counter values can accumulate up to 4.29 billion (2³²) pulses before rollover.

All 32 bit data point values are encoded in 2 Modbus registers (16bits each). Modbus master systems should always query the A8332-8F2D using a single query to read an entire block of registers. Never use two queries to read one register and then combine the two results into a single 32 bit value. Doing so will allow the pulse count to increment in the middle of the two Modbus queries, and will cause intermittent data readings that are incorrect.

For example, a pulse input has a count of 65534. This is represented as a 32 bit hex number 0x0000FFFE. The first 4 digits are the MSW register, the second 4 digits are the LSW register. The Modbus Master reads the first (MSW) register and gets 0x0000. In between the two readings, the pulse input counts 2 more pulses, making the total 65536 or 0x00010000 in hex. Next the Master reads the second (LSW) register and gets 0x0000. When the two registers are combined, the result is 0x00000000. The proper way to handle this situation is to simply read both registers in a single Modbus query.

Mechanical Drawings

DIN-Rail (EN50022) mount package: Width 105mm (6 modules)

