

Connections overview

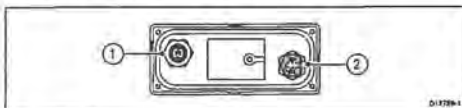

1. Alternate power connector
2. Network / PoE connector

The alternate power connector is required when connecting to a network which does not support Power over Ethernet PoE. The alternate power connector must be connected directly to a power supply.

Note: Do not connect the alternate power connector to a SeaTalk^{ng} network.

Note: Only use one power source. There is no need to connect the alternate power connector when the keypad is being supplied PoE.

Alternate power connection

When the keypad is not supplied Power over Ethernet (PoE) then the alternate power connection should be connected directly to a 12 V dc or 24 V dc power supply.

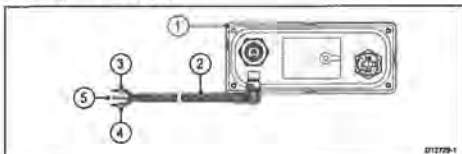

1. Keypad
2. Right angled power cable
3. Black negative wire
4. Red positive wire
5. Ground

5. Ground / shield wire



Warning: Product grounding

Before applying power to this product, ensure it has been correctly grounded, in accordance with the instructions provided.

In-line fuse and thermal breaker ratings

The following in-line fuse and thermal breaker ratings apply to your product:

In-line fuse rating	Thermal breaker rating
1 A slow blow	1 A (if only connecting one device)

Note:

- The suitable fuse rating for the thermal breaker is dependent on the number of devices you are connecting. If in doubt consult an authorized FLIR dealer.

- Your product's power cable may have a fitted in-line fuse, if not then you can add an in-line fuse to the positive wire of your product's power connection.

Grounding — Dedicated drain wire

The power cable supplied with this product includes a dedicated shield (drain) wire for connection to a vessel's RF ground point.

It is important that an effective RF ground is connected to the system. A single ground point should be used for all equipment. The unit can be grounded by connecting the shield (drain) wire of the power cable to the vessel's RF ground point.

On vessels without an RF ground system the shield (drain) wire should be connected directly to the negative battery terminal.

The dc power system should be either:

- Negative grounded, with the negative battery terminal connected to the vessel's ground.
- Floating, with neither battery terminal connected to the vessel's ground



Warning: Positive ground systems

Do not connect this unit to a system which has positive grounding.

Flush mounting the keypad

Flush mounting provides a sleek installation where the product and dash are flush, with only the buttons and Rotary controller protruding from the dash. Flush mounting requires the mounting surface to be rebated.

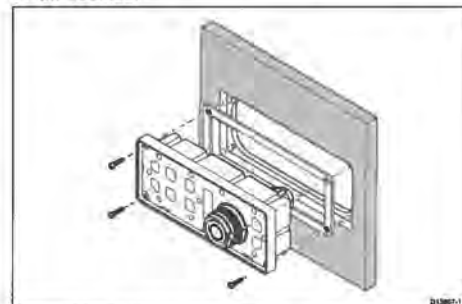

1. Check the selected location for the unit. A clear, flat area with suitable clearance behind the panel is required.
2. Before modifying the mounting surface, refer to the dimensions supplied in this document to

PAGE 2

ensure there is enough space for the unit and all cables.

3. Fix the supplied mounting template to the selected location, using masking or self adhesive tape.
4. Drill 4 holes as indicated on the mounting template to accept the fixings.
5. Using a suitable hole saw (the size and position is indicated on the template), make a hole in each corner of the cut-out area.
6. Using a suitable saw, cut along the inside edge of the cut-out line.
7. Using a Router, follow the Flush mount rebate line, to cut out a rebate to the specified rebate depth, as indicated on the template.
8. Ensure that the unit fits into the removed area and then remove rough edges.
9. Place the supplied gasket onto the rear of the keypad, ensuring the mounting holes are aligned.
10. Connect the relevant cables to the unit.
11. Place the keypad into the rebate and secure using the fixings provided.

Note: The appropriate tightening torque and drill bit size to use depends on the thickness of the mounting surface and the type of material it is made from.

Note: The supplied gasket provides a seal between the unit and a suitably flat and stiff mounting surface or binnacle. The gasket should be used in all installations. It may also be necessary to use a marine-grade sealant if the mounting surface or binnacle is not entirely flat and stiff or has a rough surface finish.

Surface mounting the keypad

Surface mounting provides a uniform installation where the products protrude, usually by the thickness of the bezel, from the mounting surface.

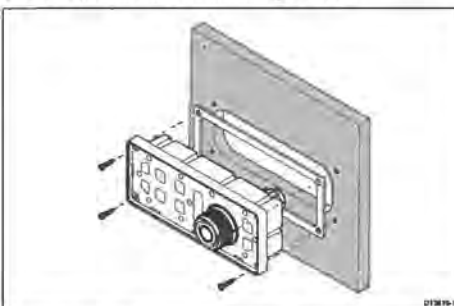

1. Check the selected location for the unit. A clear, flat area with suitable clearance behind the panel is required.
2. Before modifying the mounting surface, refer to the dimensions supplied in this document to ensure there is enough space for the unit and all cables.
3. Fix the supplied mounting template to the selected location, using masking or self adhesive tape.
4. Drill 4 holes as indicated on the mounting template to accept the fixings.
5. Using a suitable hole saw, make a hole in each corner of the cut-out area.
6. Using a suitable saw, cut along the inside edge of the cut-out line.
7. Ensure that the unit fits into the removed area.

9. Connect the relevant cables to the unit.
10. Secure using the fixings provided.

Note: The appropriate tightening torque and drill bit size to use depends on the thickness of the mounting surface and the type of material it is made from.

Note: The supplied gasket provides a seal between the unit and a suitably flat and stiff mounting surface or binnacle. The gasket should be used in all installations. It may also be necessary to use a marine-grade sealant if the mounting surface or binnacle is not entirely flat and stiff or has a rough surface finish.

Fitting the keypad mat

Your keypad can be installed in portrait or landscape orientation. Keypad mats are available for each orientation.

- You should fit the keypad mat that matches your chosen mounting orientation.
- You should only fit the keypad mat after the unit has been secured to the mounting surface.

1. Ensure the keypad mat is orientated correctly.
2. Slide the keypad mat's shorter edge, with the 2 locking tabs, into the end of the keypad that has 2 notches to accept the tabs.

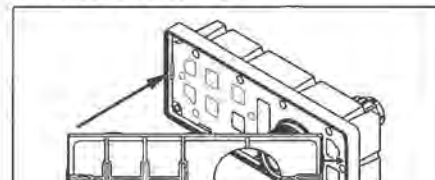

3. Close the opposite end of the keypad mat into the keypad, ensuring that the tab slides into the notch provided. Push all of the tabs on the

longer sides into their notches (you should hear a click as each tab engages).

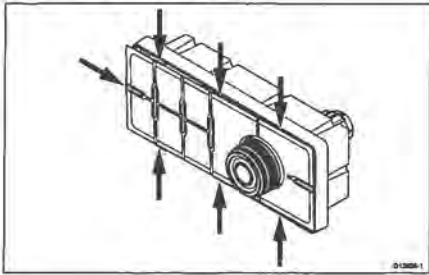

JCU-3 controls overview

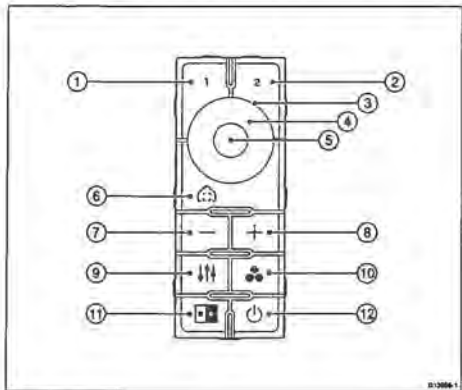

1	USER 1 • User configurable button (configured via camera web page).
2	USER 2 • User configurable button (configured via camera web page).
3, 4, 5	UNI-CONTROLLER – Use the uni-controller to control the camera: • Press ring (4) up, down left right – Pan / Tilt camera (pan available on M200-Series only). • Rotate outer ring (3) clockwise or counter-clockwise to pan the camera (pan available on M200-Series only). • Central button (5): long-press to toggle OSD MENU On/Off; short-press to select (OK). Navigate setup menus: • Move up, down – Scroll through menu options. • Press down – Select highlighted menu option.
6	HOME • Momentary press – Return camera to home position. • Press and hold – Set current position as camera home. • 4 x press – Reset the camera (realign home and stow positions).
7	ZOOM-OUT • Press to zoom thermal camera out.

8	ZOOM-IN • Press to zoom thermal camera in
9	SCENE • Press to cycle through image scene presets (day; night; docking; high contrast)
10	COLOR • Short-press to cycle through color palettes (WhiteHot; RedHot; Fusion; FireIce) • Long-press to toggle polarity of selected color palette (for example: WhiteHot > BlackHot > WhiteHot)
11	NEXT PAYLOAD • Short-press to switch to the next payload on the camera (applicable only to cameras with multiple payloads; for example: thermal and visible)
12	POWER • Short-press to cycle through keypad backlight brightness settings. • Long-press to put the camera into standby mode (parked and stowed); press any other button to wake the camera. • Double-press to switch to the next available camera in the network.

Pairing the keypad

Each JCU-3 keypad can be paired with multiple thermal cameras, and each thermal camera can be paired to multiple keypads.

Note: Pairing the keypad to a thermal camera requires a PC, laptop – or other IP-network compatible device that supports a web browser – to be connected to the same network as the camera and keypad.

You complete the pairing process using web pages served by the JCU-3 keypad.

- Make sure that your PC/laptop is configured to detect UPnP devices.

For example, in Windows 7, 8, and 10, within the **Network and Sharing Center**, you'll need to select the option to **Turn on network discovery**.
- The keypad is automatically added to the list of devices on your PC/laptop, and is named according to the keypad part number, and serial number (for example: **A80510 D123456**).

In Windows XP, the keypad is listed in Windows Explorer under "My Network Places"; in later versions of Windows, the keypad is listed in Windows Explorer under "Network".
- For Windows computers, double-click the keypad item to open the keypad's web page. You can also right-click the keypad item and select **Properties**, to show more information about the keypad, including its IP address.

The login screen with a picture of the JCU-3 is displayed.

- Enter **user** for Username and **user** for Password, then click **Login**.

The JCU configuration page is displayed.



- In the left-hand menu, click **CAMERAS**.

The camera pairing page is displayed.



- Click **Discover** to find all compatible cameras that are on the same network as the JCU-3.

The left-hand list, **DISCOVERED CAMERAS**, shows all compatible thermal cameras that were discovered.
- In the **DISCOVERED CAMERAS** list, select the camera you wish to pair with the JCU-3, and

The keypad's LED backlight flashes twice to indicate that pairing was successful. See for further information on keypad LED status.

The chosen camera is now paired with the JCU-3 keypad, and moved to the **SELECTED CAMERAS** list. Repeat this step for any additional cameras that you want to pair with the JCU-3. When you leave the JCU-3 Configuration pages the JCU-3 keypad remembers the selected cameras, and will cycle through the camera list (if you paired the keypad to more than one camera) when you click the **NEXT CAMERA** button on the keypad.

- Optionally, before leaving the JCU-3 Configuration pages, you can manually connect to one of the cameras in the **SELECTED CAMERAS** list, to confirm that you can control the camera with the JCU-3 keypad. In the **Camera Connect** list, highlight the camera you want to connect to and click **Select**.

The JCU-3 keypad connects to the camera; you can now control the camera from the keypad. The top-right of the **CAMERAS** page (directly underneath the **Logout** button) shows **Camera Connected**, and lists the name of the connected camera.
- When you have finished pairing cameras and testing connections, click the **Logout** button at the top-right of the page, then close your web browser.