

STORMWATCH

DRAIN MONITORING KIT

Code 7446-01



■ OVERVIEW

According to the U.S. Census Bureau, the world's population went from 2.5 billion in 1950 to 6 billion in 2000 and is on pace to exceed 9 billion by 2050. We will soon have 3 times the global population we had only in 1950, and with this growth comes enormous impacts on the surface of our globe. As buildings and pavement expand so do our obligations to control stormwater effluents. Urban development creates new pollution, which can either be washed or directly dumped into storm sewer systems, and ultimately into our waterways and coastal areas. Storm runoff leaving developed urban areas is significantly greater in inorganic content than runoff from the same area prior to development.

Stormwater is typically defined as water that is created as a result of a precipitation event. This water may flow through any path (gully, stream, conduit, channel, etc.) or adjacent area that is subject to overflow or flood water generated from that event. This water passes through a wide variety of natural or artificial environments, often sweeping organic and inorganic constituents into the watercourse through municipal storm drain systems. These environments can include pipeline projects, construction sites, landscaped areas, agricultural runoff, irrigation ditches, industrial sites, and a variety of other sources. In most cases this material is eventually fed into a stream, river, or other waterway, contributing to the overall pollutant load in that body of water.



While onsite sampling and offsite testing can be completed over the course of a number of days, the source of this outfall continues to contaminate the watercourse with both inorganic and organic constituents during subsequent precipitation events. A means is required by which to screen the outfall to potentially determine its source, the contribution it is making to the pollutant load, and the proper course of action to take.

Instrumentation and reagent systems are currently available to make measurements necessary to provide a preliminary screening of the outflow, and determine whether it is contributing to the overall pollutant load as it relates to inorganic constituents. In many cases these measurements can be made near the source, using handheld instrumentation and test kits, which may provide some indication as to the source and content of the outflow, or provide some indication of what additional testing is required.

EXAMPLES OF OUTFLOWS

Outflows attributable to a rainwater event can occur across a number of different environments.

These include:

- Agricultural runoff
- Industrial sites
- Construction sites
- Irrigation runoff
- Parking lots and pavement
- Other

While illicit discharges of various chemical constituents into stormwater drains represent a portion of the overall problem, these are not normally defined as stormwater events. These outflows can contain a wide variety of both inorganic and organic contaminants, and must be considered when characterizing the source of outflow. Inorganic constituents can often provide an indicator of such outflows when used in a manner that takes all indicators into account.

Where there are questions and concerns, either generated through the use of inorganic indicators, or when there are suspicions regarding organic contaminants, samples should be sent for further analysis.

While individual test measurements can be effectively used for screening outflows, long term trends are important after establishing baseline values for inorganic indicators [and organic indicators as needed].

MAKING MEASUREMENTS

Colorimetric

Colorimetric methods are based on the intensity of color produced by a chemical reaction. The color of the reaction is matched to a precision matched color bar using an Octa-Slide 2 Comparator.

Turbidimetric

The turbidity concentration is determined by the degree to which black lines on the tube are obscured when compared to calibrated targets.

Detergent

Anionic surfactants are extracted with toluene and break up an ion pair, releasing bromphenol blue into a water layer.

Electrometric pH

When the TRACER is immersed in the sample, the meter measures the difference in electrical potential between the electrode and the reference electrode. The electronic measurement is converted from millivolts to pH units, and the result appears on the display.

INDICATORS

Chlorine

Chlorine is used throughout the country to disinfect tap water, except where private wells provide the water supply. Unfortunately, chlorine is extremely volatile, and even moderate levels of organic materials can cause chlorine levels to drop below detection levels. Because chlorine is unstable, it is not a reliable indicator, although if very high chlorine levels are measured, it is a strong indication of a water line break, swimming pool discharge, or industrial discharge from a chlorine bleaching process.

Copper

Copper can arise from the corrosive actions of water leaching copper from copper pipes in building condensate systems and heat exchangers. High concentrations of copper can come from a variety of other sources including vehicle brake pads, pesticides and soil erosion, plating operations, vehicle fluid leaks and dumping.

Phenols

Phenols are used in heavy or industrial cleaning solutions, plating operations, coal coking and refinery operations. They are also a product of plating operations and are used as an anticaking ingredient in road salts.

Turbidity

Turbidity in water is caused by suspended particles or colloidal matter that obstructs light transmission through the water. It may be caused by inorganic or organic matter or a combination of the two. Microorganisms (bacteria, viruses and protozoa) are typically attached to particulates. Turbidity in some groundwater sources is a consequence of inert clay or chalk particles or the precipitation of nonsoluble reduced iron and other oxides. Turbidity in surface waters may be the result of particulate matter of many types and is more likely to include attached microorganisms that are a threat to health.

Detergents

In many countries, persistent types of anionic detergent have been replaced by others that are more easily biodegraded, and hence the levels found in water sources have decreased substantially. The concentration of detergents should not be allowed to reach levels giving rise to either foaming or taste problems. The presence of any detergent may indicate contamination of source water with sewage or ingress of detergent solution into the distribution system, as a result of back-flow, for example.

pH

Most discharge flow types are neutral, having a pH value around 7, although groundwater concentrations can be somewhat variable. pH is a reasonably good indicator for liquid wastes from industries, which can have very high or low pH (ranging from 3 to 12). The pH of residential wash water tends to be rather basic (pH of 8 or 9). Although pH data is often not conclusive by itself, it can identify problem outfalls that merit follow-up investigations. Normal rainwater has a pH of approximately 5.6

Test Factor	Methodology	Action Level
Total Residual Chlorine	Combined forms of chlorine react with DPD in the presence of potassium iodide to produce a red color. Color is compared to a known standard using a comparator.	≥0.30 ppm
Total Copper	Copper ions form a yellow colored chelate with diethyldithiocarbamate around pH 9-10 in proportion to the concentration of copper in the sample. Color is compared to a known standard using a comparator.	≥0.50 ppm
Total Phenol	4-Aminoantipyrine is oxidized in the presence of all ortho- and meta-substituted phenols to form a colored complex in proportion to the amount of phenol present. Color is compared to a known standard using a comparator.	≥1.00 ppm
Turbidity	The turbidity is determined by comparing the degree to which black lines on a tube are obscured by the sample when compared to targets in a comparator.	Non specified
Detergents [Surfactants]	The presence of LAS [Linear Alkylbenzene Sulfonate] in the water sample causes the transfer of bromphenol blue dye from the organic reagent layer to the aqueous layer. The amount of color in the aqueous layer is proportional to the concentration of the LAS in the sample.	≥0.40 ppm
pH	An ion specific electrode is used to measure potential across the salt bridge created by an electronic meter with a probe.	<6 or >9

USE OF THE OCTA-SLIDE 2 VIEWER

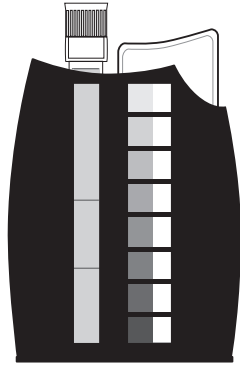

The Octa-Slide 2 Viewer should be held so non-direct light enters through the back of the Viewer. Insert the reacted sample into the top of the Viewer. Slide the Octa-Slide 2 Bar into the Viewer and match the color of the reaction to the color standards.

GLASSWARE CLEANING PROCEDURE

It is important to rinse test tubes with Deionized Water, three times in succession, after each test procedure is completed. At the end of each day, all sampling and test glassware should be brushed with a test tube brush (0514) and dilute dishwashing detergent and rinsed three times with Deionized Water.

To avoid possible detergent test interference, do not use detergent to clean Detergent Bottle (0800), rinse three times with Deionized Water only.





FIELD TEST PROCEDURES

TOTAL RESIDUAL CHLORINE

QUANTITY	CONTENTS	CODE
50	Chlorine DPD #4R Tablets	6899A-J
2	Test Tube, 2.5-5-10 mL, plastic, w/caps	0106
1	Chlorine Octa-Slide 2 Bar, 0.2-3.0 ppm	3401-01

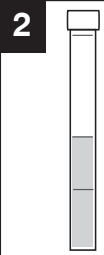
*WARNING: Reagents marked with an * are considered to be potential health hazards. To view or

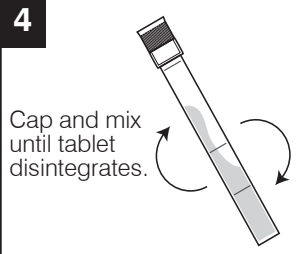
PROCEDURE





<p>1</p>  <p>Insert Chlorine Octa-Slide 2 Bar (3401-01) into the Octa-Slide 2 Viewer (1101).</p>	<p>2</p>  <p>Fill a test tube (0106) to the 5 mL line with the water sample.</p>	<p>3</p>  <p>Add one Chlorine DPD #4R Tablet (6899A).</p>
<p>4</p>  <p>Cap and mix until tablet disintegrates.</p>	<p>5</p>  <p>Insert test tube into Octa-Slide 2 Viewer.</p>	<p>6</p>  <p>Match sample color to a color standard. Record as ppm Total Residual Chlorine.</p>

COPPER

QUANTITY	CONTENTS	CODE
30 mL	*Copper 1	*6446-G
2	Test Tube, 2.5-5-10 mL, plastic, w/caps	0106
1	Copper Octa-Slide 2 bar, 0-4.0 ppm	3435-01

*WARNING: Reagents marked with an * are considered to be potential health hazards. To view or

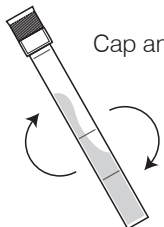
PROCEDURE





<p>1</p>  <p>Insert the Copper Octa-Slide 2 bar (3435-01) into the Octa-Slide 2 Viewer (1101).</p>	<p>2</p>  <p>Fill a test tube (0106) to the 10 mL line with sample water.</p>	<p>3</p>  <p>Add 5 drops of *Copper 1 (6446).</p>
<p>4</p>  <p>Cap and mix.</p>	<p>5</p>  <p>Insert test tube into Octa-Slide 2 Viewer.</p>	<p>6</p>  <p>Match sample color to a color standard. Record as ppm Copper.</p>

PHENOLS

QUANTITY	CONTENTS	CODE
10 g	Aminoantipyrine Reagent	7825-D
60 mL	*Ammonia Hydroxide Solution	*7826-H
2 x 100 mL	Potassium Ferricyanide Solution	7827-J
1	Spoon, 0.1 g	0699
1	Pipet, plain, glass, w/cap	0344
1	Pipet Assembly, 1.0 mL, plastic, w/cap	0330
2	Test Tube, plastic, w/caps	0106
1	Phenols Octa-Slide 2 bar, 0-5 ppm	3434-01
1	Sample Reaction Tube	0837

*WARNING: Reagents marked with an * are considered to be potential health hazards. To view or

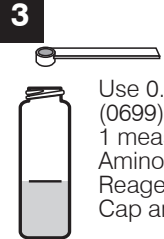

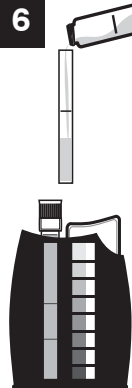

PROCEDURE

<p>1</p>  <p>Insert the Phenols Octa-Slide 2 bar (3434-01) into the Octa-Slide 2 Viewer (1101).</p>	<p>2</p>  <p>Fill Sample Reaction Tube (0837) to the line with sample water.</p>	<p>3</p>  <p>Use 0.1 g spoon (0699) to add 1 measure of Aminoantipyrine Reagent (7825). Cap and mix.</p>
<p>4</p>  <p>Use the unmarked pipet (0344) to add 4 drops of *Ammonium Hydroxide Solution (7826). Cap and mix.</p>	<p>5</p>  <p>Use the 1.0 mL pipet (0330) to add 2 mL (2 measures) of Potassium Ferricyanide Solution (7827). Cap and mix. Solution will turn orange/pink if phenols are present.</p>	<p>6</p>  <p>Fill test tube (0106) to 10 mL line with solution. Cap. Insert tube into Octa-Slide Viewer (1101). Match sample color to a color standard. Record as ppm Phenols.</p>

TURBIDITY

QUANTITY	CONTENTS	CODE
2	Test Tube, 2.5-5-10 mL, plastic, w/caps, with line	0106-WL
1	Turbidity Octa-Slide 2 bar, Low-Med-High	3436-01

PROCEDURE

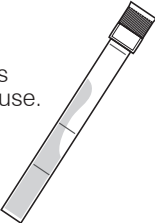
<p>1</p>  <p>Insert Turbidity Octa-Slide 2 Bar (3436-01) into the Octa-Slide 2 Viewer (1101).</p>	<p>2</p>  <p>Fill a test tube (0106-WL) to the 10 mL line with sample water.</p>	<p>3</p>  <p>Insert test tube into the Octa-Slide 2 Viewer with the printing on the tube facing away from the operator.</p>
<p>4</p>  <p>Match sample with the standards by comparing the degree to which the black lines are obscured by the turbidity (cloudiness) of the sample.</p>	<p>5</p>  <p>Disregard any differences in color between the sample and the standards. The test is based on the degree of turbidity, not color. Record as Low, Medium or High.</p>	<p>NOTE:</p> <p>Thoroughly clean tubes after each use.</p> 





Low	0-50 FTUs
Medium	75-150 FTUs
High	200-500 FTUs

DETERGENT

QUANTITY	CONTENTS	CODE
60 g	Detergent Reagent #1	7444-H
3 x 100 mL	*Detergent Reagent #2	*6037-J
100 mL	*Detergent Reagent #3	*7445-J
1	Pipet, 0.5 mL, glass, w/cap	0335
1	Spoon, 1.0 g	0697
1	French Bottle, Calibrated to 65 & 75 mL	0800

*WARNING: Reagents marked with an * are considered to be potential health hazards. To view or

PROCEDURE

<p>1 Fill bottle (0800) to 65 mL line with sample water.</p> 	<p>2 Use the 1.0 g spoon (0697) to add 2 measures of Detergent Reagent #1 (7444).</p> 	<p>3 Shake until dissolved.</p> 
<p>4 Fill to 75 mL line with Detergent Reagent #2.</p> 	<p>5 Use pipet (0335) to add 0.5 mL *Detergent #3 (7445). Shake vigorously for 15 seconds. Wait until layers separate (20-30 seconds). If the top layer is light blue, less than 0.1 mL detergent is present and no further testing is necessary. If top layer is colorless, continue adding *Detergent Reagent #3, 0.5 mL at a time, shaking vigorously for 15 seconds after each addition, allowing the layers to separate until the top layer is light blue. Count the number of additions of 0.5 mL of *Detergent Reagent #3 required to change the top layer from colorless to light blue.</p> 	
<p>6</p> <p>Detergent concentrations in ppm = (Number of pipets Detergent # 3 -1) x 0.1</p> <p>Example: It takes 9 pipets to turn the top layer blue. $[9-1] \times 0.1 = 0.8$. The amount of detergent is greater than 0.7 ppm but less than 0.9 ppm detergent.</p>		

pH · TRACER

For complete instructions, see the TRACER manual.

Before first use, hold the meter by the top battery compartment and swiftly tap the back of the meter downward into your palm (not a hard surface). This assures that the internal electrolyte moves to the very tip of the electrode. The electrolyte should fill the circular junction window at the tip of the electrode.



Before first use or after storage, soak the electrode in tap water or pH buffer solution for about 10 minutes.

For the most accurate results, allow sufficient time for the temperature of the probe to reach the temperature of the sample before calibrating. This will be indicated by a stable temperature reading on the display.

CALIBRATION

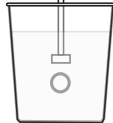

The TRACER can be calibrated at 1, 2 or 3 points. For the most accurate results with a two point calibration, calibrate the TRACER with a pH 7 buffer first, then calibrate with either a pH 4 or pH 10 buffer whichever is closest to the pH value of the sample to be tested. When performing a three point calibration, calibrate with the pH 7 buffer first, followed with the pH 4 buffer and then the pH 10 buffer.

Preparation of Buffers

<p>1</p> <p>Fill a sample cup with 20 mL of distilled or deionized water.</p> 	<p>2</p> <p>Add one buffer tablet:</p> <p>pH 4.0 Code 3983A</p> <p>OR</p> <p>pH 7.0 Code 3984A</p> <p>OR</p> <p>pH 10.0 Code 3985A.</p> 	<p>3</p> <p>Use the tablet crusher (0175) to crush the tablet. Stir until the tablet has disintegrated.</p> 
--	--	---





NOTE: Buffers should be prepared fresh daily.

Calibration

<p>1 Fill a sample cup to the 20 mL line with a buffer solution.</p> 	<p>2 Press the ON/OFF button to turn the TRACER ON.</p> 	<p>3 Place the electrode in the buffer solution. Press and hold the CAL/RECALL button until "CAL" appears in the lower display. The meter will automatically recognize the buffer and calibrate itself to that value. The circled number on the display will match the value of the buffer.</p> 
<p>4 During the calibration the pH value on the display will flash. When the calibration is complete, the TRACER will display "SA" and "End" and return to normal operation.</p>	<p>5 The appropriately circled indicator (L, M or H) will appear on the display when a calibration has been completed within one power on cycle.</p>	<p>6 For a two or three point calibration, repeat steps 1-5 with the remaining buffers.</p> <p>When the TRACER is turned off, the circled indicator configuration and the calibration data will be memorized.</p>

NOTE: If the buffer solution is more than 1 pH unit off from 4, 7, or 10, or the electrode slope is low, the meter will assume that there is an error and the calibration will be terminated. END will be displayed.

MEASUREMENT

<p>1 For small samples fill a sample cup to the 20 mL line with the test sample.</p>  <p>Sample depth must be greater than or equal to 1.5 inches.</p>	<p>2 Press the ON/OFF button.</p> 	<p>3 Immerse the TRACER in the sample. Make sure the electrode is completely submersed.</p> 
<p>4 Slowly stir the sample with the TRACER to remove air bubbles.</p> 	<p>5 The reading will flash until it has stabilized. This may take several seconds depending on the buffer capacity of the sample.</p>	<p>6 Rinse the electrode in distilled water. Replace the cap.</p>

KIT CONTENTS

Quantity	Contents	Code
50	Chlorine DPD #4R Tablets	6899A-H
30 mL	*Copper 1	*6446-G
10 g	Aminoantipyrine Reagent	7825-D
60 mL	*Ammonium Hydroxide Solution	*7826-H
2 x 100 mL	Potassium Ferricyanide Solution	7827-J
60 g	*Detergent Reagent #1	*7444-H
3 x 100 mL	*Detergent Reagent #2	*6037-J
100 mL	*Detergent Reagent #3	*7445-J
20	pH 4.0 MiniBuffer Tablets	----
20	pH 7.0 MiniBuffer Tablets	----
20	pH 10.0 MiniBuffer Tablets	----
1	Spoon, 0.1 g	0699
1	Spoon, 1.0 g	0697
1	Pipet, plain, glass, w/cap	0344
1	Pipet Assembly, 1.0 mL, plastic, w/cap	0330
1	Pipet Assembly, 0.5 mL, glass, w/cap	0335
2	Test Tubes, 2.5–10 mL, plastic, w/caps, with line	0106-WL
6	Test Tubes, 2.5–5–10 mL, plastic, w/caps	0106
1	Sample Reaction Tube, glass	0837
1	Bottle, French, calibrated to 65 & 75 mL	0800
1	Sample Cup, 20 mL, plastic	----
1	Tablet Crusher	0175
1	Test Tube Brush	0514
1	Chlorine Octa-Slide 2 Bar, 0.2–3.0 ppm	3401-01
1	Copper Octa-Slide 2 Bar, 0–4.0 ppm	3435-01
1	Phenols Octa-Slide 2 Bar, 0–5 ppm	3434-01
1	Turbidity Octa-Slide 2 Bar, Low-Med-High	3436-01
1	Octa-Slide Viewer	1101
1	TRACER, pH	----

***WARNING:** Reagents marked with an * are considered to be potential health hazards. To view or