

Model 6320

Electronic LCD Hour Meter



The Model 63 Electronic Hour Meter with 8 LCD digits bring together features, including optional programmable alert or preset capability, to control a significant process.

The front utilizes a high-contrast, reflective, 8-digit LCD with 0.32 inch [8mm] digits and seven icons, while at the back end Dry Contact, Low Voltage DC, and High Voltage DC and AC Inputs are available.

The Model 63 family is designed with a rugged plastic housing that is qualified to NEMA 4/4X when properly installed using the gasket supplied. In addition, the unit is compliant with CE EMC standards to EN61326:2001 for industrial applications, recognized by UL for U.S. and Canadian safety standards, and it is compliant to European RoHS and WEEE standards.

Key Features

- Reflective LCD Display with 8 large (8mm) digits
- Choice of hour meter types:
 - Hour Meter
 - Minutes Meter
 - Seconds Meter
- Choice of I/O complement that includes:
 - One or two inputs
 - Switch Input (No voltage)
 - Low DC Voltage (3-30VDC) <2mA
 - High Voltage (20-300VAC or 10-300VDC) <2mA
 - Control Inputs
 - External Electronic Reset
- Optional Front Panel Programming for flexible Redi-Alert or Preset functionality
- Optional Redi-Alert Functions:
 - 3 Redi-Alerts available with Front Panel Programming option
- Optional Preset Counter Mode:
 - Available with Front Panel Programming option
- NEMA 4/4X, 12, and IP66 rated
- EMC Compliant to EN61326:2001 for industrial environments
- CE compliant, UL and cUL recognized
- European WEEE & RoHS Compliant

Capabilities

Hour Meter Operation

Any of four different counting methods may be specified. These counting methods are factory set.

Hour Meter: The Hour Meter displays hours in a resolution of hours and tenths. A front panel programmable unit or a factory programmed unit can be programmed to display a resolution of 0.01 hours.

Minute Meter: The Minute Meter displays minutes to a displayed resolution of 0.1 minutes.

Seconds Meter: The Seconds Meter displays seconds to a displayed resolution of 0.1 seconds.

I/O Functions

The I/O functions can be mixed and matched to maximize the functionality of the Hour Meter. There are three types of inputs that the Hour Meter can accept. The interfaces for each are factory set. The inputs can be:

- Switch – open circuit or switch closure
- Low Voltage DC – Low input is less than 1VDC and High Input is 3 – 30VDC.
- High Voltage DC or AC – Low is less than 3VDC or 3VAC. A High Input is either 10 – 300VDC or 20-300VAC.

For the Switch and Low Voltage DC Hour Meters, there are six screw terminals for all of the I/O. For the High Voltage Hour Meters, there are four screw terminals for the I/O. The combinations of the I/O and power supply are factory set.

Enable Inputs: The enable inputs are those inputs that enable the accumulation of time.
 Remote Reset: When the remote reset is at a high level, the Hour Meter will reset.
 Front Panel Reset Enable: The Hour Meter will reset when the Front Panel Reset Enable is at a high level, and the Front Panel Reset Switch is pressed. The Hour Meter will not reset when the Front Panel Reset Enable is at a low level and the Front Panel Reset Switch is pressed.

Optional Preset Function

Each Hour Meter may be placed in a preset operating mode. This mode can be programmed through the front panel for those units that have the front panel programming option. It may also be factory programmed. **IT IS NOT RECOMMENDED THAT THE PRESET FUNCTION BE USED AT THE SAME TIME THAT ALERTS ARE ENABLED.**

The preset Hour Meters can be set up for either automatic reset or external (front panel or remote) reset.

Optional Alert Functions

The Model 63 Hour Meter can be programmed to operate as a maintenance device in which alerts notify the user of certain maintenance actions to be taken after accumulation of a predefined time. When the accumulated time equals the predefined alert value, an icon is illuminated on the display. When the alert is reset, the icon is turned off, but the accumulated time is not reset.

There are two types of alerts. The first is a break-in alert. A break-in alert only occurs once at the start of unit operation. The second type of alert is recurring. A recurring alert occurs continuously at a predefined period. When tied to a break-in alert, the recurring alert will not begin its count until the break-in alert has occurred. The intervals for the recurring alert can be performed as start-to-start or end-to-start. A start-to-start interval count starts when the last alert is turned on. The end-to-start interval count starts when the last alert is turned off.

The Model 63 Hour Meter can support three alerts using front panel programming and four alerts when factory programmed. **IT IS NOT RECOMMENDED THAT THE PRESET FUNCTION BE USED AT THE SAME TIME THAT ALERTS ARE ENABLED.** In both cases, Alert #1 is a break-in alert that is tied to Alert #2, which is recurring. Alert #3 is recurring, and Alert #4 can be factory set as either break-in or recurring. If Alert #4 is break-in, then it is tied to Alert #3.

The Model 63 Hour Meter can be programmed to be latched or kept on for a predetermined time. When latched, an external reset is required to turn off the alert.

Front Panel

The liquid crystal display is reflective with dark characters on a light background. There are 8 digits on the display. The standard display contains seven icons which can be assigned as desired to either alerts or a preset.

Model 63 Hour Meters with the front panel programming option are capable of being programmed for either alerts or the preset function. There are two front panel switches. To begin programming, the two switches are pressed simultaneously. The programming menu must be completed in its entirety to return to normal operation. The switch functions are described as follows:

- | | |
|------|--|
| SEL: | During normal operation, the displayed Hour Meters will be swapped when the SEL switch is pressed and released. During programming, this switch is used to select options. |
| RST: | During normal operation, the RST switch is used for front panel reset. During programming, the RST switch is used to enter an option. |

Resets

Unless using alerts, a reset returns the display to zero. If using alerts, the reset turns an alert off. There are three different reset configurations available:

Non-Reset: The Hour Meter can never be reset. A non-reset unit also has no front panel programming option.

Remote Reset: A model with Remote reset has a dedicated terminal for performing the reset function. The unit resets when the remote reset signal is at a high level. When the reset signal is at a low level, accumulating time can occur.

Manual Reset: Manual reset occurs when the RST switch on the front of the Hour Meter is pressed. Accumulating time resumes upon release of the RST switch. The exception to this operation is in the Dual Hour Meter case; the non-resettable Hour Meter can not be reset.

Common Specifications

Display	Figures: 8 LCD digits 0.32" [8mm] high Annunciators Icon: A choice of 7 Icons 0.08" [2mm] high	Terminations:	Terminal block
Reset:	Remote, manual & non-reset. Manual reset enable is available on some models	Weight:	2 oz. [57g]
Speed:	Low speed: 0-40 counts per second (min. 12.5ms-on, 12.5ms-off) High speed: 0-500 counts per second (min. 1.0 ms-on, 1.0 ms-off)	Environmental:	Temp. (Storage & Operating): -4°F to + 140°F [-20°C to +60°C] Humidity: 0 to 95% RH, non-condensing
Inputs	Switch (no voltage) <i>DC Voltage:</i> Absolute voltage range: -0.5 VDC, minimum to 30.0VDC, maximum VIH: 3.0 VDC, maximum VIL: 1.0 VDC, minimum <i>High Voltage AC/DC:</i> Absolute Maximum voltage: 300VAC/VDC VIH: 10VDC/20 VAC, max. VIL: 3VDC/3 VAC, minimum	Vibration:	Operating: 10 to 55 Hz, 0.01" [0.25mm] double amplitude Non-operating: 10 to 55 Hz, 0.03" [0.75mm] double amplitude
Power:	Internally powered models: Self powered (+15yrs lithium battery)	Shock:	Operating: 10G's Non-operating: 30G's
Battery Life:	15 years +	Dielectric:	1000 VAC 50/60Hz for 1 minute
Mounting:	Panel with clip	Accuracy:	100% (provided signal meets stated parameters)
		EMC Compliance:	EN61326:1997 with A1: 1998 & A2:2001 for industrial environments
		Enclosure:	NEMA 4/4X, 12, & IP66 compliance (from the front) when properly mounted using the optional gasket
		Approvals:	CE compliant, UL & cUL recognized
		Environmental Compliance:	Compliant to the European WEEE & RoHS

Notes

- When interfacing the Model 63 with a Solid State Relay or AC Sensor, the leakage current needs to be considered.
- The Absolute Voltage Range and the Absolute Maximum Voltage are the voltages at which operation beyond the specified limits may result in damage to the unit.

Product Dimensions

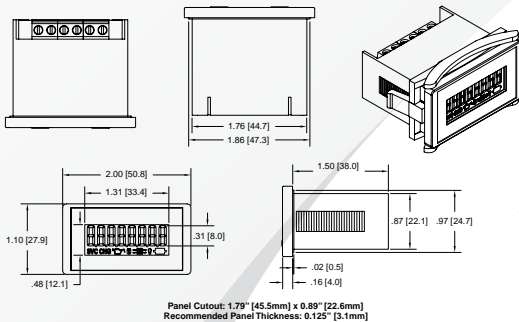

Available Icons

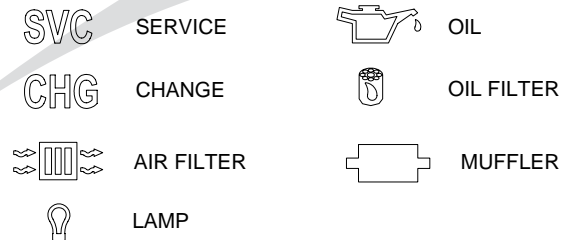

Part Numbers

Part Number	Description	Gasket
6320-0000-0000	HOUR METER DRY CONTACT INPUT REMOTE RESET	5003-013
6320-0500-0000	HOUR METER DRY CONTACT INPUT PROGRAMMING/FPRESET inc REDI-ALERTS	5003-013
6320-1000-0000	HOUR METER 3-30 VDC INPUT REMOTE RESET	5003-013
6320-1500-0000	HOUR METER 3-30 VDC INPUT PROGRAMMING/FPRESET inc REDI-ALERTS	5003-013
6320-2000-0000	HOUR METER 10-300/20-300 VDC/VAC INPUT REMOTE RESET	5003-013
6320-2500-0000	HOUR METER 10-300/20-300 VDC/VAC INPUT PROGRAMMING/FPRESET inc REDI-ALERTS	5003-013
720-6300	HOUR METER 85-500VAC INPUT NON-RESET 6" LEADS SPECIAL HIGH VOLTAGE IN A 3-HOLE ROUND STEEL CASE	

FOR FRONT PANEL PROGRAMMABLE PRESET AND REDI-ALERT OPTIONS PLEASE CONTACT US.

