



MONARCH INSTRUMENT

Instruction Manual



Pocket Laser Tach 200 (PLT200)

Tachometer / Rate Meter / Totalizer / Timer

SAFEGUARDS AND PRECAUTIONS

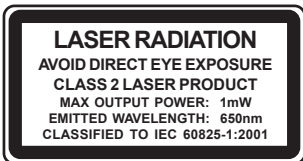

WARNING - This product emits a visible beam of laser light. Avoid exposure to the laser radiation. The use of optical viewing aids (binoculars, for example) may increase the ocular hazard.

CAUTION - The laser beam should not be intentionally aimed at people or animals.

CAUTION - Use of controls or adjustments or performance of procedures other than those specified herein may result in hazardous radiation exposure.



Read and follow all instructions in this manual carefully, and retain this manual for future reference.

Do not use this instrument in any manner inconsistent with these operating instructions or under any conditions that exceed the environmental specifications stated.

This instrument is not user serviceable. For technical assistance, contact the sales organization from which you purchased the product.



In order to comply with EU Directive 2002/96/EC on Waste Electrical and Electronic Equipment (WEEE): This product may contain material which could be hazardous to human health and the environment. DO NOT DISPOSE of this product as unsorted municipal waste. This product needs to be RECYCLED in accordance with local regulations, contact your local authorities for more information. This product may be returnable to your distributor for recycling - contact the distributor for details.

TABLE OF CONTENTS

1.0	OVERVIEW	E-1
2.0	FEATURE LOCATIONS	E-1
3.0	LCD DISPLAY SYMBOLS	E-2
4.0	PLT200 SPECIFICATIONS	E-3
5.0	INPUT / OUTPUT	E-7
6.0	PREPARATION FOR MEASUREMENT	E-8
6.1	Non-Contact Preparation	E-8
6.2	Direct Contact Preparation	E-8
6.3	Connecting External Sensors	E-9
7.0	TAKING MEASUREMENTS	E-10
7.1	Non-Contact Measurements	E-10
7.2	Direct Contact Measurements	E-10
8.0	TACHometer Mode	E-11
8.1	TACHometer Setup	E-11
8.2	TACHometer Operation	E-13
9.0	RATE Mode	E-13
9.1	RATE Setup	E-14
9.2	RATE Operation	E-16
10.0	TOTALizer Mode	E-17
10.1	TOTALizer Setup	E-17
10.2	TOTALizer Operation	E-20
11.0	TIMER Mode	E-21
11.1	TIMER Setup	E-21
11.2	TIMER Operation	E-22
12.0	BATTERIES	E-23
13.0	CLEANING	E-24
14.0	OPTIONS /ACCESSORIES	E-24

1.0 OVERVIEW

The Pocket Laser Tach 200 is a multifunction Tachometer, Ratemeter, Totalizer and Timer. It is programmable to read in English or Metric units. An input socket accepts remote sensing devices and an output socket allows for pulse output to external indicating devices. The PLT200 can be tripod mounted and “Locked-On” for accurate and continuous operation. This tachometer also stores minimum, maximum and last measurement in memory.

2.0 FEATURE LOCATIONS

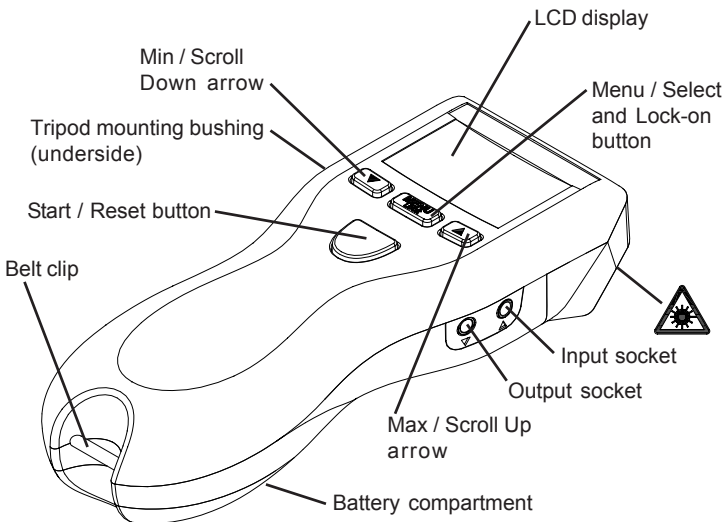

AVOID EXPOSURE - LASER RADIATION IS EMITTED FROM THIS APERTURE

3.0 LCD DISPLAY SYMBOLS

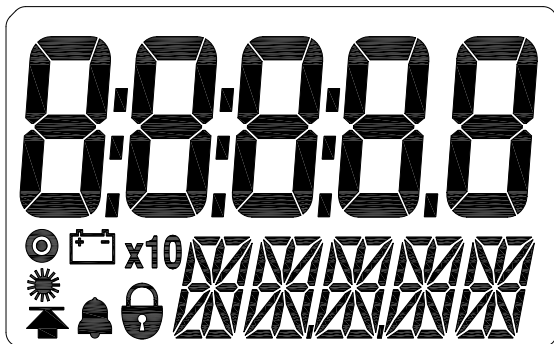

On Target Indicator. Blinks on whenever there is an input signal. Will appear to be solid on at higher frequencies.



Low Battery icon. Indicates that the batteries are low and need to be replaced.



Times Ten icon. Indicates that the value shown is ten times that which is displayed.



Laser Indicator. Red laser is on when this indicator is illuminated.



Lock icon. Indicates that the unit is “Locked” on and making continuous measurements (Lock mode).

4.0 PLT200 SPECIFICATIONS

Laser Specifications:

Classification: Class 2 (per IEC 60825-1 Ed 1.2 2001-8)
Complies with FDA performance standards for laser products except for deviations pursuant to Laser Notice No. 50, dated July 26, 2001.

Maximum Laser Output: 1mW
Pulse Duration: Continuous
Laser Wavelength: 650 nm
Beam Divergence: < 1.5 mrad
Beam Diameter: 4 x 7 mm typical at 2 meters
Laser Diode Life: 8,000 operating hours MTBF (1 year warranty)

Non-Contact Specifications:

Ranges: RPM 5 – 200,000
RPS 0.084 – 3,333.3
RPH 300-999,990

Resolution: Fixed: 1 (10 above 99,999)
Auto-ranging: 0.001 to 1.0 (10 above 99,999)

Accuracy: ±0.01% of reading or resolution limit

Operating Range: up to 25 feet (7.62 m) or up to 70 degrees off perpendicular to T-5 tape target

Contact Specifications using optional Remote Contact Assembly:

Range: Contact Tips: 0.5 to 20,000 RPM
10 cm / 12-inch Wheel: 0.5 to 12,000 RPM

Resolution: Fixed: 1 (10 above 99,999)
Auto-ranging: 0.001 to 1.0 (10 above 99,999)

Contact Specifications (continued):

Accuracy:	Revs:	$\pm 0.05\%$ of reading (RPM) or resolution limit (with no slippage)
	Linear:	$\pm 0.5\%$ of reading or resolution limit (with no slippage)

Contact Measurements Ranges:

TACHOMETER:

Revolutions per Minute (RPM)	0.5 to 20,000 RPM
Revolutions per Second (RPS)	0.0833 to 333.33 RPS
Revolution per Hour (RPH)	30 to 999,990 RPH

RATES:

Wheel Circumference:

Inches per Second	10 cm: 0.033 to 1312.3 IPS
	12 in: 0.100 to 2,400.0 IPS
Inches per Minute	10 cm: 1.969 to 78,740 IPM
	12 in: 6.000 to 144,000 IPM
Inches per Hour	10 cm: 118.11 to 999,990 IPH
	12 in: 360.00 to 999,990 IPH
Feet per Second	10 cm: 0.003 to 109.36 FT/S
	12 in: 0.009 to 200.00 FT/S
Feet per Minute	10 cm: 0.164 to 6,561.7 FT/M
	12 in: 0.500 to 12,000 FT/M
Feet per Hour	10 cm: 9.843 to 393,700 FT/H
	12 in: 30.000 to 720,000 FT/H
Yards per Second	10 cm: 0.001 to 36.453 YPS
	12 in: 0.003 to 66.667 YPS
Yards per Minute	10 cm: 0.055 to 2,187.2 YPM
	12 in: 0.167 to 4,000.0 YPM

Contact Measurements Ranges (continued):

RATES:

Yards per Hour

Wheel Circumference:

10cm: 3.281 to 131,233 YPH

12 in: 10.000 to 240,000 YPH

Miles per Hour

10 cm: 0.002 to 74.564 MPH

12 in: 0.006 to 136.36 MPH

Centimeters per Second

10 cm: 0.084 to 3,333.3 CM/S

12 in: 0.21 to 3,048.0 CM/S

Centimeters per Minute

10 cm: 5.000 to 200,000 CM/M

12 in: 15.240 to 365,760 CM/M

Centimeters per Hour

10 cm: 300.00 to 999,990 CM/H

12 in: 914.40 to 999,990 CM/H

Meters per Second

10 cm: 0.001 to 33.333 M/SEC

12 in: 0.003 to 60.960 M/SEC

Meters per Minute

10 cm: 0.050 to 2,000.0 M/MIN

12 in: 0.153 to 3,657.6 M/MIN

Meters per Hour

10 cm: 3.000 to 120,000 M/H

12 in: 9.144 to 219,460 M/H

TOTALIZER:

Counts: 0 to 999,999

Scale Totals in Inches, Feet, Yards, Centimeters or Meters

Input: Internal or External optics or linear contact wheel

Timer Specifications:

Minutes:Seconds.Tenths to 99:59.9

Accuracy: ±0.2 second

Resolution: 0.1 second

Display: Dual LCD Display (5-digit upper/scrolling, 5-digit alphanumeric lower display)

Batteries: 2 “AA” 1.5 V  (DC) alkaline included
(Note: Batteries are NOT rechargeable.)

Battery Life: 30 hours continuous typical with batteries provided

External Input:

Absolute max: -0.3 V to 5 V  (DC)

Minimum: low below 1.2 V and high above 2 V (TTL compatible)

Edge: Triggers on Positive edge

Power Out: 3.0 V nominal, approx. 2.8 V @ 20 mA max

Pulse Output: 0 V to 3.3 V  (DC) pulse
Same shape as External Input signal or high when internal optics sees a reflection

Dimensions: 6.92” (17.58 cm) H x 2.4” (6.10 cm) W x 1.6” (4.06 cm) D

Weight: Approx. 7 oz. (210 g)

This product is designed to be safe for indoor use under the following conditions (per IEC61010-1).

Installation Category II per IEC 664

Pollution Degree Level II per IEC 664

Temperature: 40 °F to 105 °F (5 °C to 40 °C)

Humidity: Maximum relative humidity of 80% for temperatures up to 88 °F (31 °C) decreasing linearly to 50% relative humidity at 100 °F (40 °C). Humidity non-condensing.

Specifications subject to change without notice.

5.0 INPUT / OUTPUT

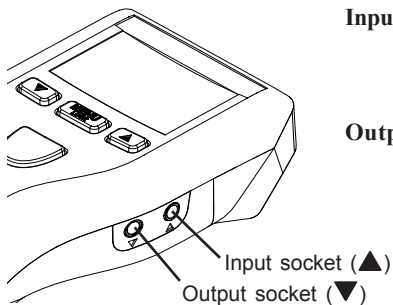

Input: Accepts remote sensor or Remote Contact Assembly (RCA). 1/8" (3.5mm) stereo phone plug.

Output: 1 pulse per revolution TTL output on internal operation. Pulse repeater with external sensors. 1/8" (3.5mm) mono phone plug.

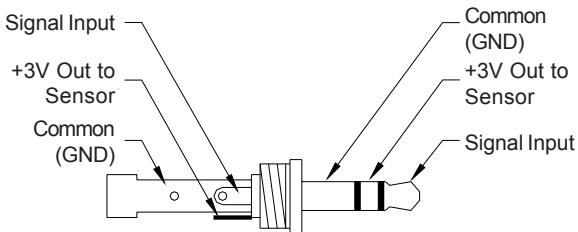

Input Connector Detail (Stereo plug)

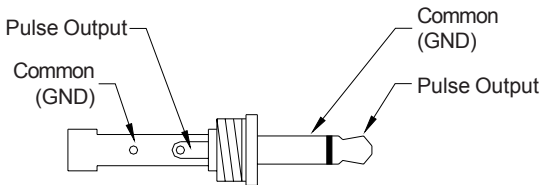

Output Connector Detail (Mono plug)

6.0 PREPARATION FOR MEASUREMENT

6.1 Non-Contact Preparation

For Internal operation (Red laser) or External operation using optional Remote Optical Sensor (ROS-Red LED).

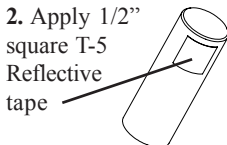

For Small Shafts:

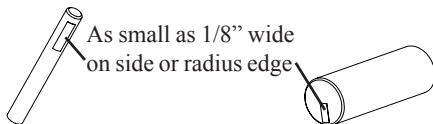

6.2 Direct Contact Preparation

For External operation ONLY using optional Remote Contact Assembly (RCA).

Select and install contact option:

1. Contact Tip (Convex tip shown. Use Concave tip for small shafts.)

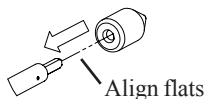

2. 10 cm Wheel

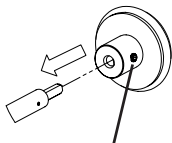

Tighten screw securely into flat on shaft.

OR

3. 12 inch Wheel

Install with pin in shaft fully seated in slot. Tighten screw.

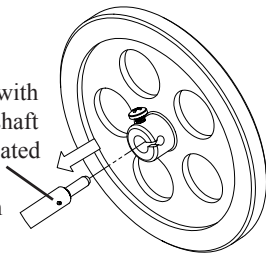

6.3 Connecting External Sensors

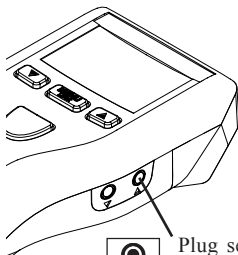

Plug sensor into Input socket



Remote Contact Assembly (RCA)

(shown with optional 12 inch wheel)



Remote Optical Sensor (ROS-P)



Infrared Sensor (IRS-P)



Magnetic Sensor with Amplifier (MT-190P)

7.0 TAKING MEASUREMENTS

7.1 Non-Contact Measurements

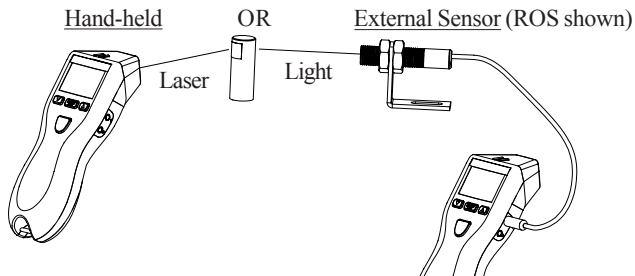

7.2 Direct Contact Measurements

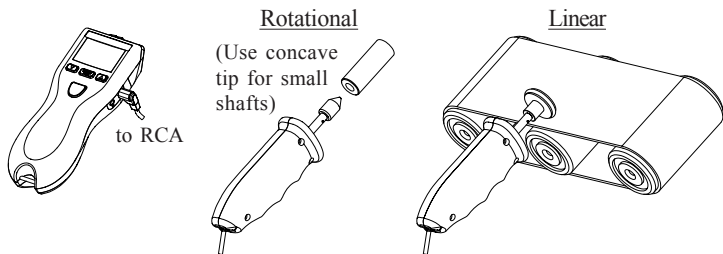

from PLT200

from PLT200



ONLY USE MODERATE PRESSURE

WARNING: Making measurements in direct contact with rotating equipment can be dangerous. Keep all loose clothing and hair away from exposed moving machinery. Keep the hand holding the instrument well behind the back end of the Remote Contact Assembly. Properly replace all machinery guards after completing measurement. Do not use for rotation greater than 20,000 RPM.

8.0 TACHometer Mode



Tachometer measures speed or linear rate with respect to time. Time intervals are seconds, minutes, or hours. Rotational speed can be measured in Revolutions (Revs) per second, per minute, or per hour. The most common measurement is RPM or Revs per minute using the optical tachometer mode.

8.1 TACHometer Setup

1. Turn Power ON

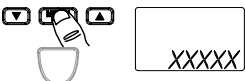
Last Units selected are displayed
- 1a. To toggle Lock On/Off
Press and Hold

Locked On
2. Enter Setup

3. Enter selection of Mode

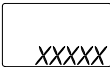
Last Mode selected is displayed
4. Select TACH Mode
 OR  Repeat until *TACH* displayed
5. Save and advance

6. Enter selection of Units   *RPS, RPM or RPH*

7. Select Units  OR  Repeat until desired Units displayed

8. Save and advance  

9. Enter selection of number of decimal places   *NONE, 1, 2 or 3*

10. Select decimal places  OR  Repeat until desired decimal places displayed

11. Save and advance  

12. Exit Setup – Ready to measure   *DONE, then Units selected*

Unit will remember these settings (including lock on/off) even if turned off and back on.

8.2 TACHometer Operation

Measure



Press and hold



Lock on

Recall Max

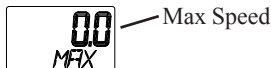

Recall Min

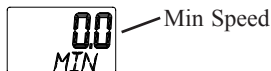

If unit Locked
on:



Resets Max/Min

Power OFF



OR Automatic after 90 seconds
if unit not Locked on

9.0 RATE Mode

Measurement of units in addition to Revs requires the attachment of the Remote Contact Assembly and tips/wheels. With this attachment, the unit can measure RATE inputs-revs, inches, feet, yards, centimeters and meters either per second, per minute or per hour, as well as miles per hour.

NOTE: External Remote Contact Assembly (RCA) must be inserted into input socket.



9.1 RATE Setup

1. Turn Power ON
 

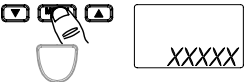
EXTRN, then scrolling message, then last Units selected
- 1a. To toggle Lock On/Off
 

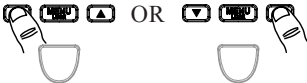
Press and Hold
Locked On
2. Enter Setup
 
3. Enter selection of Mode
 



Last Mode selected is displayed
4. Select RATE Mode
 

OR
Toggles between *RATE* and *TOTAL*.
Select *RATE*.
5. Save and advance
 
6. Enter selection of Units
 

Rotational: *CRPS*,
CRPM or *CRPH*









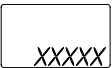

Linear: *IPS*, *IPM*, *IPH*, *FT/S*, *FT/M*, *FT/H*,
YPS, *YPM*, *YPH*, *MPH*, *CM/S*, *CM/M*, *CM/H*, *M/SEC*,
M/MIN, *M/H*

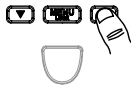
RATE Setup (continued):

7. Select Units  OR  Repeat until desired Units displayed

8. Save and advance   OR  Rotational Units Linear Units

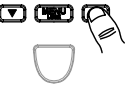
Only for Linear Units:

- 8a. Enter selection of Wheel   Last Wheel selected is displayed
- 8b. Select Wheel  OR  Toggles between 10CM and 12IN
- 8c. Save and Advance  
9. Enter selection of number of decimal places   NONE, 1, 2 or 3
10. Select decimal places  OR  Repeat until desired decimal places displayed
11. Save and advance  

12. Exit Setup – Ready to measure
- 
- 
- DONE, USE CONTACT TIP or [wheel selected], then Units selected*

Unit will remember these settings (including lock on/off) even if turned off and back on.

9.2 RATE Operation

Measure



OR





Press and hold

Lock on

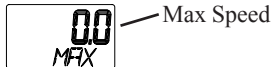
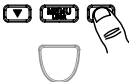
Recall Max

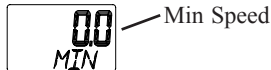

Recall Min



If unit Locked on:



Resets Max/Min



Power Off



OR Automatic after 90 seconds if unit not Locked on

Despliegue: 5 x 0.5" (12.7mm) dígitos numéricos más 5 alfanuméricos *LCD*

Baterías: 2 "AA" 1.5 V  (CC) alcalinos incluidas
(Notese: Baterías NO se pueden volver a cargar.)

Vida de Batería: típicamente 30 horas continuas con las baterías suministrados

Entada externa:

Máximo absoluto: -0.3 V a 5 V  (CC)

Mínimo: bajo a menos de 1.2 V y alto por encima de 2 V
(compatible con *TTL*)

Borde: Cambia en borde positivo

Potencia Salida: 3.0 V nominal, aprox. 2.8 V @ 20 mA max

Salida Pulso: 0 V a 3.3 V  (CC) pulso, Misma forma que la señal de entrada externa o alta cuando la óptica interna ve una reflexión

Dimensiones: 6.92" (17.58 cm) de alto x 2.4" (6.10 cm) de ancho x 1.6" (4.06 cm) de profundo

Peso: Aprox. 7 onzas. (210 g)

Este producto fue concebido para ser segura para uso interno bajo las siguientes condiciones (según IEC61010-1).

Categoría de instalación II según IEC 664

Grado de nivel de contaminación II según IEC 664

Temperatura: 40 °F a 105 °F (5 °C a 40 °C)

Humedad: Humedad relativa maxima de 80% para temperatures hasta 88 °F (31 °C) disminuyendo linealmente hasta un 50% de humedad relativa a una temperatura de 100 °F (40 °C).
Humedad sin condensar.

Especificaciones sujetos a cambios sin aviso previo.

5. Save and advance  



6. Enter selection of Units  Different options displayed for Internal or External operation.

Internal or External ROS:

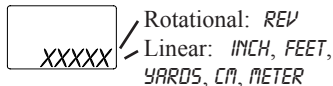

External Remote Contact Assembly:



7. Select Units  OR  Repeat until desired Units displayed

8. Save and advance   OR 
 COUNT or REV Linear Units



















Only for Linear Units:

- 8a. Enter selection of Wheel  

- 8b. Select Wheel  OR  Toggles between 10CM and 12IN

- 8c. Save and Advance  

TOTALizer Setup (continued):

9. Enter selection of number of decimal places     *NONE, 1, 2 or 3*
10. Select decimal places    OR    Repeat until desired decimal places displayed
11. Save and advance    
12. Exit Setup – Ready to measure     
- Units = COUNT:
DONE,
then *COUNT*
- Rotational/Linear Units:
DONE,
USE CONTACT TIP or
[wheel selected],
then Units selected

10.2 TOTALizer Operation

Measure



Press and hold



Lock on

Recall Max or Min



Max or Min Speed (in last selected Tach or Rate mode units)

Recall Time in seconds

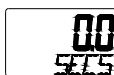

Shows time in seconds from when the Start / Reset button is pressed until the last input signal measured.

If unit is Locked on:



Resets Max/Min, Total and Measurement Time

Power Off



OR Automatic after 90 seconds if unit not Locked on

NOTE:
Pressing

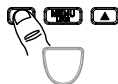









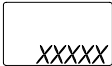





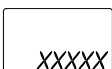



once before 90 seconds will keep measurements in memory and the display turned on longer.

11.0 TIMER Mode

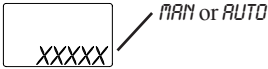
Accumulates time in minutes, seconds, and tenths of a second. There are two modes of operation. The Manual mode operates like a stopwatch, the timing period being started and stopped by the user. The Auto mode can be stopped and started by the user or a piece of reflective tape on objects. The user can freeze the display-and view/record a LAP time-at any time without affecting the count.

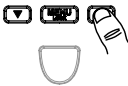
11.1 TIMER Setup



1. Turn Power ON   Last Units selected are displayed
- 1a. To toggle Lock On/Off   Locked On
Press and Hold
2. Enter Setup Mode  
3. Enter selection of Mode   Last Mode selected is displayed
4. Select TIMER Mode   OR  Repeat until *TIMER* displayed
5. Save and advance  

6. Enter selection of Timer function   *MAN or AUTO*
7. Select Timer function  OR  *Toggles between Manual and Auto*
8. Save and advance  
9. Exit Setup – Ready to measure   *DONE, then Units selected*

Unit will remember these settings (including lock on/off) even if turned off and back on.

11.2 TIMER Operation

Measure:

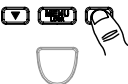
- | | | |
|--------|---|--|
| Manual |  | Each press toggles Start and Stop |
| Auto |  | OR Start and Stop triggered by external remote optical sensor (ROS) or internal optics |
| Reset |  | With Timer stopped - Resets time to 00:00.0 |

TIMER Operation (continued):

Lap

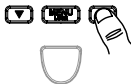

With Timer running -
Stops at elapsed time to date.
To continue, press again.

Power Off



OR If Timer stopped -
Automatic after 90 seconds
(if unit not Locked on)
Automatic after 99:59.9

OR

12.0 BATTERIES

When displayed, replace batteries.



Remove battery
cover

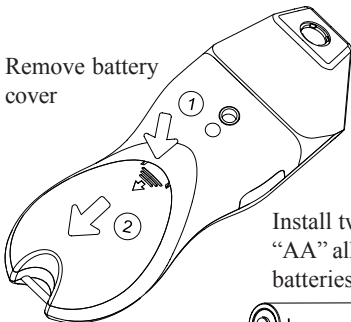

Install two 1.5V
“AA” alkaline
batteries

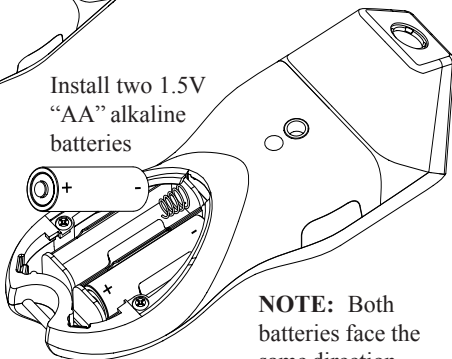

NOTE: Both
batteries face the
same direction.

13.0 CLEANING

To clean the instrument, wipe with a damp cloth using mild soapy solution.

14.0 OPTIONS /ACCESSORIES

T-5	Reflective Tape, 5 foot [1.5 m] roll, ½ inch [13 mm] wide
RCA	Remote Contact Assembly with 10 cm wheel, concave and convex tips
CTE	Concave/convex contact tips and 10 cm linear contact wheel
12 inch Wheel	12 inch circumference wheel for use with RCA
CA-4044-6	6 foot Input/Output cable, 1/8" mono phone plug to BNC connector
ROS-P	Remote Optical Sensor
ROS-P-25	Remote Optical Sensor with 25 foot cable
ROSM-5P	Remote Optical Sensor, modulated
MT-190-P	Amplified Magnetic Sensor
IRS-P	Infrared Sensor
EC-25P	25 foot extension cable for all sensors
CC-10	Padded Nylon Carrying Case
CC-11	Latching Carrying Case for Pocket Tach and accessories
CAL-N.I.S.T.	N.I.S.T. Traceable Certificate of Calibration