

# SmartLog Pro® Stand Installation and Maintenance



Made in the  
United States of America



Figure 1. EMIT 50416 SmartLog Pro® Stand

## Description

The EMIT [50416](#) Stand is designed as a mounting alternative for the EMIT [50780](#) SmartLog Pro®. It is constructed of heavy gauge steel and powder-coated for minimized contamination when used in clean areas. The SmartLog Pro® Stand allows administrators to setup the SmartLog Pro® in a convenient area on the floor when wall-mounting is not available.

## Packaging

- 1 Pedestal (Two-Pieces)
- 1 Base Plate
- 5 Socket Head Screws, 1/4-20 x 1/2"
- 2 Phillips Head Screws, 10-32 x 5/8"
- 2 Nuts, 10-32
- 1 Cable Port Cover

## Installation

1. Assemble the pedestal and base plate using the 5 socket head screws.

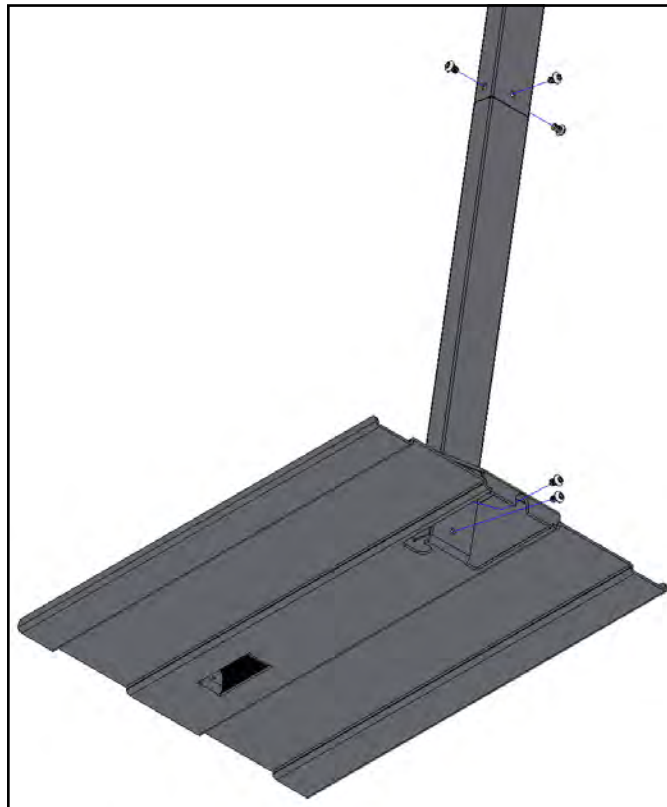

Figure 2. Assembling the pedestal and base plate using the 5 socket head screws

2. Align the SmartLog Pro® mounting bracket's top and bottom holes to the two holes on the pedestal's mounting bracket. Align the cable port cover with the bottom holes on both the mounting bracket and pedestal. Secure the mounting bracket and cable port cover to the pedestal using the two Phillips head screws and nuts.

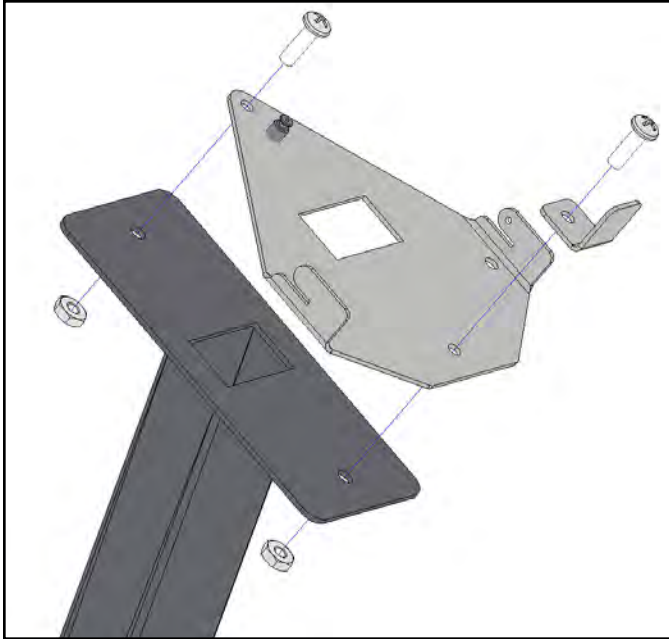

Figure 3. Securing the SmartLog Pro® mounting bracket to the pedestal

3. Route the ground cord, foot plate cable, Ethernet cable and power adapter through the pedestal. Feed the cords from the bottom and have them exit through the top.
4. Connect the ground cord, foot plate cable, Ethernet cable and power adapter to the SmartLog Pro®. Set its power switch to the ON position.
5. Connect the SmartLog Pro to the mounting bracket, and secure it using its included thumbscrew.

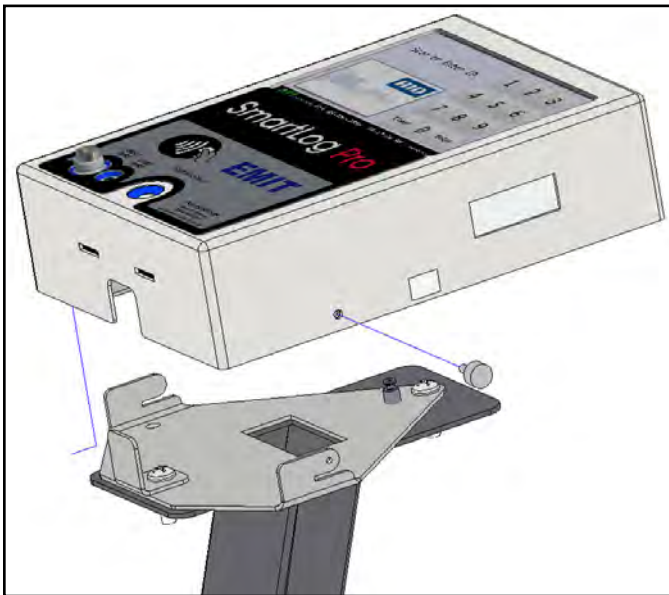

Figure 4. Securing the SmartLog Pro® to its mounting bracket



Figure 5. Final assembly of the SmartLog Pro® on the pedestal

6. Connect the ground cord's ring terminal to a known ground point. Connect the foot plate cable to the foot plate. Verify that the Ethernet cable is connected to your network.
7. Lay the dual foot plate onto the base plate.

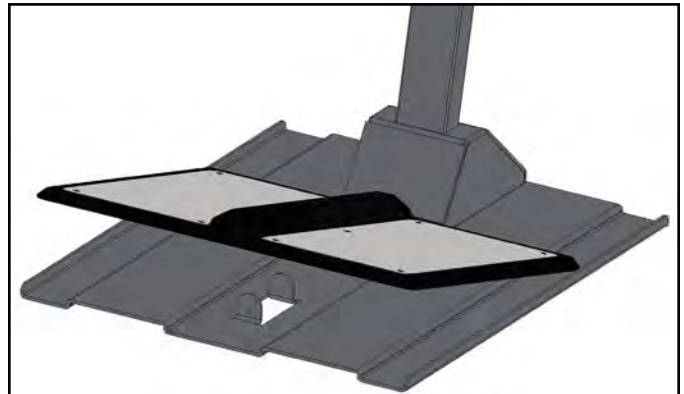

Figure 6. Installing the dual foot plate onto the baseplate

8. Connect the power adapter to an appropriate power outlet to power the SmartLog Pro®. The display will turn on, and the boot sequence will initiate. "Scan or Enter ID" will display on the SmartLog Pro® after the boot sequence has completed. The blue LEDs will continuously cycle around the test switch when the ESD tester is on standby.



Figure 7. Completed assembly of the SmartLog Pro® and 50416 Stand

## Maintenance

To maintain optimum performance, cleaning should be performed on a regular basis. Use a minimum of 80% Isopropyl alcohol to clean the foot plate and test switch of the SmartLog Pro®. Other cleaners are susceptible to leaving residue on these surfaces.

## Specifications

|                   |  |
|-------------------|--|
| Dimensions        | 19.0" x 15.5" x 38.0"<br>(48 cm x 39 cm x 97 cm) |
| Weight            | 23 lbs (10.4 kg)                                 |
| Construction      | Grey powder-coated steel                         |
| Country of Origin | United States of America                         |

### Limited Warranty, Warranty Exclusions, Limit of Liability and RMA Request Instructions

See the EMIT Warranty -