

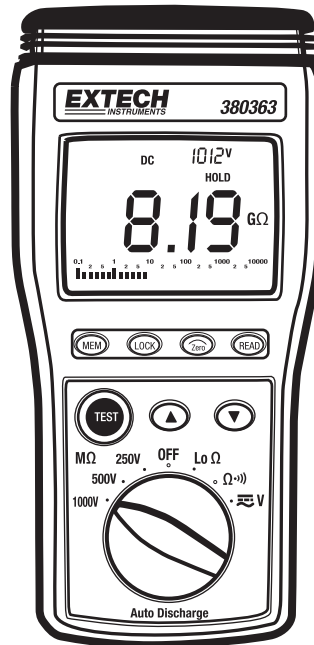

User Manual

Model 380363 Insulation Tester / Megohmmeter



Introduction

Congratulations on your purchase of Extech's Insulation Tester/Megohmmeter. The Model 380363 provides three test ranges plus continuity and AC/DC voltage measurement. Manual datalogging stores up to 9 data sets. This professional meter, with proper care, will provide years of reliable service.

Safety

1. Circuits under test must be de-energized and isolated before connections are made (except for voltage measurements).
2. Circuit connections must not be touched during a test. Use extreme caution when working near bare conductors and bus bars. Accidental contact with conductors could result in electrical shock.
3. Use caution when working near voltages above 60VDC or 30VACrms.
4. After insulation tests, capacitors must be discharged.
5. Test leads (including alligator clips) must be in good working order, clean and without broken or cracked insulation.
6. When servicing, use only specified replacement parts.

International Safety Symbols



Caution, refer to this manual before using this meter



Dangerous Voltages



Meter is protected throughout by double or reinforced insulation

Meter Description

1. LCD Display
2. LOCK button
3. MEMORY control button
4. UP arrow key
5. TEST button
6. Rotary switch
7. DOWN arrow key
8. READ memory button
9. ZERO adjust button
10. Input terminals

The tilt stand and battery compartment are located at the rear of the instrument

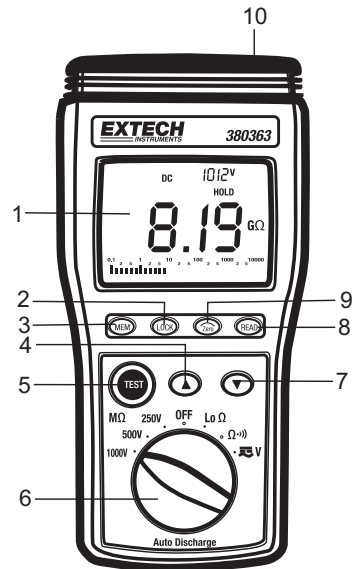

Operation

Connecting Test Leads

Warning

Ensure that the circuit under test does not include components that can be damaged by 1000VDC; such devices include power factor correction capacitors, low voltage mineral insulated cables, electronic light dimmers, and ballasts/starters for fluorescent lamps.

For all measurements connect the red test lead to the VΩ input terminal and the black test lead to the COM input terminal.

Test Lead Check

1. Set the rotary switch to the Ω range.
2. Touch the test lead tips together.
3. Resistance should read less than 0.5Ω and the audio tone should sound.
4. With the leads not touching, the display should read OL indicating over-range.
5. Readings displayed other than the readings described above are evidence of a problem and the test leads must be replaced before using the meter. Failure to do so could result in damage to equipment and electrical shock. If replacing the test leads does not solve the problem, return the instrument for repair.

Insulation Resistance Measurements (Megohmmeter Tests)

Warning: Do not perform Insulation Resistance measurements if AC Voltage is present on the device under test.

1. Connect the red test lead to the $V\Omega$ input terminal; black lead to the COM terminal.
2. Set the function switch to the desired $M\Omega$ test voltage position.
3. Connect the tips of the test leads to the equipment under test. If there is a voltage present, it will be displayed. A repetitive beep and the flashing high voltage symbol  will be displayed if the voltage is over 30V.
4. The display will show "----" until the TEST button is pushed. Press and hold the TEST button. The upper right display shows the test voltage applied. The main display shows the resistance. If the display reads OL, the measurement is beyond the range of the instrument.
5. Keep the test leads connected to the equipment under test and release the TEST button. The circuit will discharge through the meter. Keep the test leads connected until the circuit is completely discharged and the upper right display shows 0 volts.

Test Lock Function

For hands-free operation, use the TEST LOCK feature.

1. With the test leads connected to the equipment under test, press the LOCK key to enter the LOCK mode. The LOCK icon  will appear on the display.
2. Press the TEST key to start the test. A beeper will sound every 2 seconds to indicate that the meter is in Lock mode.
3. Press LOCK or TEST to disable the Lock function and end the test.

Notes on IR (Megohmmeter) testing:

1. The maximum measurement range for the 380363 is 10G Ω . Frequently, insulation resistance will exceed this value and the meter will show the overload display symbol OL, indicating that the insulation under test is good.
2. If the device being tested is highly capacitive, the display will indicate an increasing resistance value over time. Allow the reading to stabilize before ending a test.

Manual Data Store and Read Mode

To Clear Memory

1. Turn the meter off.
2. Press and hold down the MEM key, and turn the meter on.
3. The display will show "MEM", "X", "CLr" and "no".
4. Press " \rightarrow " to select "yes" to erase or "no" to leave.
5. If "yes" was selected, press "MEM" to erase the memory.

Entering data into memory

1. Press the MEM key to enter the displayed data into memory.
2. The display will show "MEM" and the memory address number in the upper left hand corner. Total memory size is 9 sets.
3. When the memory is full, the LCD will show "MEM F".

Reading memory data

1. Press the READ key to enter Read Mode. The display will show the "READ" icon and the memory address number in the upper left hand corner.
2. Use the \blacktriangle and \blacktriangledown arrow keys to scroll through the stored readings.
3. Press the READ key again to exit this mode.

AC/DC Voltage Measurement

1. Set the Rotary switch to the $\overline{\sim}$ V position.
2. Connect the red test lead to the V Ω terminal and the black test lead to the COM terminal.
3. Connect the test leads to the circuit under test.
4. Read the voltage value on the LCD. The meter shows DC voltage in the upper right and AC voltage on the main display.



Resistance Measurement and Audible Continuity Test

WARNING

Do not run this test unless ACV = 0. Do not use this mode to check diodes.

1. Set the Rotary switch to the Ω  position.
2. Connect the red test lead to the V Ω terminal and the black lead to the COM terminal.
3. Connect the tips of the test leads to the circuit under test.
4. Read the resistance value on the display. When the resistance of a circuit is less than approx. $100\Omega \pm 80\Omega$, the audible tone will sound.

LO Ω Low Resistance Measurement

1. Set the Rotary switch to the Lo Ω position.
2. Connect the red test lead to the V Ω terminal and the black lead to the COM terminal.
3. Touch the test leads together and press the  key to zero the display.
4. Connect the probes to the circuit under test. If there is a voltage present, it will be displayed. A repetitive beep and the flashing high voltage symbol  will be displayed if the voltage is over 30V. Remove the voltage before proceeding to the next step.
5. Press and hold the TEST key until a stable reading is displayed.
6. Release the TEST key. The upper right hand display will hold the reading until a new test is started or a different function is selected.
7. Swap the red and black probes to reverse the polarity of the test current. The reading should remain the same. This test is useful to detect corroded connections which can cause different readings in both polarities.

Using the LOCK Function to measure resistance

The Lock function can be used to make several resistance measurements in succession without the need to push and hold the TEST key for each measurement.

1. Press the LOCK key to enter the LOCK mode, and then press the TEST key.
2. Zero out the test lead resistance.
3. Connect the probes to the test locations in succession.
4. Press the LOCK key to disable the lock function.

Note: The meter cannot indicate if the circuit is live in this mode. Ensure that the circuit is de-energized before connecting the test leads or the fuse may blow.

Auto Power Off

To conserve battery life, the meter will automatically turn off after 15 minutes of non-use. To turn the meter back on, turn the rotary switch to OFF, then to the desired function.

Analog Bar Graph

The analog bar graph displays resistance on a logarithmic scale and voltage on a linear scale. The value always tracks the main display.

Maintenance

Battery Replacement

When the low battery symbol appears (BT) on the LCD the six 1.5V 'AA' batteries must be replaced.

1. Turn the meter off and remove the test leads
2. Remove the two (2) Phillips head screws on the rear of the meter
3. Remove the meter's rear cover
4. Replace the batteries observing polarity
5. Affix the rear cover and secure the rear screws



You, as the end user, are legally bound (**Battery ordinance**) to return all used batteries and accumulators; **disposal in the household garbage is prohibited!**

You can hand over your used batteries / accumulators at collection points in your community or wherever batteries / accumulators are sold!

Disposal: Follow the valid legal stipulations in respect of the disposal of the device at the end of its lifecycle

Fuse Replacement

If the meter turns ON but does not measure correctly, check the internal fuse.

1. Turn the meter off and remove the test leads
2. Remove the four (4) Phillips head screws on the rear of the meter
3. Remove the meter's rear cover
4. Check and replace the fuse if necessary (0.5A / 600V fast blow)
5. Affix the rear cover and secure the rear screws

Cleaning

Periodically wipe the case with a dry cloth. Do not use solvents or abrasives to clean this instrument.

Applications

Measuring Power Tools and Small Appliances

This section applies to any device under test that uses a line cord. For double insulated power tools, the meter's leads should be connected to the device's housing (chuck, blade, etc.) and to the lines of the power cord. Refer to the diagram.

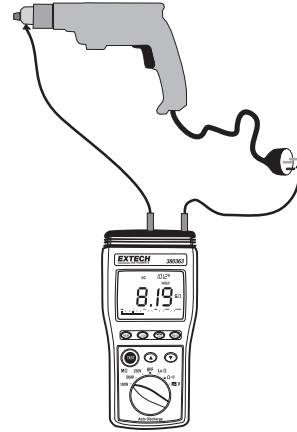

Testing AC Motors

Disconnect the motor from the line by disconnecting the wires from the motor terminals or opening the mains switch.

If the mains switch is opened, and the motor also has a motor-starter, then the starter must be held in the ON position. With the mains switch opened, the measured resistance will include the resistance of the motor wire and all other components between the motor and the main switch. If a weakness is indicated, the motor and other components should be checked individually. If the motor is disconnected at the motor terminals, connect one meter lead to the grounded motor housing and the other lead to one of the motor leads. Refer to diagram at below.

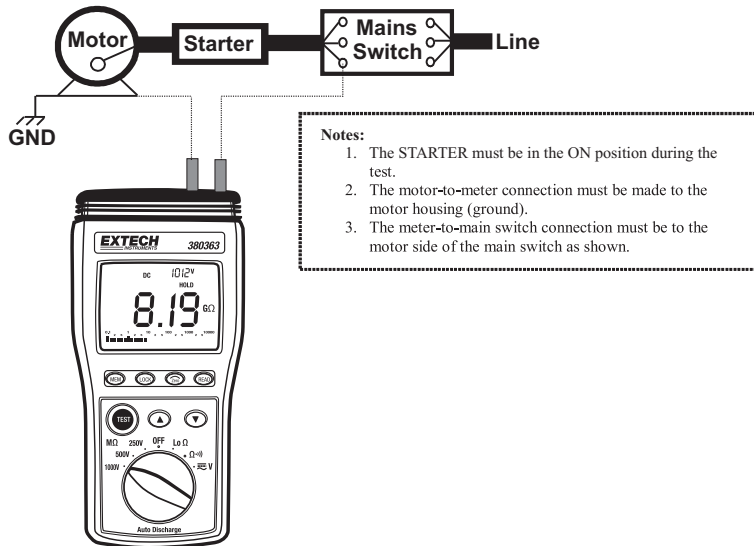

Testing DC Motors

1. Disconnect the motor from the line.
2. To test the brush rigging, field coils and armature, connect one meter lead to the grounded motor housing and the other lead to the brush on the commutator.
3. If the resistance measurement indicates a weakness, raise the brushes off of the commutator and separately test the armature, field coils and brush rigging (one at a time). Leave one lead connected to the grounded motor housing while testing the motor components. This also applies to DC Generators.

Testing Cables

1. Disconnect the cable under test from the line.
2. Disconnect the opposite end of the cable to avoid errors as a result of leakage from other equipment.
3. Check each conductor to ground and/or lead sheath by connecting one meter lead to ground and/or lead sheath and the other meter lead to each of the conductors in turn.
4. Check insulation resistance between conductors by connecting meter leads to conductors in pairs. Refer to diagram. In the diagram, note that the 3-conductor cable has two wires shorted to the ground shield. This two-wire/shield connection is then connected to one side of the meter. The remaining conductor is connected to the other side of the meter.



Specifications

General specifications

Display	3-3/4 digit (4000 count) LCD
Sampling rate	1 reading per second
Test ranges	Resistance: 4M Ω , 40M Ω , 400M Ω , 4000M Ω , 10G Ω Test Voltages: 250V, 500V, 1000V
AC/DC Voltage range	999V
Resistance range	9999 Ω
Lo Resistance range	40 Ω
Over range indicator	'OL' displayed when measurement exceeds range
Zero adjust	Automatic
Memory	Nine (9) data records
Low battery indicator	'BT' symbol displayed when battery voltage is low
Power source	Six (6) 1.5 'AA' batteries
Power consumption	20 to 95mA (depending upon function)
Fuse protection	0.5A / 600V fast blow fuse
Operating conditions	32 to 122°F (0 to 50°C); 80% RH
Dimensions	9.3 x 4.6 x 2.1" (235 x 116 x 54mm)
Weight	1.15 lbs (520g)
Safety ratings	Pollution degree 2; indoor use; CE marked; Meets IEC 61010-1 and IEC 61557 standards
Category Rating	CAT III-1000V, CAT IV-600V

Range Specifications

MEGOHMMETER RANGES

Range	Test Voltages	Resolution	Accuracy
4M Ω	250V (+30% ~ -0%) 500V (+30% ~ -0%) 1000V (+30% ~ -0%)	0.001M Ω	3%+5 (<1000M)
40M Ω		0.01M Ω	
400M Ω		0.1M Ω	5%+5 (>1000M) (% reading + digits at 23°C \pm 5°C < 80% RH)
4000M Ω		1M Ω	
10G Ω		00.01G Ω	
Analog Bar Graph	0 to 10G Ω		
Nominal Current	\geq 1mA		
Circuit Protection	Test inhibited if input \geq 30V AC or DC		

AC VOLTAGE (40Hz-500Hz)

Range	Res.	Accuracy	Input impedance	Overload Protection
999VAC	1V	\pm 2% + 2d	9M Ω	1000Vrms

DC VOLTAGE

Range	Res.	Accuracy	Input impedance	Overload Protection
999VDC	1V	\pm 1% + 2d	9M Ω	1000Vrms

RESISTANCE & CONTINUITY

Range	Res.	Accuracy	Max. open circuit Volt	Overload Protect.
Resistance: 999.9 Ω	0.1 Ω	\pm 1% + 3d	3V	1000Vrms
Continuity	100 Ω \pm 80 Ω)			

LOW RESISTANCE Ω

Range	Res.	Accuracy	Max. open circuit Volt	Overload Protection
40 Ω	0.01 Ω	\pm 2% + 2d	6V	>30V AC/DC