

300S SERIES

Continuous Submersible Level Transmitter



- Works on Foam | Vapor | Turbulence
- Excellent Chemical Resistance
- 316L SS
- Teflon® Jacketed Cable
- High Accuracy

316 SS

FFKM

PTFE

SERIES : 316SS
BODY : 316L SS
O-Ring SEALS : FFKM



The 300S Series Transmitter is designed for Continuous Level Measurement of Aggressive Liquid Media

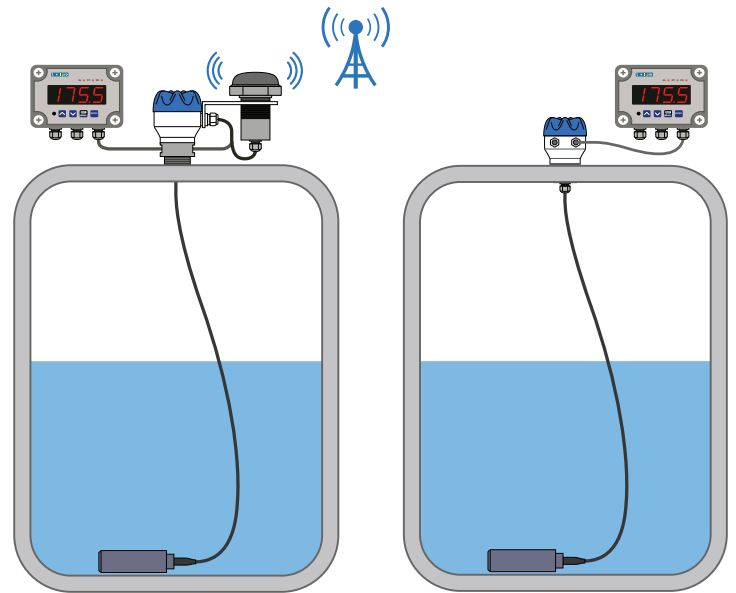

Pressure Measurement

- ▶ Tanks | Sumps > 100 ft Range

Output Signal

- ▶ 4-20mA | 0.5-4.5 | 0.5-4.5
Ratiometric | RS485

Features

- ▶ Acids | Bases
- ▶ 316L SS Sensing Diaphragm
- ▶ High Accuracy
- ▶ Non Clogging Design
- ▶ PTFE Teflon® Jacketed Cable or PUR Cable
- ▶ Excellent for Foam | Vapor | Condensate
- ▶ Heavy Duty Rugged Design
- ▶ No Moving Parts
- ▶ Automatic Temperature Compensation

Applications



- Foam | Vapor | Turbulence | Condensate
- Waste Water Treatment
- Leachate Collection
- Waste Sumps or Pits
- Chemical Dosing
- Inventory Management



- Acids + Bases
 - Bulk Chemicals
 - Chemical Day Tanks
 - Plating Tanks
 - PH Control Tanks
 - Storage Tank Monitoring
- ▶ **The Solution to Tough Applications where Ultrasonic Sensors Simply DO NOT WORK!**
 - ▶ **No Lost Signals**

300S SERIES

Continuous Submersible Level Transmitter



Input Pressure Range

Level M/H ₂ O		2	5	10	X	* Consult Factory for Levels > 10M
Overpressure	psi	210	290	210		
Burst Pressure >	psi	290	580	290		

Output Signal

Unit Dependant	4-20mA 0.5-4.5VDC Ratiometric 0.5-4.5VDC RS 485 HART
----------------	--

Power Supply

DC Power Only	4-20mA } 24 VDC 0.5-4.5VDC Ratiometric 0.5-4.5VDC } 5VDC RS 485 HART } 24VDC
---------------	---

Performance

Accuracy ¹	Standard Nominal Pressure > 5.8 psi $\leq \pm 0.5\%$ FSO IEC 60770 2:
Permissible load	Current 2-wire $R_{max} = [(V_S - V_{S\ min}) / 0.02\ A] \Omega$ Voltage 3-wire $R_{min} = 10\ k\Omega$
Influence effects	Supply 0.05 % FSO / 10 V Load 0.05 % FSO / $k\Omega$
Long term stability	$< \pm 0.1\%$ FSO / year
Response time	< 10 msec

¹Test standard: GB/T28474 | IEC60770 | Linear output, Zero(0) based-calibration span | Limit Point Adjustment | Non-Linearity | Hysteresis | Repeatability. The overall performance of the 300S including but not limited to environmental temperature, comprehensive error and reference accuracy

Thermal Effects | Offset and Span

Thermal Error	$< \pm 0.2\%$ FSO/K in Compensated Range -13° F - 178° F -25°C - 85°C
---------------	--

Permissible Temperatures

Permissible Temperatures	Media -40°F to 178°F -40 - 85°C Storage -40°F to 178°F -40°C - 85°C
--------------------------	--

Electrical Protection

Short-Circuit Protection	Permanent
Reverse Polarity Protection	No Damage to Sensor } No Function
Electromagnetic Compatibility	Emmison Immunity According to EN 61326
Power Supply	24VDC 5VDC

Electrical Connection

Jacketed Cable	PTFE Teflon® -40 - 200°F
----------------	----------------------------

cable capacitance: signal line/shield also signal line/signal line: 160 pF/m cable inductance:signal line/shield also signal line/signal line: 1 μ H/m
3 or 4 Wire Cable with Integrated Air Tube for Atmospheric Pressure Reference

Materials | Wetted

Housing	316L
Diaphragm Seal	Welded 316L
Diaphragm	316L

300S SERIES

Continuous Submersible Level Transmitter



Miscellaneous

Current Consumption	Max. 25mA
Weight	Approx. 280g Cable Not Included
Ingress Protection	IP68
CE-Conformity	EMC Directive I 2004/130/EU Pressure Equipment Directive I 2014/168 EU
ATEX Directive**	* Option - PTB97 ATEX 1068 U
Operational Life	> 100 million load cycles @ 77°F 25°C
Current Consumption	Signal Output Current max 25mA Signal Output Voltage max 7mA

Wiring Diagram

Per IEC 61298-3|GB/T1827.3 | 20g | Maximum Vibration Value < 3mm | 5-2000HZ

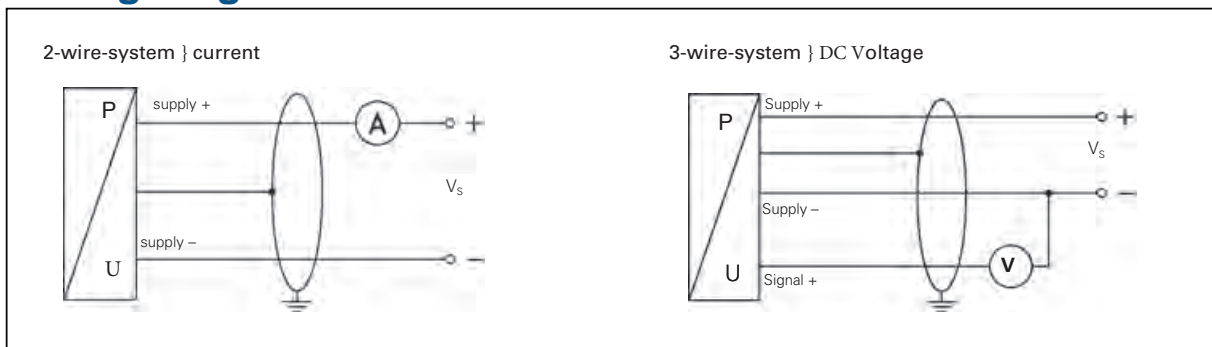

Ordering Code 300S Series

Pressure																				
M/H2O	3	0	0	S																
Level	M/H20																			
	2.0	1	0	0	2															
	5.0	1	0	0	5															
	10.0	1	0	1	0															
	X	1	X	X	X															
Output Signal																				
	4-20mA					A														
	0.5-4.5VDC Ratiometric					R														
	0.5-4.5VDC					V														
	RS485 HART					RS														
Cable Length*																				
	3																			
	6.0																			
	11.0																			
	X																			

DC Power Only

