

Airius – Wireless vibration sensor

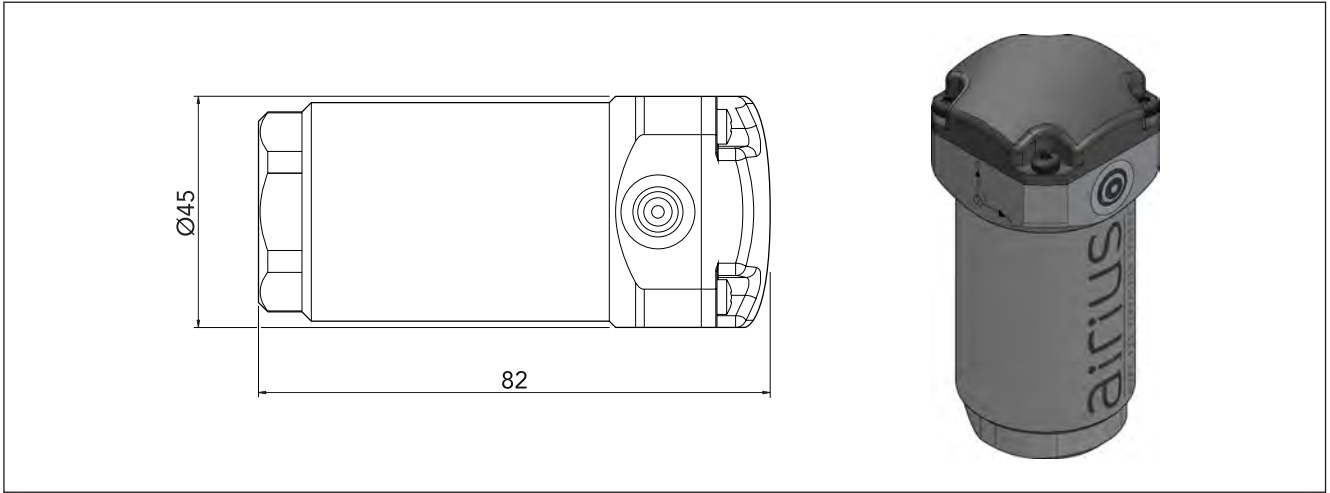

Airius is a wireless, battery-powered sensor that performs a user-defined number of vibration measurements per day in the 10-1000 Hz or the 2-1000/10-5000 Hz frequency range. The MEMS (micro-electro-mechanical-systems) type sensor with digital output measures triaxial vibration and temperature.

The vibration sensor is optimal for use on standard production equipment, such as pumps and fans. Airius provides warning of vibration-related problems, such as imbalance, misalignment, impeller and fan blade issues, resonance, and cavitation, as well as gear and bearing faults. The sensor is ideal wherever wireless transmission of vibration data is practical or a matter of safety, as in inaccessible machines or machines placed in hostile or risky environments.

The favorable choice of battery technology, along with the careful design, ensure four-year battery life at four measurements a day under ideal conditions.

Airius is compatible with both Condmaster.NET, the cloud-based application providing easy access to measurement data through a user-friendly interface, and the analysis and diagnostic software Condmaster Ruby.

The SPM Connect app, downloadable for mobile devices, is used to configure the parameters required to connect to Condmaster Entity Server (CES) or SPM Cloud. The app allows you to

- search for Airius vibration sensors via Bluetooth
- verify server connection
- set up connection to Wi-Fi and CES/SPM Cloud.

Technical specifications

Material:	housing; stainless steel 316L, cover; polyamide
Weight:	approx. 300 g
Power supply:	non-rechargeable 3.6 VDC Lithium
Frequency range:	10-1000 Hz or 2-1000/10-5000 Hz
Readings:	RMS, peak, peak-to-peak, crest, kurt, skew, temperature
Measurement range, temperature:	-40° to +85 °C (-40° to +185 °F) (accuracy +/- 2 °C)
Spectrum lines:	400, 800, 1600 lines

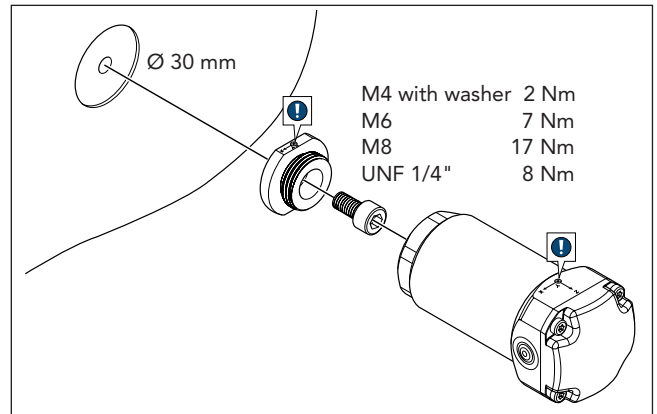

Operating temperature:	-20° to +85 °C (-4° to +185 °F)
Storage temperature:	-40° to +120 °C (-40° to +248 °F)
Maximum altitude:	2000 m
Condition evaluation:	ISO10816 Part 2, 3, 4 >600 rpm
Protection class:	IP69
Relative humidity:	0 to 100% (non-condensing)
Wi-Fi:	802.11 b/g/n, 2.4 GHz
Wi-Fi Security:	WPA/WPA2 PSK/WPA2 Enterprise (PEAP-MSCHAPv2 and TTLS-MSCHAPv2 without certificates)
Bluetooth:	v4.2 BLE

Part numbers

- AIR01-01 Airius vibration sensor, 10-1000 Hz
- AIR01-10 Airius vibration sensor, 2-1000 Hz and 10-5000 Hz

Accessories

- 18470 Installation kit (installation foot, M4 screw, M4 washer, M6 screw)
- 18471 Installation kit (installation foot, M8 screw)

Spare parts

- 18472 Cover kit (cover, gasket, 4xM3 screws)
- 18477 Battery cell Airius, Xeno

SPM

1.800.561.8187

www.itm.com

information@itm.com

© 2014 ITM. All rights reserved. ITM is a registered trademark of ITM. All other trademarks are the property of their respective owners.