

SHARK[®] 50B/100B

BACnet Communicating Multifunction Power Meters



Shark[®] 100B Power Meter/Transducer
The Shark[®] 100B also offers a Transducer only option.

Shark[®] 50B Power Meter/Transducer

Features

- Multifunction Measurements of Voltage, Current, Power and Energy
- Industry Recognized Superior 0.2% (100B)/0.5% (50B) Energy Class Accuracy
- BACnet/IP and Modbus TCP/IP Ethernet (100B); BACnet MS/TP Serial and Modbus TCP/IP Ethernet (50B)
- Available in Meter or Transducer Version (100BT)
- Highly Reliable Industrial Rated Design

Introduction

Electro Industries introduces our industry-leading revenue grade power meter with native BACnet protocol. This meter is designed to integrate seamlessly into existing and new building management systems that use BACnet. Available as either a meter or a transducer (100BT), the unit allows you to gather data on voltage, current, power, and energy usage throughout a facility.

The Shark[®] 50B/100B was designed to be the perfect device for “green” initiatives, LEED certified projects, smart buildings, and other smart energy projects. The Shark[®] 50B/100B’s metrology is industry recognized as superior, providing revenue testable

0.2% (100B)/5% (50B) energy accuracy with compliance to modern ANSI and IEC accuracy standards. The unit utilizes advanced DSP technology, high sampling rates, and 24-bit analog to digital conversion to measure and analyze power accurately and reliably.

Applications

- LEED Projects
- Alternative Energy Monitoring
- Commercial Energy Management
- HVAC Efficiency Monitoring
- Building Management Systems

Bi-directional, Highly Accurate Energy Measurements Perfect for Alternative Energy



1.800.561.8187

www.itm.com

information@itm.com

Shark® 50B/100B with BACnet: the “Green” Choice

The Shark® 50B/100B meter with BACnet MS/TP or BACnet/IP supports building energy management strategies, LEED certification and other green building initiatives. By letting you track energy use and power quality from wherever you are, the meter gives you the information you need to accurately identify cost saving measures and respond to power quality problems when they arise. The meter’s readings can also be viewed and analyzed using CommunicatorPQA® software, which lets you program the meter and view real time readings remotely.

Additional Features Include:

- **100B:** BACnet/IP, Modbus TCP/IP, IrDA
- **50B:** BACnet MS/TP, Modbus TCP/IP

Both meters support an embedded web server.



BACnet Objects			
Volts A-N	VARh Net	Positive Watts, 3-Phase, Average Demand	Volts, A-N THD*
Volts B-N	kVARh Net	Positive kWatts, 3-Phase, Average Demand	Volts, B-N THD*
Volts C-N	Frequency	Positive VARS, 3-Phase, Average Demand	Volts, C-N THD*
Volts A-B	Neutral Current	Positive kVARS, 3-Phase, Average Demand	Amps, A THD*
Volts B-C	Whr Received	Negative Watts, 3-Phase, Average Demand	Amps, B THD*
Volts C-A	kWhr Received	Negative kWatts, 3-Phase, Average Demand	Amps, C THD*
Amps A	Whr Delivered	Negative VARS, 3-Phase, Average Demand	
Amps B	kWhr Delivered	Negative kVARS, 3-Phase, Average Demand	
Amps C	Whr Net	Positive VARS, 3-Phase, Max Average Demand	
Total Watts	kWhr Net	Positive kVARS, 3-Phase, Max Average Demand	
Total kWatts	Total Whr	Negative Watts, 3-Phase, Max Average Demand	
Total VARS	Total kWhr	Negative kWatts, 3-Phase, Max Average Demand	
Total kVARS	Positive VARh	Negative VARS, 3-Phase, Max Average Demand	
Total VA	Positive kVARh	Negative kVARS, 3-Phase, Max Average Demand	
Total kVA	Negative VARh	Positive Watts, 3-Phase, Max Average Demand	
Total PF	Negative kVARh	Positive kWatts, 3-Phase, Max Average Demand	
Total VAh		VAs, 3-Phase, Average Demand	
Total kVAh		kVAs, 3-Phase, Average Demand	
Total VARh		VAs, 3-Phase, Max Average Demand	
Total kVARh			

Pre-defined objects in the Shark® meters' BACnet protocol. *These values are only for the 100B meter.

Shark® 50B/100B BACnet Through the Web

The Shark® 50B/100B meter’s BACnet comes standard with a web interface. Use the interface to remotely set up the BACnet configuration and track energy usage through the Internet with any standard web browser. You do not need to be on-site; you can check on your buildings from anywhere in the world! There is also a Modbus TCP/IP socket that can be used to simultaneously poll Modbus TCP/IP through the same device.

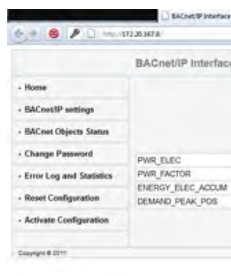

Measured Parameters	Accuracy % of Reading		Display Range
	100B	50B	
Voltage L-N	0.1%	0.2%	0-9999 Scalable V or kV
Voltage L-L	0.1%	0.4%	0-9999 V or kV Scalable
Current	0.1%	0.2%	0-9999 A or kA
+/- Watts	0.2%	0.5%	0-9999 Watts, kWatts, MWatts
+/- Wh	0.2%	0.5%	5 to 8 Digits Programmable
+/- VARs	1.0%	same	0-9999 VARs, kVARs, MVARs
+/- VARh	1.0%	same	5 to 8 Digits Programmable
VA	1.0%	same	0-9999 VA, kVA, MVA
VAh	1.0%	same	5 to 8 Digits Programmable
PF	0.2%	1.0%	+/- 0.2 to 1.0
Frequency	+/- 0.01 Hz	same	45 to 65 Hz
THD	5.0%	N/A	0 to 100%
Load Bar	1-120%	same	10 Digit Resolution Scalable

Note: Typical results are more accurate. Applies to 3 Element WYE and 2 Element Delta Connections. Add 0.1% of Full Scale plus 1 digit to Accuracy specs for 2.5 Element connections.

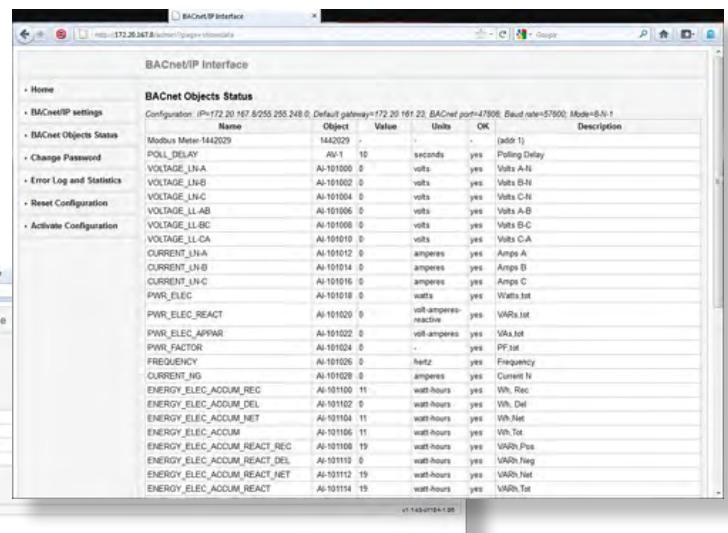

Wiring Diagrams

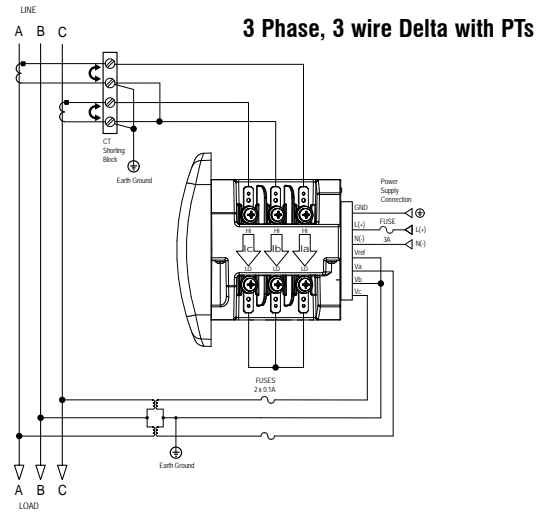
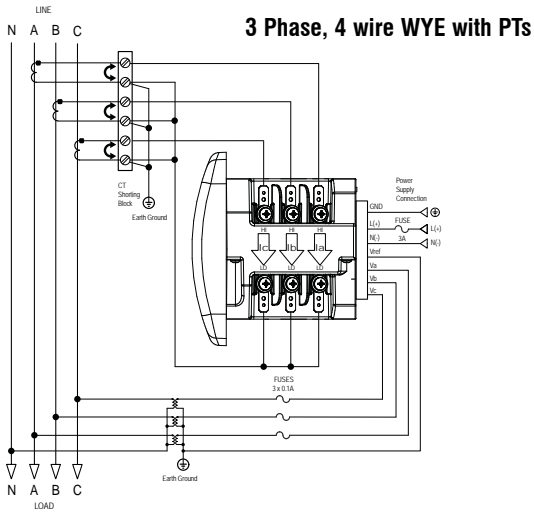
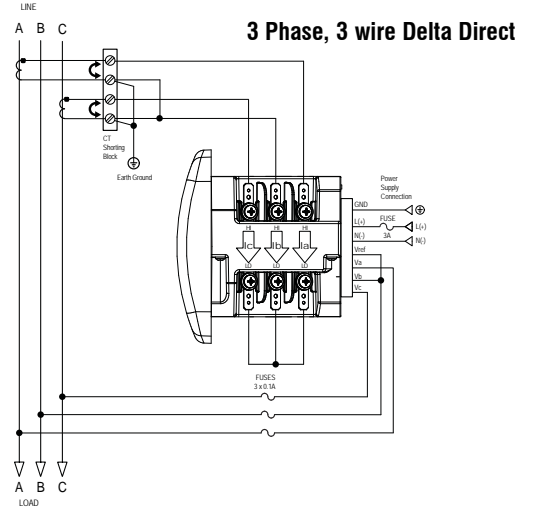
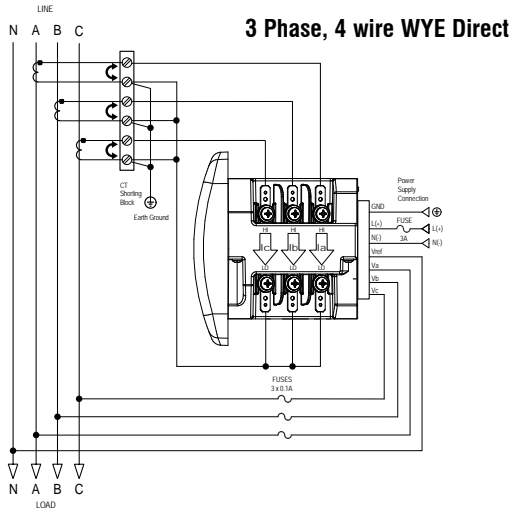

Dimensional Drawings

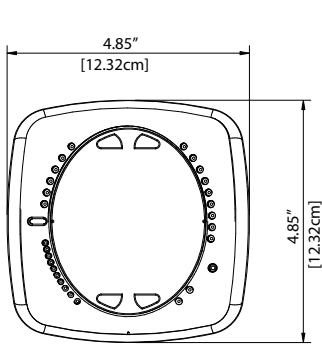

Front View

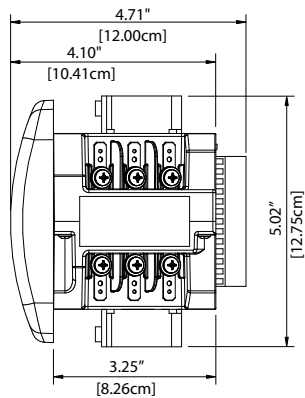

Side View

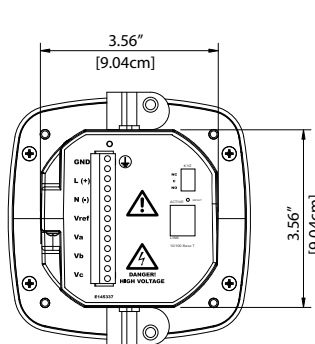

Rear View

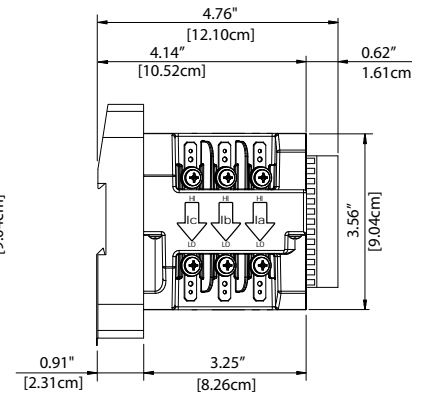

Transducer

Specifications

Voltage Inputs

- Absolute Range: (20-416) Volts Line to Neutral, (0-721) Volts Line to Line
- Universal Voltage Input
- Input Withstand Capability – Meets IEEE C37.90.1 (Surge Withstand Capability)
- Programmable Voltage Range to Any PT Ratio
- Supports: 3 Element WYE, 2.5 Element WYE, 2 Element Delta, 4 wire Delta systems
- Burden: 0.36 VA per phase max at 600 V, 0.014 VA at 120 V
- Input wire gauge max (AWG 12 / 2.5 mm²)

Current Inputs

- Class 10: (0.005 to 10) A, 5 A Nominal CT Secondary
- Class 2: (0.001 to 2) A, 1A Nominal CT Secondary
- Fault Current Withstand (at 23 °C): 100 A for 10 Seconds, 300 A for 3 Seconds, 500 A for 1 Second
- Programmable Current to Any CT Ratio

- Burden 0.005 VA per phase max at 11 A
- 5 mA Pickup Current
- Pass through wire gauge dimension: 0.177" / 4.5 mm
- Continuous current withstand: 20 A for screw terminated or pass through current connections

Isolation

All Inputs and Outputs are galvanically isolated to 2500 V AC.

Environmental Rating

- Storage: (-20 to +70) °C
- Operating: (-20 to +70) °C
- Humidity: to 95% RH Non-Condensing
- Faceplate Rating: NEMA12 (Water Resistant)
- Mounting Gasket Included
- Protection: IP30 - Meter Front/Back, Optional DIN Rail Mounting

Sensing Method

- RMS

- Sampling at 400+ samples per cycle on all channels measured readings simultaneously
- Harmonic THD (% of Total Harmonic Distortion - 100B)

Update Rate

- Watts, VAR, and VA-100 ms (100B only)
- All other parameters-1 second

Power Supply

Option D2:

- (90 to 265) V AC and (100 to 370) V DC Universal AC/DC Supply

Option D (100B Only):

- (18-60) V DC

Burden: 10 VA Max

Communication Format

- 2 Com Ports (Back and Faceplate)
- BACnet / IP (100B); BACnet MS/TP (50B)
- IrDA (through Faceplate)
- Modbus TCP/IP
- Baud Rate: 57.6k baud

KYZ Pulse

- Type Form A

- On Resistance: (25-35) Ohm
- Peak Voltage: 350 V DC
- Continuous Load Current: 120 mA
- Peak Load Current: 350 mA (10 ms)
- Off State Leakage Current @ 350 V DC: 1 mA
- Opto-Isolation: 3750 V AC (60 Hz, 1min)

Dimensions and Shipping

- Weight: 2 lbs
- Basic Unit: (H4.85 x W4.85 x L4.25) in.
- Shark® 50B/100B – mounts in 96 mm DIN and ANSI C39.1 4" round cutouts
- Shark® 100BT-DIN rail mounted transducer
- Shipping Container Dimensions: 6" cube

Meter Accuracy

- See page 2

Compliance:

- ANSI C12.20-2010 Accuracy, Class 0.2 CL - 100B; 0.5 CL - 50B
- IEC 62053-22 Accuracy, Class 0.2S-100B; 0.5S-50B *

- IEC 62053-23 Edition 1 Class 2
 - CE (IEC 61000-6-2 & IEC 61000-6-4 & IEC 61326-1)*
 - IEC 61000-4-2 (Electrostatic Discharge)*
 - IEC 61000-4-3 (Radiated EM Immunity)*
 - IEC 61000-4-4 (EFT)*
 - IEC 61000-4-5 (Surge Immunity)*
 - IEC 61000-4-6 (Conducted Immunity)*
 - IEC 61000-4-8 (Magnetic Immunity)*
 - IEC 61000-4-11 (Voltage Variations Immunity)*
 - IEC/CISPR 11, Class A (Conducted, Radiated Emissions)*
 - IEEE C37.90.1 (Surge Withstand)
 - IEEE C62.41 (Surge Immunity)
 - EU Directive 2011/65/EU (RoHS 3 Directive)
 - REACH Compliant
 - Certified to UL 61010-1 and CSA C22.2 No. 61010-1, UL File: E250818
- * Third party lab tested

Ordering Information: To order, please fill out ordering guide:

Model	Frequency	Current Class	Power Supply	Mounting (Shark100B Only)
Option Numbers:	-	-	-	-
Example: Shark100B	60	10	D2	X
Shark 100B (Meter/Transducer)	50 50 Hz System	10 5 A Nominal CT Secondary	D2 (90-265) V AC or (100-370) V DC	X ANSI Mounting
Shark 100BT (Transducer Only)	60 60 Hz System	2 1 A Nominal CT Secondary	D (18-60) V DC	DIN DIN Mounting Brackets (Euro Mounting)

Ordering Information: To order, please fill out ordering guide:

Model	Mounting
Option Numbers:	-
Example: Shark 50B	X
Shark 50B (Meter/Transducer)	X ANSI Mounting
	DIN DIN Mounting Brackets (Euro Mounting)

Additional Accessories

Communication Converters

CAB6490 - USB to IrDA Adapter (100B)

Contact for available CTs, shorting blocks, and fuses.

Compliance Documents

Certificate of Calibration, Part # CCal - This provides Certificate of Calibration with NISTTraceable Test Data.



1.800.561.8187

www.itm.com

information@itm.com