



**Operator's Handbook
for**



Compact
High Voltage
DC15 & DC30
POROSITY (HOLIDAY) DETECTORS

CE CE Marked PCWI Compact Detectors comply with the requirements of EMC Directives 89/336/EEC EMC and its amending directives.

CERTIFICATE OF CALIBRATION



Office: 13 Alhambra Avenue
CARDIFF NSW 2285
Newcastle - Australia
Postal: PO Box 900
HUNTER REGION MC
NSW 2310
Email: sales@pcwi.com.au
Web: www.pcwi.com.au
Phone: (02) 4954 3900
Intl: +61 2 4954 3900
Fax: (02) 4954 3999

Model : Compact Detector
Manufacturer: PCWI Technology Pty Ltd
Serial No.:
Tolerance:. ±5%

Conformance: This detector has been tested at a series of voltages from 0 to 60,000 Volts against a PCWI Certified Meter and High Voltage Probe, Report Number 213823 / Pulse Crest Meter using AS2886-1986 as a guide and complies with PCWI Standards of Manufacture.

PCWI's Laboratory has also been assessed to ISO/IEC 17025 'general requirements for the competence of testing and calibration laboratories'. All calibrations are traceable to National and International Standards.

Note: It is recommended that the unit be periodically checked prior to use with a Certified PCWI Crestmeter.

SIGNED: _____
Laboratory Technician



CONTENTS

1.0 Safety Precautions	2
2.0 Operation	3
3.0 Specifications.....	4
4.0 Control Panel Layout	5
5.0 Voltage Recommendations	6-7
6.0 Troubleshooting	8-9
7.0 Optional Accessories	10-11
8.0 Warranty	12
9.0 Service	inside back page

INTRODUCTION

Thank you for choosing the PCWI Compact for pre-installation and post installation corrosion detection.

PCWI have designed this instrument with care, to provide ongoing corrosion detection efficiency under a wide variety of coating application conditions and to ascertain Porosity for the many protective coatings currently in use. Under reasonable care in operation, the unit will provide many years of trouble free detection.

To support the unit, PCWI maintain a comprehensive range of Electrodes (probes) - extending the versatility of the Compact from large to small and from accessible to inaccessible surfaces.

PCWI, in a continuing desire to achieve the maximum in corrosion detection competence, welcomes user enquiries and recommendations.

Yours sincerely

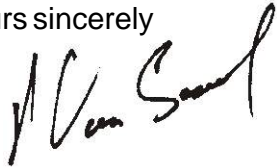

Paul Van Gaal

WARNING



This Equipment generates a high voltage and should be used with care. Please consult these operating instructions before use.

1.0 SAFETY PRECAUTIONS:



All hand-held high voltage test equipment should be operated by responsible, trained and authorised personnel.

The unit must be earthed to both the item under test and to ground.

CAUTION



The Detector output can be up to 35,000 volts. Should the operator accidentally make contact with the test electrode, they may experience a mild shock or zap, and in order to avoid this possibility, the wearing of rubber gloves is recommended.

Furthermore, the operator should enjoy good health and not suffer from a cardiac condition. **If the operator has a pacemaker, then they should not use this equipment.**

This equipment should only be used for the purpose for which it was designed, ie: checking the porosity, or electrical breakdown, of dielectric or insulating materials.

It is also recommended that testing should be carried out well clear of personnel not involved in the testing procedure, or in such a position whereby the surprise of receiving an electric shock could cause a related accident, if for example, tests being carried out close to moving or rotating machinery, or in such an unstable position that the operator could fall and injure themselves.

It is recommended that the operator should have an assistant, to ensure that unauthorised personnel are kept well clear of the testing area, and generally assist when necessary with the testing procedure. It is also recommended that the Detector not be operated within close proximity of sensitive electronic apparatus, such as computer equipment.

DANGER

Do not use the test equipment in any combustible or flammable atmosphere, as a test voltage can cause an arc or spark to be generated and an explosion could result.

Always consult the plant or safety officer before carrying out a test procedure.

When testing tank internals, be certain the tank does not contain solvents remaining from the painting procedure.

Coating Thickness Range

Applied coats should be cured, thickness tested, visually inspected and accepted – before high voltage porosity testing is carried out. Coating thickness should be above 150µm; coatings below this **thickness should be tested with a wet sponge unit.**

2.0 OPERATION

Connect the probe and earth leads to the unit. Connect the earth clamp to the metallic substrate of the item to be tested – substrate should be earthed to ground. Select the probe best suited for the test and attach to the probe handle.

Fit the Fuse (if not already fitted).

Turn the unit on.

Check the batteries to ensure that they are charged.

Turn the voltage control clockwise to the required test voltage.

Note: If the neon is in place allow an additional 200v.

Place the probe near the metal substrate.

A spark should occur (if not re-check all leads and connections).

Place the probe on the surface to be tested.

Re-check the output – adjust if necessary. Turn alarm sensitivity until the alarm is just off.

Place the probe on the coated surface and move at approximately one metre per four seconds.

A fault is indicated by:

A spark at the probe – this can usually be seen and heard.

A light flashes on the front panel of the unit.

An audible sound – buzzer is mounted inside the unit.

Digital test voltage drops drastically.

The neon in the probe flashes.

Note: A definite flaw should be made in the coating and located with the designated test voltage, therefore proving that the unit is locating the type of fault you wish to find.

Probes must be kept in full contact with the surface, gaps in or between the probe and the coating may result in flaws going undetected.

Wire brushes, rubber and coil spring probes should all be kept in good condition.

Probes other than fine wire brushes may require higher voltages.

Wet and contaminated coatings should not be tested until dry and clean (see also troubleshooting pages).

Earthing



Where the item to be tested is not earthed to ground, a ground spike **must** be attached.

The unit should always be switched off before removing and repositioning the earth lead. After the earth is repositioned, the probe should always be flashed on the substrate to prove a good contact has been made.

Leads

Carbon cored 22k High Voltage leads **must** be used.

Use of copper cored leads will void warranty.

3.0 SPECIFICATIONS

Weight:	2.2kg
Display:	LCD 3¾ digits with battery indicator
Voltage 0 to:	DC15:15kv DC30: 30kv
Resolution:	10v 10v
Short circuit:	Test current less than 0.5mA
Power supply:	3Ah Slide-off
Recharge Time:	400mA for 10hrs.
Battery Test:	When Porosity (Holiday) Detector is switched on, the result is displayed on the LCD.
Dimensions:	260 x 160 x 70mm
Alarms:	Audible – with sensitivity adjustment. Visual – front panel light. Neon in probe – 360° visibility
Probe lead:	2m carbon-cored high-voltage silicon-rubber.
Earth lead:	7m with a clamp fitted to one end.
Probes:	250mm Flat Brass Wire brush, trim length of 50mm
Carry Case:	130 x 355 x 465mm

Optional coils & brushes available: See accessories pages

STORAGE:

The Detector should be stored in a dry place. Leads should not be wound tightly. Battery should be fully charged.

4.0 CONTROL PANEL LAYOUT

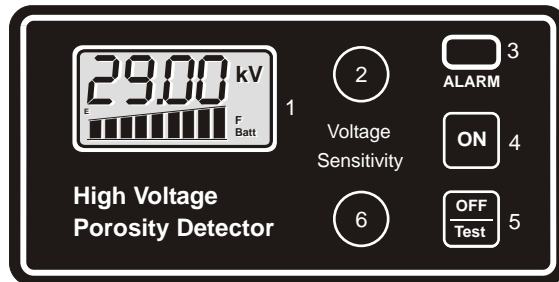

- 1 LCD display (including battery condition indicator)
- 2 Voltage control (10 turn)
- 3 Visual alarm indicates when fault is found
- 4 On switch
- 5 Off/test switch
- 6 Sensitivity control for the alarm
- 7 Audible alarm when fault is found
- 8 High Voltage probe connector
- 9 Fuse (1.6A slow blow) 5 x 20mm
- 10 Earth connection point
- 11 Charge connector – allows operation while charging is in progress
- 12 Slide-off power pack
- 13 Earphone jack

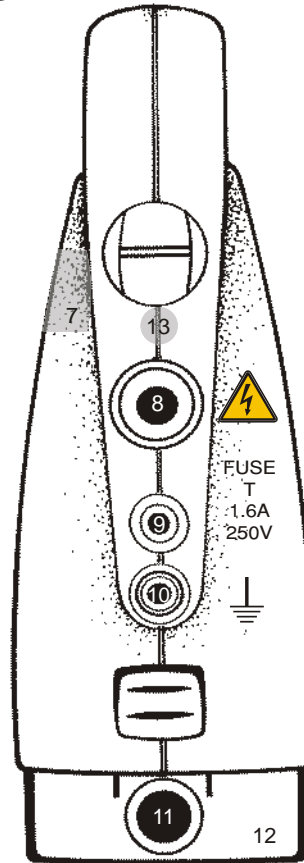

Probe Handle Diagram

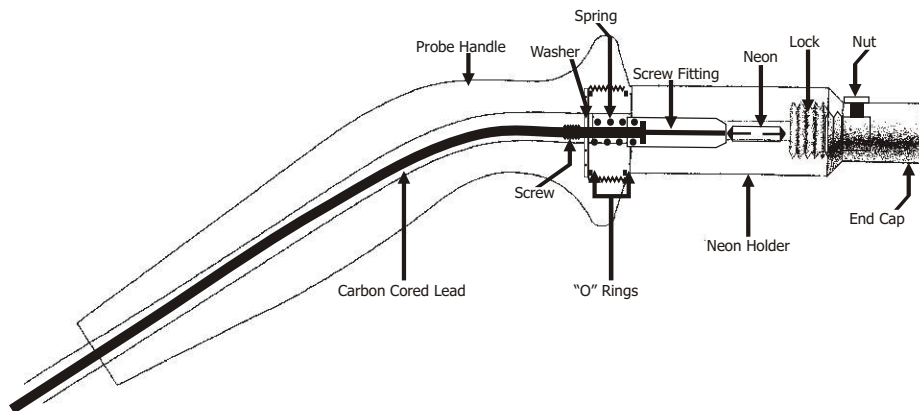

5.0 VOLTAGE RECOMMENDATIONS

AS 3894.1-2002 recommends minimum voltages for testing specified thickness of film of various Coating

Tables 1 and 2 below provide guidance for determination of minimum voltage for high voltage porosity testing of the indicated generic types of coating products, at the indicated dry film thicknesses which may contain residual solvents.

Table 1. Determination of the coating film factor (F) from coating type and volume solids content.

Generic Type of Coating Volume Solids %(V/V)	Volume Solids %(V/V) Factor (F)	Factor (F)
Chlorinated rubber, Vinyl	15 to 39	4
Low Build Epoxy, some Tar Epoxy	40 to 59	3
High Build Epoxy, some Tar Epoxy	60 to 79	2
Polyester/Vinyl esters, Solventless Epoxy, Fusion-bonded Epoxy	80 plus	1

Table 2. Determination of the minimum test voltage (V) from dry film thickness (T) and coating material factor (F).

Nominal dry film thickness in microns	Minimum Test Voltage (kV)			
	F=1	F=2	F=3	F=4
150	3.00	1.50	1.00	0.75
250	4.00	2.00	1.30	1.00
400	5.00	2.50	1.60	1.25
600	6.10	3.00	2.00	1.50
800	7.00	3.50	2.30	*
1500	9.70	4.80	*	*
2500	12.50	*	*	*
4000	15.80	*	*	*

Formula 1

$$V = \frac{250 \times \sqrt{T}}{F}$$

- V = minimum test voltage applied in volts
- T = dry film thickness of cured coating in microns
- F = a whole number factor which rates a coating's generic type and residual solvent content (Table 1)

The above minimum test voltages have been derived from Australian Standard AS3894.1-2002; the whole of this Standard should be used. The above voltages relate to the following: the detector should have a direct earth connection to the substrate and a fine wire brush electrode must be connected to the probe.

ALLOW AN ADDITIONAL 200 VOLTS IF THE NEON IN THE PROBE HANDLE IS IN USE.

International Standards
NACE RP0274-04 derived table

Table 3 below is derived from NACE standards and should be used as a guide only.

Table 3. kV Values from
NACE RP0274-98

mm	kiloVolts
0.51	6
0.79	7
1.6	10
2.4	12
3.2	14
4.0	16
4.8	17
13	28
16	31
19	34

The above table should be taken as a GUIDE only. It is recommended that the whole of this standard be used.

ALLOW AN ADDITIONAL 200 VOLTS IF THE NEON IN THE PROBE HANDLE IS IN USE.

6.0 TROUBLESHOOTING

In order to ensure that your Compact Porosity Detector is operating to specification, the Detector handle and lead should be checked prior to use. Use the following procedure:

Unscrew the neon holder from the handle.

Using a multi-meter, complete the circuit and check the resistance at both the handle ❶ and the high voltage plug ❷.

If resistance is outside the 18,000 to 22,000 ohm range, or is open circuit:

- (a) Check ❶ and ❷ for either poor connection or damage;
- (b) Check for break or damage to the HV lead ❸.

Replace/rectify connection and leads and then re-test.

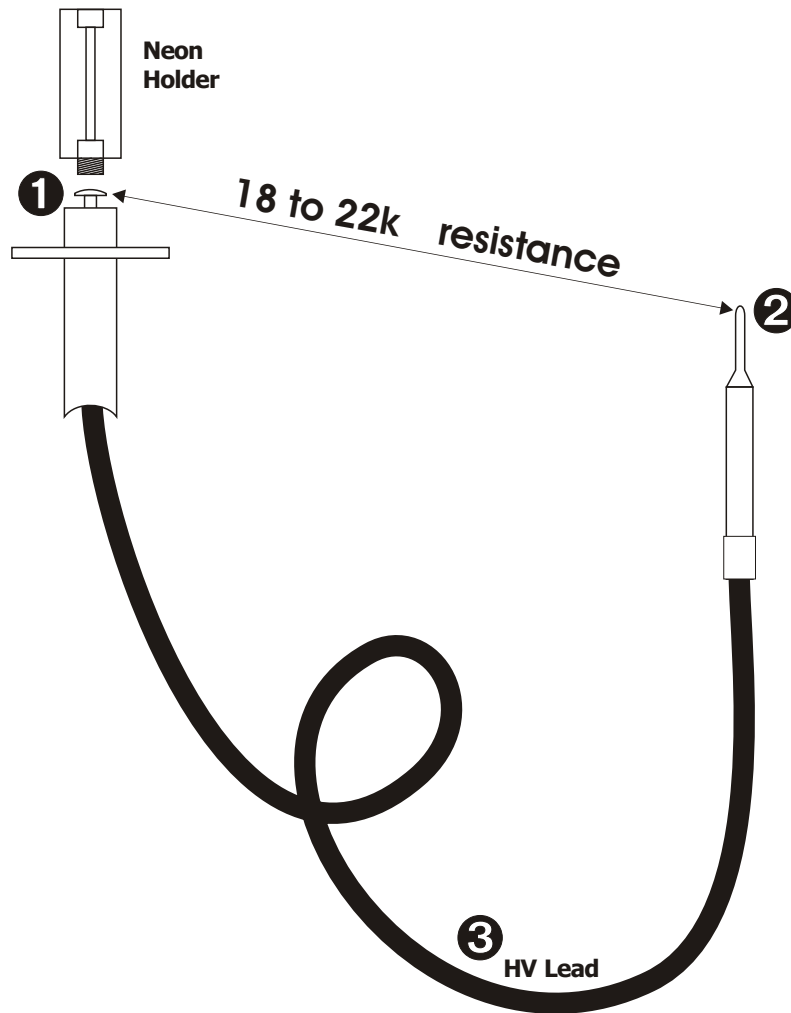

Symptom	Cause	Solution
No Display	Flat battery	Recharge battery
	No Power - fuse not fitted	Fit fuse
Display shows -1	Voltage higher than display capacity	Decrease voltage
Display erratically shows -1	Display drops to -1 when fault found	Normal operation
Display voltage drops during test	Slightly conductive, damp or salty surface	Wash and clean the surface
	Coating may not be fully cured	Allow coating to cure
	Probe surface area too large	Use a smaller probe, or increase voltage
Blackening Display	Poor Earthing	Make positive earth connections
Alarm sounds continuously during test	Slightly conductive, damp or salty surface	Wash and clean the surface
	Coating may not be fully cured	Allow coating to cure.
	Probe moved too fast	Move probe 1 metre every 4 seconds
	Probe surface area too great	Use smaller probe
No alarm on fault	Sensitivity adjusted at too low a setting	Increase sensitivity
	Voltage set too low	Increase voltage
No spark at probe tip	Neon in handle damaged	Replace neon (or use a metal conductor piece)
	Damaged leads	Repair or replace leads
	Poor connections	Clean and reconnect
	Flat Battery	Recharge battery
Probe voltage lower than display voltage	Neon in handle can use up to 200 volts	Turn up voltage control to compensate for neon
	Damaged HV lead	Replace lead
	Poor Earth connection	Check all connections

7.0 OPTIONAL DETECTOR ACCESSORIES

Crest Meters & Certification.



50mm (2in) to 600mm (24in) wide **flat brushes**.
25mm (1in) to 500mm (20in) Spiral wound and Disc **Internal circular pipeline brushes**.
25mm (1in) to 500mm (20in) **External circular pipeline brushes**.

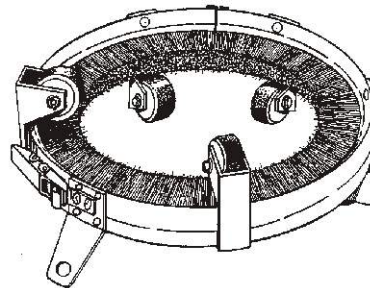
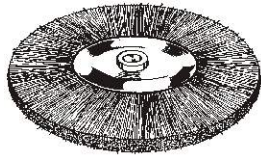
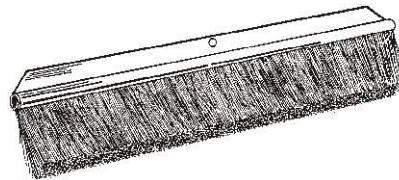
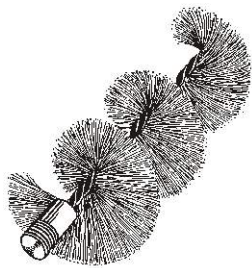

60mm, 125mm, 200mm, 450mm **connectors** for flat or external pipeline brushes.

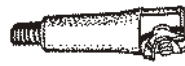

Fan Brushes



450mm covered **probe extensions**.



Spare slip-out **power packs**.

7m **Earth lead** with clamp.

10m trailing Earth lead (1m plastic encased).

Spare **neon light holders** and neons.

50mm (2in) to 1210mm (48in) **Coils** complete with ball bearing ends.

Coil Joiners.

8.0 WARRANTY

Subject to the warranty conditions below this PCWI Instrument is warranted by PCWI International Pty Ltd to be free from defects arising from faulty design, material, or workmanship for a period of 12 months from the date of original purchase by the end user or a maximum period of 15 months to authorised distributor.

Probes and leads are warranted for 3 months. They are consumable items, and subject to wear and deterioration during use. The life of these parts can be much extended by keeping them in a dry clean condition, and storing them in suitable protective containers. During use, avoid “scrubbing” the probe along the surface of the work-piece.

WARRANTY CONDITIONS

During the warranty period listed above PCWI or it's authorized service representative will make good any defects covered by this warranty.

PCWI or it's authorised service representative will decide if there are any defects in design, material or workmanship.

This warranty only applies provided the instrument has been used in accordance with the manufacturers operating handbook recommendations.

This warranty does not cover damage, malfunction or failure resulting from misuse, neglect, abuse or used for a purpose for which it was not designed and no repairs, alterations or modifications have been attempted by other than PCWI on an authorized service.

This warranty applies only to the original user buyer.

This warranty does not cover any service that is needed after an accident, alterations, misuse, fire or floods.

This warranty is the only one given by PCWI and no one has the authority to change, or add to, the obligations and liabilities listed in it.

This warranty does not cover batteries, probe handle brushes (electrodes) and leads which are subject to wear.

During the warranty period PCWI or its authorized service representative will bear the transportation cost of the return of instrument/s repaired under warranty back to the users premises within the country of purchase.

HOW TO MAKE A WARRANTY CLAIM

Defective goods must be returned to PCWI or an authorized service representative at the Purchaser's expense. The goods must be accompanied by the Purchaser's written order describing the defect and authorising PCWI or its authorized service representative to invoice the Purchaser for any charges not covered by the warranty.

The purchasers order must also include the model and serial numbers of the instrument and address of the distributor and date of purchase.

Upon receipt at the service point the instrument will be examined to determine the nature and cause of the defect.

If the defect is covered by the warranty, a repair will be effected at PCWI's or authorized service representative expense. If the defect is not covered by the warranty, PCWI or authorized service representative will quote the Purchaser for a replacement or repair, and will not proceed until written acceptance of the quotation is received.

9.0 SERVICE AND MAINTENANCE

AUTHORISED SERVICE REPRESENTATIVE

To enable speedy "return to service" whether under warranty or otherwise, PCWI have appointed your distributor as a service centre and have provided all relevant information and recommended parts to be carried to assist distributor's technical staff carry out this essential part of the PCWI customer service.

CARE AND MAINTENANCE

This equipment is protected against hostile environments and is designed for prolonged use in the field without any special maintenance, other than routine battery recharging. However, the equipment is not totally sealed and appropriate precautions should be taken. Remember, it is a precision electronic instrument and should be treated as such. There are no internal user controls.

The equipment should only be operated by qualified personnel.

Some organic materials may attack plastic parts and cause early degradation. Contact with such materials should be avoided.

Do not operate damaged equipment.

Where the power supply is derived from internally mounted rechargeable cells and disassembly of the unit is necessary to access those batteries, **this action would void all warranty.**

SERVICE REPAIRS AND MAINTENANCE

Repairs not covered by the warranty or carried out after the warranty period, will be charged at the current hourly or set service rate, plus the cost of materials.

Goods for repair must be sent at the Purchaser's expense, and be accompanied by the Purchaser's written order describing the defect and authorising PCWI to invoice the purchaser for labour, materials and return delivery cost.

No service or repair will be undertaken until a written order is received.

BEFORE YOU CALL FOR SERVICE

Read the section on "troubleshooting" in this handbook and check the symptom, cause and solution before you call for service.

AUTHORISED SERVICE AGENT:



PCWI OFFERS

Strong technical support

In-house development and manufacturing enables us to provide strong technical support and a quick response to enquiries and orders.

Market and product knowledge

We understand technical specifications demanded by industry and recognise customer requirements are specific in relation to testing and measuring instruments.

NATA Accredited Laboratory in Measurement, Science & Technology

PCWI's in-house laboratory can support testing for a range of instruments enabling Certification Traceable to National Standards.

Quality Management System

PCWI's Quality Management System is certified to AS/NZS ISO9001.

Warranties and after sales service

PCWI provides 12 months warranty for its Detectors with detailed operator instruction handbooks and after sales service. An extension of this PCWI service is provided by your local distributor.

