



SPECIAL APPLICATION GAUGES

Model V534 Cannery Gauge

DESCRIPTION

U.S. Gauge V534 Cannery Gauge is used for testing vacuum of packaged products such as canned food or drink. This gauge is easy to use for destructive sampling tests. Force the stainless steel needle through the top of the container while you read the gauge. The rubber gasket prevents air from entering the container during the test. The 1" graduations in Hg are easy to read within the 2" diameter case. Stainless steel needle can be cleaned for multiple uses, but is non-removable. Private labeling is available for OEM applications.

SPECIFICATIONS

- SIZES:** 2"
- RANGES:** Vacuum, 0-30" Hg
- ACCURACY:** 3-2-3%
- BOURDON TUBE:** Beryllium copper
- WINDOW:** Twist-on polycarbonate
- MOVEMENT:** Brass
- DIAL:** Galvalume, white background with black graduations
- POINTER:** Galvalume, black
- CASE:** Brass, chrome-plated
- CONNECTION:** Stainless steel piercing needle

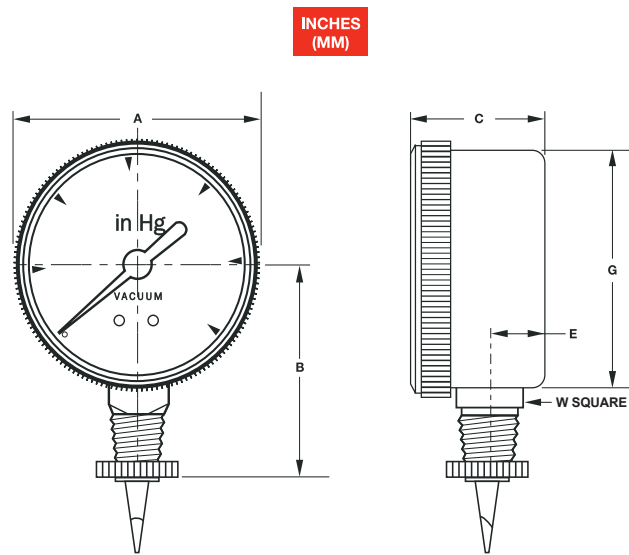

V534 Spec Number Selection Chart and Dimensions										
Spec No.	Model	Unit	Dial Size	Range	A	B	C	E	G	W
050462A	V534	inches mm	2"	0-30" Hg VAC	2.26 57.4	1.95 49.5	1.13 28.7	0.43 10.9	2.05 52.1	0.55 14.0