

The flanged thermowells described on this page are those commonly found in most process applications. These wells are supplied as standard- or heavy-duty with raised-faced flanges. Other types and styles are listed later in this section. Consult factory for wells with different flange sides, lengths, and materials.

FLANGED THERMOWELLS

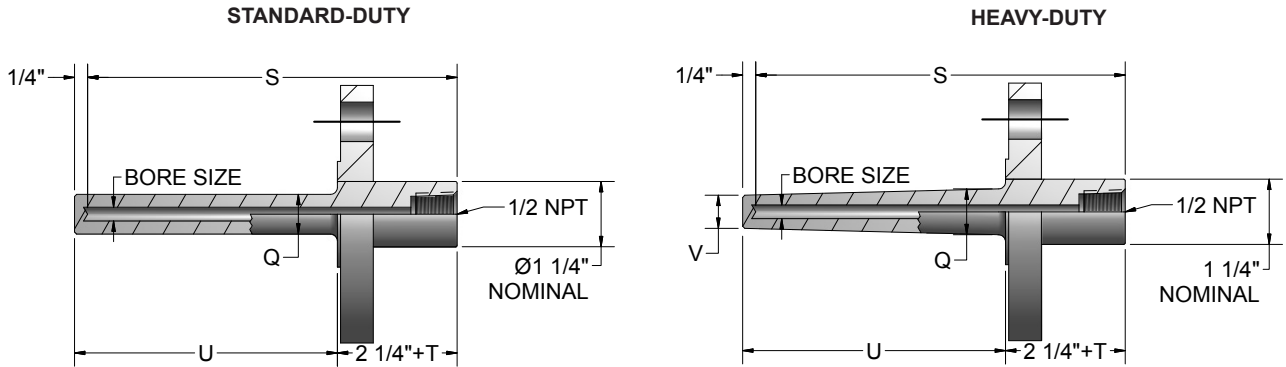

ORDER CODES

Example Order Number:

1-0 1-1 1-2 1-3 1-4 1-5 1-6 1-7 1-8
SF 4 15 R 3 12 08 T2 C8

1-0 Well Type

CODE	DESCRIPTION
SF	Standard-duty flanged
HF	Heavy-duty flanged

1-1 Bore Size

CODE	DESCRIPTION
4	0.260 Bore

1-2 Flange Size

CODE	DESCRIPTION
10	1"
15	1 1/2"
20	2"

1-3 Flange Type

CODE	DESCRIPTION
R	Raised face

1-4 Pressure Rating

CODE	DESCRIPTION
1	150 class
3	300 class

1-8 Well Options

CODE	DESCRIPTION
C8	316 stainless steel well cap and chain
C22	Brass well cap and chain
S	Customer specified part number marked on thermowell (10 digit maximum)

1-7 Optional "T" Lag Dimension

CODE	DESCRIPTION
	Leave blank if no lag is required
T__	Specify "T" dimension in inches

1-6 Well Material

CODE	DESCRIPTION
08	316 Stainless steel
09	304 Stainless steel

1-5 Well Length (inches)

CODE	DESCRIPTION	
	"S" DIMENSION	"U" DIMENSION
06	6	4
09	9	7
12	12	10
15	15	13
18	18	16
24	24	22